



OIL AND GAS PRODUCTION HANDBOOK

An introduction to oil and gas production

Håvard Devold
© 2006 ABB ATPA Oil and Gas

ABB

PREFACE

This handbook is has been compiled to give readers with an interested in the oil and gas production industry an overview of the main processes and equipment. When I started to search for a suitable introduction to be used for new engineers, I discovered that much of this equipment is described in standards, equipment manuals and project documentation. But little material was found to quickly give the reader an overview of the entire upstream area, while still preserving enough detail to let the engineer get an appreciation of the main characteristics and design issues.,

This book is by no means a comprehensive description on the detailed design of any part of this process, and many details have been omitted in the interest of overview. I have included some comments on the control issues, since that is part of my own background. For the same reason, the description will be somewhat biased toward the offshore installations.

The material has been compiled form various online sources as well as ABB and customer documents. I am thankful to my colleagues in the industry for providing valuable input, in particular Erik Solbu of Norsk Hydro for the Njord process and valuable comments. I have included many photos to give the reader an impression what typical facilities or equipment look like. Non-ABB photo source given below picture other pictures and illustrations are ABB.

Edition 1.3 Oslo, June 2006

Håvard Devold

©2006 ABB ATPA Oil and Gas

Except as otherwise indicated, all materials, including but not limited to design, text, graphics, other files, and the selection and arrangement thereof, are the copyright property of ABB, ALL RIGHTS RESERVED. You may electronically copy and print hard-copy of this document only for non-commercial personal use, or non-commercial use within the organization that employs you, provided that the materials are not modified and all copyright or proprietary notices are retained. Use of photos and graphics and references form other sources in no way promotes or endorses these products and services and is for illustration only.

CONTENTS

1	Introduction.....	4
2	Process overview	6
2.1	Facilities	7
2.1.1	Onshore.....	8
2.1.2	Offshore.....	9
2.2	Main Process Sections.....	12
2.2.1	Wellheads	12
2.2.2	Manifolds/gathering.....	12
2.2.3	Separation	13
2.2.4	Gas compression.....	14
2.2.5	Metering, storage and export	15
2.3	Utility systems.....	16
3	Reservoir and Wellheads	17
3.1	Crude oil and Natural gas.....	17
3.1.1	Crude Oil	17
3.1.2	Natural Gas	18
3.1.3	Condensates	19
3.2	The Reservoir	19
3.3	Exploration and Drilling.....	21
3.4	The Well.....	24
3.4.1	Well Casing	25
3.4.2	Completion	26
3.5	Wellhead	27
3.5.1	Subsea wells	29
3.5.2	Injection	30
3.6	Artificial Lift	30
3.6.1	Rod Pumps.....	31
3.6.2	Downhole Pumps.....	31
3.6.3	Gas Lift.....	32
3.6.4	Plunger Lift.....	33
3.7	Well workover, intervention and stimulation.....	33
3.8	Unconventional sources of oil and gas.....	35
3.8.1	Extra Heavy Crude	35
3.8.2	Tar sands.....	36
3.8.3	Oil Shale	36
3.8.4	Coal, Coal Gasification and Liquefaction.....	37
3.8.5	Methane Hydrates	37
3.8.6	Biofuels.....	38
3.8.7	Hydrogen	38
4	The Oil and Gas Process.....	40
4.1	Manifolds and Gathering.....	42

4.1.1	Pipelines, and Risers.....	42
4.1.2	Production, test and injection manifolds.....	42
4.2	Separation.....	43
4.2.1	Test Separators and Well test.....	43
4.2.2	Production separators.....	43
4.2.3	Second stage separator.....	45
4.2.4	Third stage separator.....	45
4.2.5	Coalescer	46
4.2.6	Electrostatic Desalter	46
4.2.7	Water treatment	46
4.3	Gas treatment and Compression.....	48
4.3.1	Heat exchangers.....	48
4.3.2	Scrubbers and reboilers.....	49
4.3.3	Compressor anti surge and performance.....	50
4.3.4	Gas Treatment.....	54
4.4	Oil and Gas Storage, Metering and Export	54
4.4.1	Fiscal Metering	54
4.4.2	Storage	57
4.4.3	Marine Loading	58
4.4.4	Pipeline terminal.....	58
5	Utility systems	59
5.1	Control and Safety Systems	59
5.1.1	Process Control.....	59
5.1.2	Emergency Shutdown and Process Shutdown	62
5.1.3	Control and Safety configuration.....	63
5.1.4	Fire and Gas Systems.....	65
5.1.5	Telemetry / SCADA	66
5.1.6	Condition Monitoring and Maintenance Support	67
5.1.7	Production Information Management Systems (PIMS).....	68
5.1.8	Training Simulators	69
5.2	Power generation and distribution.....	69
5.3	Flare and Atmospheric Ventilation	71
5.4	Instrument air	72
5.5	HVAC	72
5.6	Water Systems.....	73
5.6.1	Potable Water.....	73
5.6.2	Seawater.....	73
5.6.3	Ballast Water	73
5.7	Chemicals and Additives.....	74
5.8	Telecom.....	77
6	Units.....	78
7	Acronyms.....	80
8	References.....	82

1 Introduction

Oil has been used for lighting purposes for many thousand years. In areas where oil is found in shallow reservoirs, seeps of crude oil or gas may naturally develop, and some oil could simply be collected from seepage or tar ponds. Historically, we know of tales of eternal fires where oil and gas seeps would ignite and burn. One example 1000 B.C. is the site where the famous oracle of Delphi would be built, and 500 B.C. Chinese were using natural gas to boil water.

But it was not until 1859 that "Colonel" Edwin Drake drilled the first successful oil well, for the sole purpose of finding oil.

The Drake Well was located in the middle of quiet farm country in north-western Pennsylvania, and began the international search for and industrial use of petroleum.

Photo: Drake Well Museum Collection, Titusville, PA



These wells were shallow by modern standards, often less than 50 meters, but could give quite large production. In the picture from the Tarr Farm, Oil Creek Valley, the Phillips well on the right was flowing initially at 4000 barrels per day in October 1861, and the Woodford well on the left came in at 1500 barrels per day in July,

1862. The oil was collected in the wooden tank in the foreground. Note the many different sized barrels in the background. At this time, barrel size was not yet standardized, which made terms like "Oil is selling at \$5 per barrel" very confusing (today a barrel is 159 liters, see units at the back). But even in those days, overproduction was an issue to be avoided. When the "Empire well" was completed in September 1861, it gave 3,000 barrels per day, flooding the market, and the price of oil plummeted to 10 cents a barrel.

Soon, oil had replaced most other fuels for mobile use. The automobile industry developed at the end of the 19th century, and quickly adopted the fuel. Gasoline engines were essential for designing successful aircraft. Ships driven by oil could move up to twice as fast as their coal fired counterparts, a vital military advantage. Gas was burned off or left in the ground.

Despite attempts at gas transportation as far back as 1821, it was not until after the World War II that welding techniques, pipe rolling, and metallurgical advances allowed for the construction of reliable long distance pipelines, resulting in a natural gas industry boom. At the same time the petrochemical industry with its new plastic materials quickly increased production. Even now gas production is gaining market share as LNG provides an economical way of transporting the gas from even the remotest sites.

With oil prices of 50 dollars per barrel or more, even more difficult to access sources become economically interesting. Such sources include tar sands in Venezuela and Canada as well as oil shales. Synthetic diesel (syndiesel) from natural gas and biological sources (biodiesel, ethanol) have also become commercially viable. These sources may eventually more than triple the potential reserves of hydrocarbon fuels.

2 Process overview

The following figure gives a simplified overview of the typical oil and gas production process

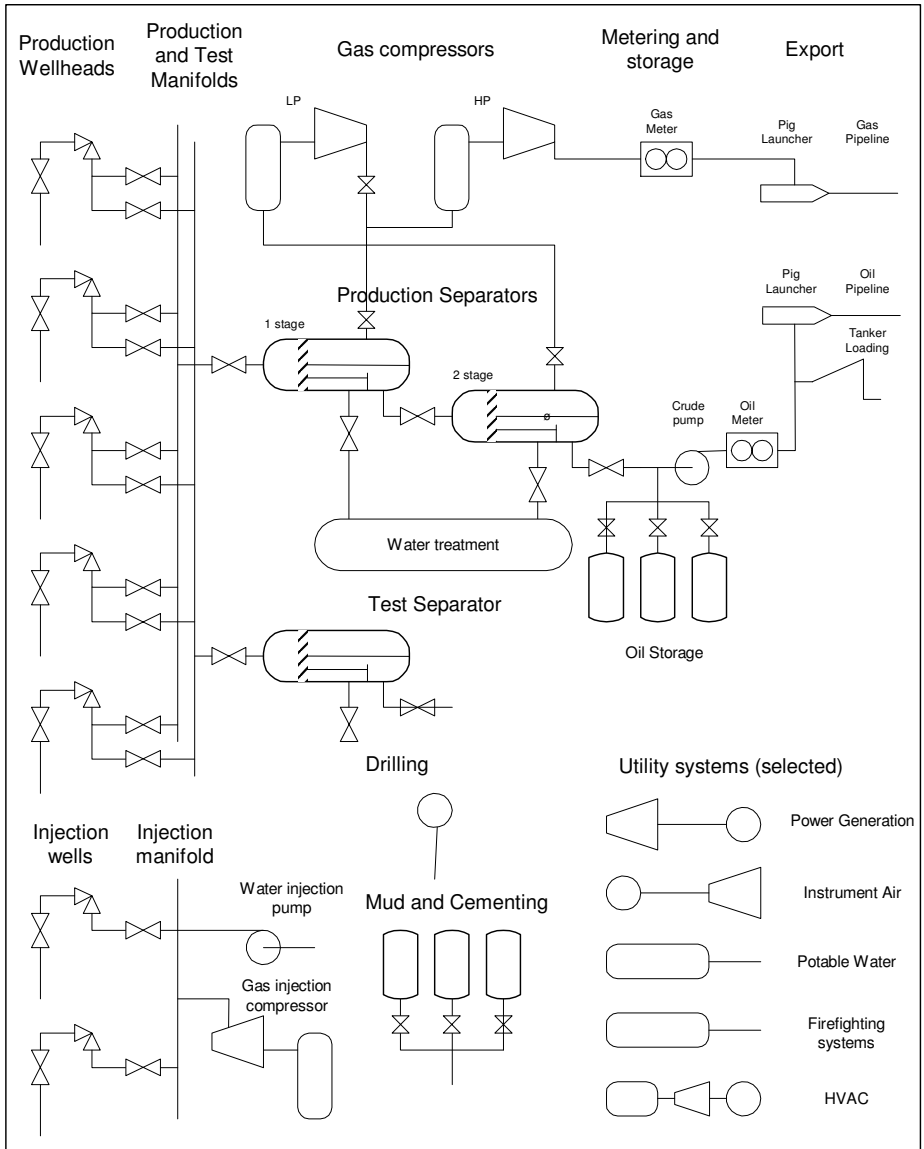

Figure 1 Oil and Gas production overview

Today oil and gas is produced in almost every part of the world, from small 100 barrel a day small private wells, to large bore 4000 barrel a day wells; In shallow 20 meters deep reservoirs to 3000 meter deep wells in more than 2000 meters water depth; In 10.000 dollar onshore wells to 10 billion dollar offshore developments. Despite this range many parts of the process is quite similar in principle.

At the left side, we find the wellheads. They feed into production and test manifolds. In a distributed production system this would be called the gathering system. The remainder of the figure is the actual process, often called the Gas Oil Separation Plant (GOSP). While there are oil or gas only installations, more often the well-stream will consist of a full range of hydrocarbons from gas (methane, butane, propane etc.), condensates (medium density hydro-carbons) to crude oil. With this well flow we will also get a variety of non wanted components such as water, carbon dioxide, salts, sulfur and sand. The purpose of the GOSP is to process the well flow into clean marketable products: oil, natural gas or condensates. Also included are a number of utility systems, not part of the actual process, but providing energy, water, air or some other utility to the plant.

2.1 Facilities

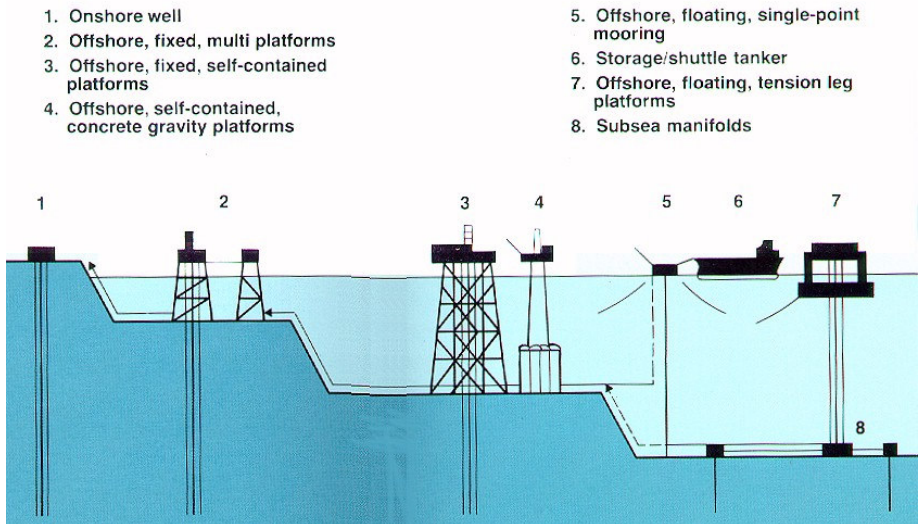

Figure 2 Oil and Gas production facilities

2.1.1 Onshore

Onshore production is economically viable from a few tens of barrels a day upwards. Oil and gas is produced from several million wells world-wide. In particular, a gas gathering network can become very large, with production from hundreds of wells, several hundred kilometers/miles apart, feeding through a gathering network into a processing plant. The picture shows a well equipped with a sucker rod pump (donkey pump) often associated with onshore oil production. However, as we shall see later, there are many other ways of extracting oil from a non-free flowing well



For the smallest reservoirs, oil is simply collected in a holding tank and collected at regular intervals by tanker truck or railcar to be processed at a refinery.

But onshore wells in oil rich areas are also high capacity wells with thousands of barrels per day, connected to a 1.000.000 barrel a day gas oil separation plant (GOSP). Product is sent from the plant by pipeline or tankers. The production may come from many different license owners. Metering and logging of individual well-streams into the gathering network are important tasks...

Recently, very heavy crude, tar sands and oil shales have become economically extractible with higher prices and new technology. Heavy crude may need heating and diluent to be extracted, tar sands have lost their volatile compounds and are strip mined or could be extracted with steam. It must be further processed to



separate bitumen from the sand. These unconventional of reserves may contain more than double the hydrocarbons found in conventional reservoirs. *Photo: Energyprobe.org cp file*

2.1.2 Offshore

Offshore, depending on size and water depth, a whole range of different structures are used. In the last few years, we have seen pure sea bottom installations with multiphase piping to shore and no offshore topside structure at all. Replacing outlying wellhead towers, deviation drilling is used to reach different parts of the reservoir from a few wellhead cluster locations. Some of the common offshore structures are:

Shallow water complex, characterized by a several independent platforms with different parts of the process and utilities linked with gangway bridges. Individual platforms will be described as Wellhead Platform, Riser Platform, Processing Platform, Accommodations Platform and Power Generation Platform. The picture shows the Ekofisk Field Centre by Phillips petroleum. Typically found in water depths up to 100 meters. *Photo: Conoco Phillips*

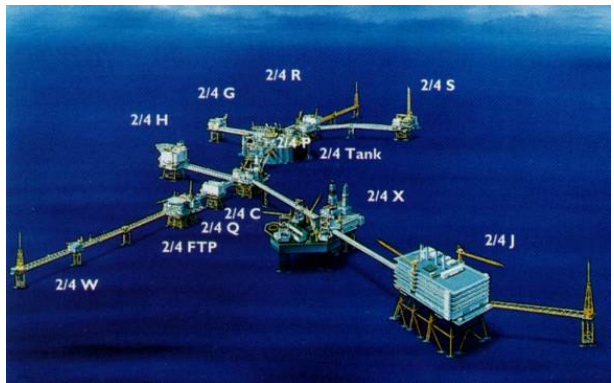

Gravity Base. Enormous concrete fixed structures placed on the bottom, typically with oil storage cells in the “skirt” that rests on the sea bottom. The large deck receives all parts of the process and utilities in large modules. Typical for 80s and 90s large fields in 100 to 500 water depth. The concrete was poured at an at shore location, with enough air in the storage cells to keep the structure floating until tow out and lowering onto the seabed. The picture shows the world’s largest GBS platform, the Troll A during construction. *Photo Statoil ASA*



Compliant towers are much like fixed platforms. They consist of a narrow tower, attached to a foundation on the seafloor and extending up to the platform. This tower is flexible, as opposed to the relatively rigid legs of a fixed platform. This flexibility allows it to operate in much deeper water, as it can 'absorb' much of the pressure exerted on it by the wind and sea. Compliant towers are used between 500 and 1000 meters water depth.

Floating production, where all topside systems are located on a floating structure with dry or subsea wells. Some floaters are:

FPSO: Floating Production, Storage and Offloading. Typically a tanker type hull or barge with wellheads on a turret that the ship can rotate freely around (to point into wind, waves or



current). The turret has wire rope and chain connections to several anchors (position mooring - POSMOR), or it can be dynamically positioned using thrusters (dynamic positioning – DYNPOS). Water depths 200 to 2000 meters. Common with subsea wells. The main process is placed on the deck, while the hull is used for storage and offloading to a shuttle tanker. May also be used with pipeline transport.

A Tension Leg Platform (TLP) consists of a structure held in place by vertical tendons connected to the sea floor by pile-secured templates. The structure is held in a fixed position by tensioned tendons, which provide for use of the TLP in a broad water depth range up to about 2000m. Limited vertical motion. The tendons are constructed as hollow high tensile strength steel pipes that carry the spare buoyancy of the structure and ensure limited vertical motion. A variant is Seastar platforms which are

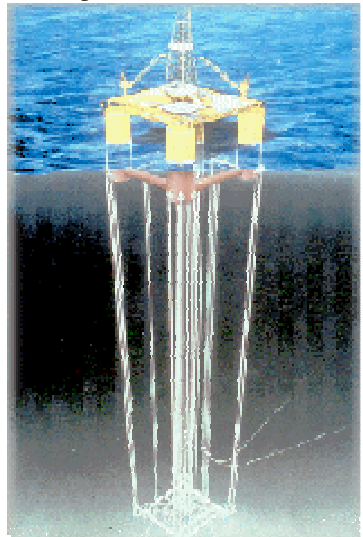

miniature floating tension leg platforms, much like the semi submersible type, with tensioned tendons.

SPAR: The SPAR consists of a single tall floating cylinder hull, supporting a fixed deck. The cylinder however does not extend all the way to the seafloor, but instead is tethered to the bottom by a series of cables and lines. The large cylinder serves to stabilize the platform in the water, and allows for movement to absorb the force of potential hurricanes. Spars can be quite large and are used for water depths from 300 and up to 3000 meters. SPAR is not an acronym, but refers to its likeness with a ship's spar. Spars can support dry completion wells, but is more often used with subsea wells.



Subsea production systems are wells located on the sea floor, as opposed to at the surface. Like in a floating production system, the petroleum is extracted at the seafloor, and then can be 'tied-back' to an already existing production platform or even an onshore facility, limited by horizontal distance or "offset". The well is drilled by a moveable rig and the extracted oil and natural gas is transported by undersea pipeline and riser to a processing facility. This allows one strategically placed production platform to service many wells over a reasonably large area. Subsea systems are typically in use at depths of 7,000 feet or more, and do not have the ability to drill, only to extract and transport. Drilling and completion is performed from a surface rig. Horizontal offsets up to 250 kilometers, 150 miles are currently possible. *Photo:Norsk Hydro ASA*

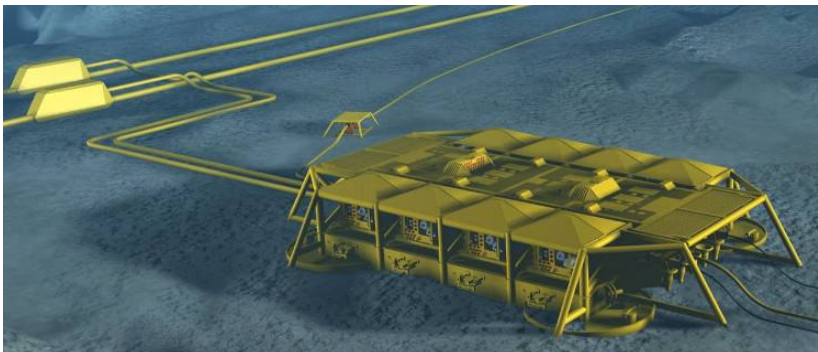

2.2 Main Process Sections

We will go through each section in detail in the following chapters. The summary below is an introductory short overview of each section

2.2.1 Wellheads

The wellhead sits on top of the actual oil or gas well leading down to the reservoir. A wellhead may also be an injection well, used to inject water or gas back into the reservoir to maintain pressure and levels to maximize production.

Once a natural gas or oil well is drilled, and it has been verified that commercially viable quantities of natural gas are present for extraction, the well must be 'completed' to allow for the flow of petroleum or natural gas out of the formation and up to the surface. This process includes strengthening the well hole with casing, evaluating the pressure and temperature of the formation, and then installing the proper equipment to ensure an efficient flow of natural gas out of the well. The well flow is controlled with a choke.



We differentiate between dry completion with is either onshore or on the deck of an offshore structure, and Subsea completions below the surface. The wellhead structure, often called a Christmas tree, must allow for a number of operations relating to production and well workover. Well workover refers to various technologies for maintaining the well and improving its production capacity.

2.2.2 Manifolds/gathering

Onshore, the individual well streams are brought into the main production facilities over a network of gathering pipelines and manifold systems. The purpose of these is to allow set up of production “well sets” so that for a given production level, the best

reservoir utilization, well flow composition (gas, oil, waster) etc. can be selected from the available wells.

For gas gathering systems, it is common to meter the individual gathering lines into the manifold as shown on the illustration. For multiphase (combination of gas, oil and water) flows, the high cost of multiphase flow meters often lead to the use of software flow rate estimators that use well test data to calculate the actual flow.

Offshore, the dry completion wells on the main field centre feed directly into production manifolds, while outlying wellhead towers and subsea installations feed via multiphase pipelines back to the production risers. Risers are the system that allow a pipeline to “rise” up to the topside structure. For floating or structures, this involves a way to take up weight and movement. For heavy crude and in arctic areas, diluents and heating may be needed to reduce viscosity and allow flow.



2.2.3 Separation

Some wells have pure gas production which can be taken directly to gas treatment and/or compression. More often, the well gives a combination of gas, oil and water and various contaminants which must be separated and processed. The production separators come in many forms and designs, with the classical variant being the gravity separator.



In gravity separation the well flow is fed into a horizontal vessel. The retention period is typically 5 minutes, allowing the gas to bubble out, water to settle at the bottom and oil to be taken out in the middle. The pressure is often reduced in several stages (high pressure separator, low pressure separator etc.) to allow controlled separation of volatile components. A sudden pressure reduction might allow flash vaporization leading to instabilities and safety hazards. *Photo: JL Bryan Oilfield Equipment*

2.2.4 Gas compression

Gas from a pure natural gas wellhead might have sufficient pressure to feed directly into a pipeline transport system. Gas from separators has generally lost so much pressure that it must be recompressed to be transported. Turbine compressors gain their energy by using up a small proportion of the natural gas that they compress. The turbine itself serves to operate a centrifugal compressor, which contains a type of fan that compresses and pumps the natural gas through the pipeline. Some compressor stations are operated by using an electric motor to turn the same type of centrifugal compressor. This type of compression does not require the use of any of the natural gas from the pipe; however it does require a reliable source of electricity nearby. The compression includes a large section of associated equipment such as scrubbers (removing liquid droplets) and heat exchangers, lube oil treatment etc.



Whatever the source of the natural gas, once separated from crude oil (if present) it commonly exists in mixtures with other hydrocarbons; principally ethane, propane, butane, and pentanes. In addition, raw natural gas contains water vapor, hydrogen sulfide (H₂S), carbon dioxide, helium, nitrogen, and other compounds.

Natural gas processing consists of separating all of the various hydrocarbons and fluids from the pure natural gas, to produce what is known as 'pipeline quality' dry natural gas. Major transportation pipelines usually impose restrictions on the make-

up of the natural gas that is allowed into the pipeline. That means that before the natural gas can be transported it must be purified.

Associated hydrocarbons, known as 'natural gas liquids' (NGL) are used as raw materials for oil refineries or petrochemical plants, and as sources of energy.

2.2.5 Metering, storage and export

Most plants do not allow local gas storage, but oil is often stored before loading on a vessel, such as a shuttle tanker taking the oil to a larger tanker terminal, or direct to crude carrier. Offshore production facilities without a direct pipeline connection generally rely on crude storage in the base or hull, to allow a shuttle tanker to offload about once a week. A larger production complex generally has an associated tank farm terminal allowing the storage of different grades of crude to take up changes in demand, delays in transport etc.

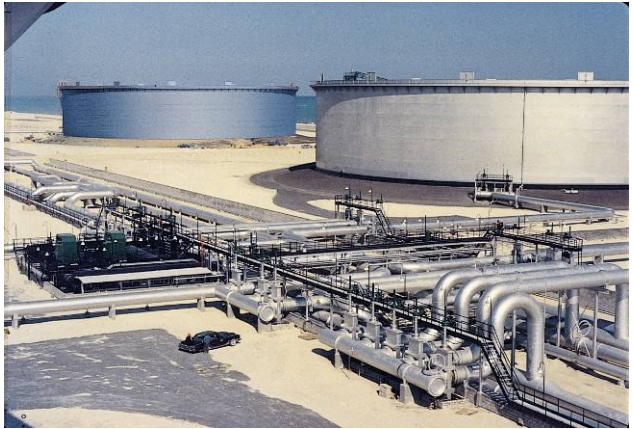

Metering stations allow operators to monitor and manage the natural gas and oil exported from the production installation. These metering stations employ specialized meters to measure the natural gas or oil as it flows through the pipeline, without impeding its movement.

This metered volume represents a transfer of ownership from a producer to a customer



(or another division within the company) and is therefore called Custody Transfer Metering. It forms the basis for invoicing sold product and also for production taxes and revenue sharing between partners and accuracy requirements are often set by governmental authorities.

Typically the metering installation consists of a number of meter runs so that one meter will not have to handle the full capacity range, and associated prover loops so that the meter accuracy can be tested and calibrated at regular intervals.

Pipelines can measure anywhere from 6 to 48 inches in diameter. In order to ensure the efficient and safe operation of the pipelines, operators routinely inspect their pipelines for corrosion and defects. This is done through the use of sophisticated pieces of equipment known as pigs. Pigs are intelligent



robotic devices that are propelled down pipelines to evaluate the interior of the pipe. Pigs can test pipe thickness, and roundness, check for signs of corrosion, detect minute leaks, and any other defect along the interior of the pipeline that may either impede the flow of gas, or pose a potential safety risk for the operation of the pipeline. Sending a pig down a pipeline is fittingly known as 'pigging' the pipeline. The export facility must contain equipment to safely insert and retrieve pigs from the pipeline as well as depressurization, referred to as pig launchers and pig receivers

Loading on tankers involve loading systems, ranging from tanker jetties to sophisticated single point mooring and loading systems that allow the tanker to dock and load product even in bad weather.

2.3 Utility systems

Utility systems are systems which does not handle the hydrocarbon process flow, but provides some utility to the main process safety or residents. Depending on the location of the installation, many such functions may be available from nearby infrastructure (e.g. electricity). But many remote installations must be fully self sustainable and thus must generate their own power, water etc.

3 Reservoir and Wellheads

There are three main types of conventional wells. The most common well is an oil well with associated gas. Natural gas wells are wells drilled specifically for natural gas, and contain little or no oil. Condensate wells are wells that contain natural gas, as well as a liquid condensate. This condensate is a liquid hydrocarbon mixture that is often separated from the natural gas either at the wellhead, or during the processing of the natural gas. Depending on the type of well that is being drilled, completion may differ slightly. It is important to remember that natural gas, being lighter than air, will naturally rise to the surface of a well. Because of this, in many natural gas and condensate wells, lifting equipment and well treatment are not necessary, while for oil wells many types of artificial lift might be installed, particularly as the reservoir pressure declines during years of production.

3.1 *Crude oil and Natural gas*

3.1.1 Crude Oil

Crude Oil is a complex mixture consisting of up to 200 or more different organic compounds, mostly hydrocarbons. Different crude contain different combinations and concentrations of these various compounds. The API (American petroleum institute) gravity of a particular crude is merely a measure of its specific gravity, or density. The higher the API number, expressed as degrees API, the less dense (lighter, thinner) the crude. Conversely, the lower the degrees API, the more dense (heavier, thicker) the crude. Crude from different fields and from different formations within a field can be similar in composition or be significantly different.

In addition to API grade and hydrocarbons, crude is characterized for other non-wanted elements like sulfur which is regulated and needs to be removed.

Crude oil API gravities typically range from 7 to 52 corresponding to about 970 kg/m³ to 750 kg/m³, but most fall in the 20 to 45 API gravity range. Although light crude (i.e., 40-45 degree API) is good, lighter crude (i.e., 46 degree API and above) is not necessarily better for a typical refinery. Looking at the chemical composition of crude, as the crude gets lighter than 40-45 degrees API, it contains shorter molecules, or less of the desired compounds useful as high octane gasoline and diesel fuel, the production of which most refiners try to maximize. Likewise, as crude gets heavier than 35 degrees API, it contains longer and bigger molecules that are not useful as high octane gasoline and diesel fuel without further processing.

For crude that have undergone detailed physical and chemical property analysis, the API gravity can be used as a rough index of the quality of the crude of similar composition as they naturally occur (that is, without adulteration, mixing, blending, etc.). When crude of different type and quality are mixed, or when different petroleum components are mixed, API gravity cannot be used meaningfully for anything other than a measure of the density of the fluid.

For example, consider a barrel of tar that is dissolved in 3 barrels of naphtha (lighter fluid) to produce 4 barrels of a 40 degree API mixture. When this 4-barrel mixture is fed to a distillation column at the inlet to a refinery, one barrel of tar plus 3 barrels of lighter fluid is all that will come out of the still. On the other hand, 4 barrels of a naturally occurring 40 degree API South Louisiana Sweet crude when fed to the distillation column at the refinery could come out of the still as 1.4 barrels of gasoline and naphtha, 0.6 barrels of kerosene (jet fuel), 0.7 barrels of diesel fuel, 0.5 barrels of heavy distillate, 0.3 barrels of lubricating stock, and 0.5 barrels of residuum (tar).

The figure to the right illustrates weight percent distributions of three different hypothetical petroleum stocks that could be fed to a refinery with catalytic cracking capacity. The chemical composition is generalized by the carbon number which is the number of carbon atoms in each molecule. The medium blend is desired because it

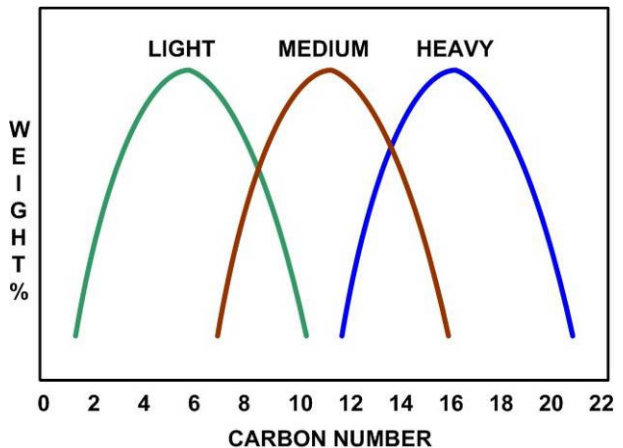

has the composition that will yield the highest output of high octane gasoline and diesel fuel in the cracking refinery. Though the heavy stock and the light stock could be mixed to produce a blend with the same API gravity as the medium stock, the composition of the blend would be far different from the medium stock, as the figure indicates. Heavy crude can be processed in a refinery by cracking and reforming that reduces the carbon number to increase the high value fuel yield.

3.1.2 Natural Gas

The natural gas used by consumers is composed almost entirely of methane. However, natural gas found at the wellhead, although still composed primarily of

methane, is by no means as pure. Raw natural gas comes from three types of wells: oil wells, gas wells, and condensate wells. Natural gas that comes from oil wells is typically termed 'associated gas'. This gas can exist separate from oil in the formation (free gas), or dissolved in the crude oil (dissolved gas). Natural gas from gas and condensate wells, in which there is little or no crude oil, is termed 'non associated gas'. Gas wells typically produce raw natural gas by itself, while condensate wells produce free natural gas along with a semi-liquid hydrocarbon condensate. Whatever the source of the natural gas, once separated from crude oil (if present) it commonly exists in mixtures with other hydrocarbons; principally ethane, propane, butane, and pentanes. In addition, raw natural gas contains water vapor, hydrogen sulfide (H₂S), carbon dioxide, helium, nitrogen, and other compounds.

Natural gas processing consists of separating all of the various hydrocarbons and fluids from the pure natural gas, to produce what is known as 'pipeline quality' dry natural gas. Major transportation pipelines usually impose restrictions on the make-up of the natural gas that is allowed into the pipeline and measure energy content in kJ/kg (also called calorific value or wobbe index).

3.1.3 Condensates

While the ethane, propane, butane, and pentanes must be removed from natural gas, this does not mean that they are all 'waste products'. In fact, associated hydrocarbons, known as 'natural gas liquids' (NGL) can be very valuable by-products of natural gas processing. NGL include ethane, propane, butane, iso-butane, and natural gasoline. These NGLs are sold separately and have a variety of different uses; raw materials for oil refineries or petrochemical plants, as sources of energy, and for enhancing oil recovery in oil wells,. Condensates are also useful as diluent for heavy crude, see below.

3.2 The Reservoir

The oil and gas bearing structure is typically a porous rock such as sandstone or washed out limestone. The sand might have been laid down as desert sand dunes or seafloor. Oil and gas deposits form as organic material (tiny plants and animals) deposited in earlier geological periods, typically

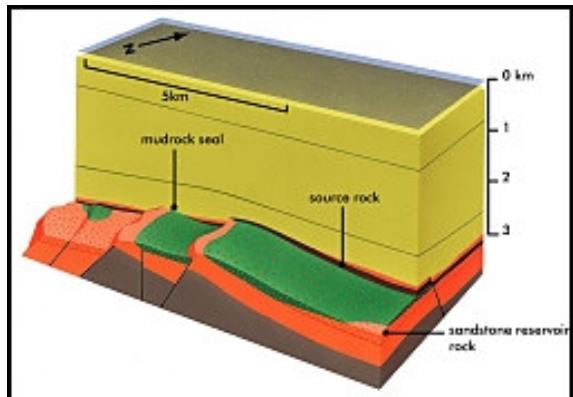

100 to 200 million years ago, under, over or with the sand or silt, is transformed by high temperature and pressure into hydrocarbons.

For an oil reservoir to form, porous rock needs to be covered by a non porous layer such as salt, shale, chalk or mud rock that can prevent the hydrocarbons from leaking out of the structure. As rock structures become folded and uplifted as a result of tectonic movements, the hydrocarbons migrates out of the deposits and upward in porous rocks and collects in crests under the non permeable rock, with gas at the top, then oil and fossil water at the bottom. . III: UKOOA

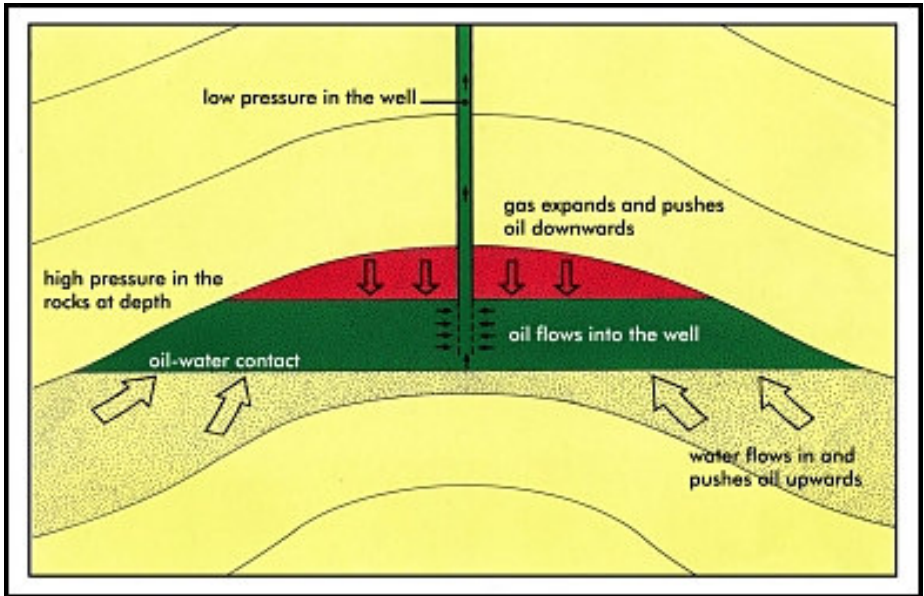

This process goes on continuously, even today. However, an oil reservoir matures in the sense that a too young formation may not yet have allowed the hydrocarbons to form and collect. A young reservoir (e.g. 60 million years) often has heavy crude, less than 20 API. In some areas, strong uplift and erosion and cracking of rock above have allowed the hydrocarbons to leak out, leaving heavy oil reservoirs or tar pools. Some of the world's largest oil deposits are tar sands where the volatile compounds have evaporated from shallow sandy formations leaving huge volumes of bitumen soaked sands. These are often exposed at the surface, and could be strip mined, but must be separated from the sand with hot water, steam and diluents and further processed with cracking and reforming in a refinery) to improve its fuel yield.

The oil and gas is pressurized in the pores of the porous formation rock.

Ill: UKOOA When a well is drilled into the reservoir structure, the hydrostatic formation pressure drives the hydrocarbons out of the rock and up into the well. When the well flows, gas, oil and water is extracted, and the levels will shift as the reservoir is depleted. The challenge is to plan the drilling so that the reservoir utilization can be maximized.

Seismic data and advanced visualization 3D models are used to plan the extraction. Still the average recovery rate is 40%, leaving 60% of the hydrocarbons trapped in the reservoir. The best reservoirs with advanced Enhanced Oil Recovery (EOR) allow up to 70%. Reservoirs can be quite complex, with many folds and several layers of hydrocarbon bearing rock above each other (in some areas more than 10). Modern wells are drilled with large horizontal offsets to reach different parts of the structure and with multiple completions so that one well can produce from several locations. *Ill: UKOOA*

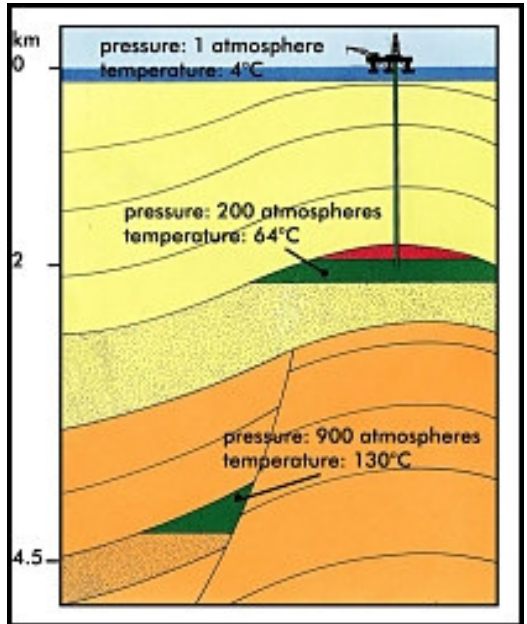

3.3 Exploration and Drilling

When 3D seismic has been completed, it is time to drill the well. Normally dedicated drilling rigs either on mobile onshore units or offshore floating rigs are used. Larger production platforms may also have their own production drilling equipment.

The main components of the drilling rig are the Derrick, Floor, Drawworks, Drive and Mud Handling. The control and power

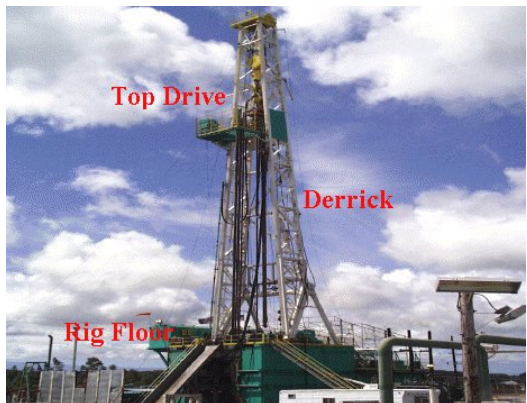

can be hydraulic or electric.

Earlier pictures of Drillers and Roughnecks working with rotary tables (bottom drives) are now replaced with top drive and semi automated pipe handling on larger installations. The hydraulic or electric top drive hangs from the derrick crown and gives pressure and rotational torque to the drill string. The whole assembly is controlled by the drawworks. *Photo: Puna Geothermal Venture*

The Drill String is assembled from pipe segments about 30 meters (100 feet) long normally with conical inside threads at one end and outside at the other. As each 30 meter segment is drilled, the drive is disconnected and a new pipe segment inserted in the string. A cone bit is used to dig into the rock. Different cones are used for different types of rock and at different stages of the well. The picture shows roller cones with inserts (on the left); other bits are PDC (polycrystalline diamond compact, on the right) and Diamond Impregnated. *Photo: Kingdream PLC*

As the well is sunk into the ground, the weight of the drill string increases and might reach 500 metric tons or more for a 3000 meter deep well. The drawwork and top drive must be precisely controlled not to overload and break the drill string or the cone. Typical values are 50kN force on the bit and a torque of 1-1.5 kNm at 40-80 RPM for an 8 inch cone. ROP (Rate of Penetration) is very dependant on depth and could be as much as 20 meters per hour for shallow sandstone and dolomite (chalk) and as low as 1 m/hour on deep shale rock and granite.

Directional drilling is intentional deviation of a well bore from the vertical. It is often necessary to drill

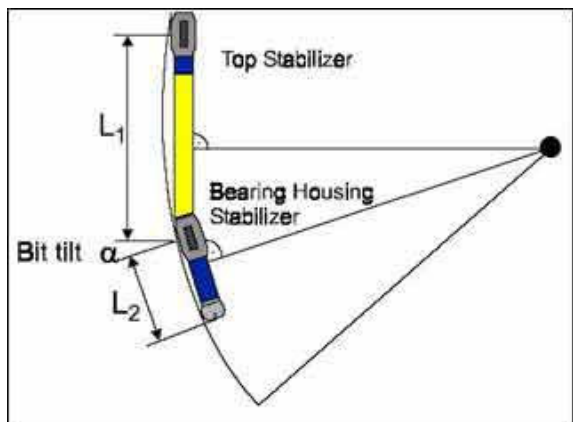

at an angle from the vertical to reach different parts of the formation. Controlled directional drilling makes it possible to reach subsurface areas laterally remote from the point where the bit enters the earth. It often involves the use of a drill motor driven by mud pressure mounted directly on the cone (Mud Motor, Turbo Drill, and Dyna-Drill), whipstocks: a steel casing that will bend between the drill pipe and cone, or other deflecting rods. Also used for horizontal wells and multiple completions, where one well may split into several bores. A well which has sections more than 80 degrees from the vertical is called a horizontal well. Modern wells are drilled with large horizontal offsets to reach different parts of the structure and achieve higher production. The world record is more than 15 kilometers. Multiple completions allows production from several locations.

Wells can be any depth from almost at the surface to a depth of more than 6000 meters. The oil and gas typically formed at 3000-4000 meters depth, but the overlying rock can since have eroded away. The pressure and temperature generally increases with increasing depth, so that deep wells can have more than 200 deg C temperature and 90 MPa pressure (900 times atmospheric pressure), equivalent to the hydrostatic pressure set by the distance to the surface. The weight of the oil in the production string reduces the wellhead pressure. Crude oil has a specific weight of 790 to 970 kg per cubic meter. For a 3000 meter deep well with 30 MPa downhole pressure and normal crude oil at 850 kg/m³, the wellhead static pressure would only be around 4,5 MPa. During production the pressure would go down further due resistance to flow in the reservoir and well.

The mud enters through the drill pipe, through the cone and rises in the uncompleted well. The Mud serves several purposes:

- Bring rock shales (fragments of rock) up to the surface
- Clean and Cool the cone
- Lubricate the drill pipe string and Cone
- Fibrous particles attach to the well surface to bind solids
- Mud weight should balance the downhole pressure to avoid leakage of gas and oil. Often, the well will drill through smaller pockets of hydrocarbons which may cause “a blow out” if the mud weight cannot balance the pressure. The same might happen when drilling into the main reservoir.

To prevent an uncontrolled blow out, a subsurface safety valve is often installed. This valve has enough closing force to seal the well and cut the drill string in an uncontrollable blow-out situation. However unless casing is already also in place, hydrocarbons may also leave through other cracks in the in the well and rise to the surface through porous or cracked rock. In addition to fire and pollution hazards, dissolved gas in seawater rising under a floating structure significantly reduces buoyancy.

The mud mix is a specialist brew designed to match the desired flow viscosity, lubrication properties and specific gravity. Mud is a common name used for all kinds of fluids used in drilling completion and workover. It can be Oil Base, Water Base or Synthetic and consists of powdered clays such as bentonite, Oil, Water and various



additives and chemicals such as caustic soda, barite (sulphurous mineral), lignite (brown coal), polymers and emulsifiers. *Photo: OSHA.gov*

A special high density mud called Kill Fluid is used to shut down a well for workover.

Mud is recirculated. The coarse rock shales are separated in a shale shaker, the mud could then pass through finer filters and recalibrated with new additives before returning to the mud holding tanks

3.4 The Well

When the well has been drilled, it must be completed. Completing a well consists of a number of steps; installing the well casing, completing the well, installing the wellhead, and installing lifting equipment or treating the formation should that be required.

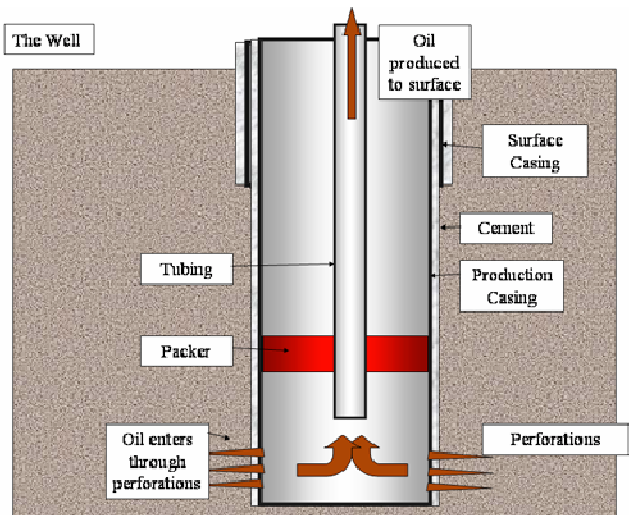

3.4.1 Well Casing

Installing well casing is an important part of the drilling and completion process. Well casing consists of a series of metal tubes installed in the freshly drilled hole. Casing serves to strengthen the sides of the well hole, ensure that no oil or natural gas seeps out of the well hole as it is brought to the surface, and to keep other fluids or gases from seeping into the formation through the well. A good deal of planning is necessary to ensure that the proper casing for each well is installed. Types of casing used depend on the subsurface characteristics of the well, including the diameter of the well (which is dependent on the size of the drill bit used) and the pressures and temperatures experienced throughout the well. In most wells, the diameter of the well hole decreases the deeper it is drilled, leading to a type of conical shape that must be taken into account when installing casing. The casing is normally cemented in place. *Ill: wikipedia.org*

There are five different types of well casing. They include:

- Conductor casing, which is usually no more than 20 to 50 feet long, is installed before main drilling to prevent the top of the well from caving in and to help in the process of circulating the drilling fluid up from the bottom of the well.
- Surface casing is the next type of casing to be installed. It can be anywhere from 100 to 400 meters long, and is smaller in diameter than the conductor casing and fits inside the conductor casing. The primary purpose of surface casing is to protect fresh water deposits near the surface of the well from being contaminated by leaking hydrocarbons or salt water from deeper underground. It also serves as a conduit for drilling mud returning to the surface, and helps protect the drill hole from being damaged during drilling.
- Intermediate casing is usually the longest section of casing found in a well. The primary purpose of intermediate casing is to minimize the hazards that come along with subsurface formations that may affect the well. These include abnormal underground pressure zones, underground shales, and formations that might otherwise contaminate the well, such as underground salt-water deposits. Liner strings are sometimes used instead of intermediate casing. Liner strings are usually just attached to the previous casing with 'hangers', instead of being cemented into place and is thus less permanent
- Production casing, alternatively called the 'oil string' or 'long string', is installed last and is the deepest section of casing in a well. This is the casing that provides a conduit from the surface of the well to the petroleum producing formation. The size of the production casing depends on a number of considerations, including the lifting equipment to be used, the

number of completions required, and the possibility of deepening the well at a later time. For example, if it is expected that the well will be deepened at a later date, then the production casing must be wide enough to allow the passage of a drill bit later on. It is also instrumental in preventing blowouts, allowing the formation to be 'sealed' from the top should dangerous pressure levels be reached.

Once the casing is installed, **tubing** is inserted inside the casing, from the opening well at the top, to the formation at the bottom. The hydrocarbons that are extracted run up this tubing to the surface. The production casing is typically 5 to 28 cm (2 -11 in) with most production wells being 6 in or more. Production depends on reservoir, bore, pressure etc. and could be less than 100 barrels a day to several thousand barrels per day. (5000 bpd is about 555 liters/minute). A **packer** is used between casing and tubing at the bottom of the well.

3.4.2 Completion

Well completion commonly refers to the process of finishing a well so that it is ready to produce oil or natural gas. In essence, completion consists of deciding on the characteristics of the intake portion of the well in the targeted hydrocarbon formation. There are a number of types of completions, including:

- Open hole completions are the most basic type and are only used in very competent formations, which are unlikely to cave in. An open hole completion consists of simply running the casing directly down into the formation, leaving the end of the piping open, without any other protective filter.
- Conventional perforated completions consist of production casing being run through the formation. The sides of this casing are perforated, with tiny holes along the sides facing the formation, which allows for the flow of hydrocarbons into the well hole, but still provides a suitable amount of support and protection for the well hole. In the past, 'bullet perforators' were used. These were essentially small guns lowered into the well that sent off small bullets to penetrate the casing and cement. Today, 'jet perforating' is preferred. This consists of small, electrically ignited charges that are lowered into the well. When ignited, these charges poke tiny holes through to the formation, in the same manner as bullet perforating.
- Sand exclusion completions are designed for production in an area that contains a large amount of loose sand. These completions are designed to allow for the flow of natural gas and oil into the well, but at the same time prevent sand from entering the well. The most common method of keeping

sand out of the well hole are screening, or filtering systems. Both of these types of sand barriers can be used in open hole and perforated completions.

- Permanent completions are those in which the completion, and wellhead, are assembled and installed only once. Installing the casing, cementing, perforating, and other completion work is done with small diameter tools to ensure the permanent nature of the completion. Completing a well in this manner can lead to significant cost savings compared to other types
- Multiple zone completion is the practice of completing a well such that hydrocarbons from two or more formations may be produced simultaneously, without mixing with each other. For example, a well may be drilled that passes through a number of formations on its way deeper underground, or alternately, it may be efficient in a horizontal well to add multiple completions to drain the formation most effectively. When it is necessary to separate different completions, hard rubber 'packing' instruments are used to maintain separation.
- Drainhole completions are a form of horizontal or slant drilling. This type of completion consists of drilling out horizontally into the formation from a vertical well, essentially providing a 'drain' for the hydrocarbons to run down into the well. These completions are more commonly associated with oil wells than with natural gas wells.

3.5 Wellhead

Wellheads can be Dry or Subsea completion.

Dry Completion means that the well is onshore on the topside structure on an offshore installation. Subsea wellheads are located under water on a special sea bed template.

The wellhead consists of the pieces of equipment mounted at the opening of the well to regulate and monitor the extraction of hydrocarbons from the underground formation. It also prevents leaking of oil or natural gas out of the well, and prevents blowouts due to high pressure formations. Formations that are under high pressure typically require wellheads that can withstand a great deal of upward pressure from the escaping gases and liquids. These wellheads must be able to withstand pressures of up to 140 MPa (1400 Bar). The wellhead consists of three



components: the casing head, the tubing head, and the 'Christmas tree' *Photo: Vetco international*

A typical Christmas tree composed of a master gate valve, a pressure gauge, a wing valve, a swab valve and a choke is shown here. The Christmas tree may also have a number of check valves. The functions of these devices are explained in the following paragraphs. *Ill: Vetco international*

At the bottom we find the **Casing Head** and casing Hangers. The casing will be screwed, bolted or welded to the hanger. Several valves and plugs will normally be fitted to give access to the casing. This will permit the casing to be opened, closed, bled down, and, in some cases, allow the flowing well to be produced through the casing as well as the tubing. The valve can be used to determine leaks in casing, tubing or the packer, and will also be used for lift gas injection into the casing.

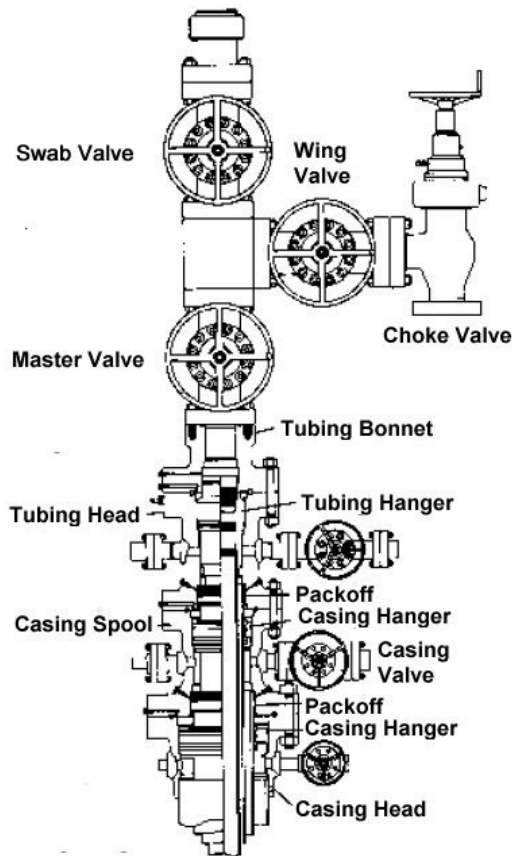

The tubing hanger (also called donut) is used to position the tubing correctly in the well. Sealing also allows Christmas tree removal with pressure in the casing.

Master gate valve. The master gate valve is a high quality valve. It will provide full opening, which means that it opens to the same inside diameter as the tubing so that specialized tools may be run through it. It must be capable of holding the full pressure of the well safely for all anticipated purposes. This valve is usually left fully open and is not used to control flow.

The pressure gauge. The minimum instrumentation is a pressure gauge placed above the master gate valve before the wing valve. In addition other instruments such as temperature will normally be fitted.

The wing valve. The wing valve can be a gate valve, or ball valve. When shutting in the well, the wing gate or valve is normally used so that the tubing pressure can be easily read.

The swab valve. The swab valve is used to gain access to the well for wireline operations, intervention and other workover procedures (see below), on top of it is a tree adapter and cap that will mate with various equipment.

The variable flow choke valve. The variable flow choke valve is typically a large needle valve. Its calibrated opening is adjustable in 1/64 inch increments (called beans). High-quality steel is used in order to withstand the high-speed flow of abrasive materials that pass through the choke, usually for many years, with little damage except to the dart or seat. If a variable choke is not required, a less expensive positive choke is normally installed on smaller wells. This has a built in restriction that limits flow when the wing valve is fully open.

This is a **vertical tree**. Christmas trees can also be **horizontal**, where the master, wing and choke is on a horizontal axis. This reduces the height and may allow easier intervention. Horizontal trees are especially used on subsea wells.

3.5.1 Subsea wells

Subsea wells are essentially the same as dry completion wells. However, mechanically they are placed in a Subsea structure (template) that allows the wells to be drilled and serviced remotely from the surface, and protects remotely from damage e.g. from trawlers. The wellhead is placed in a slot in the template where it mates to the outgoing pipeline as well as hydraulic and electric control signals.

Ill: Statoil

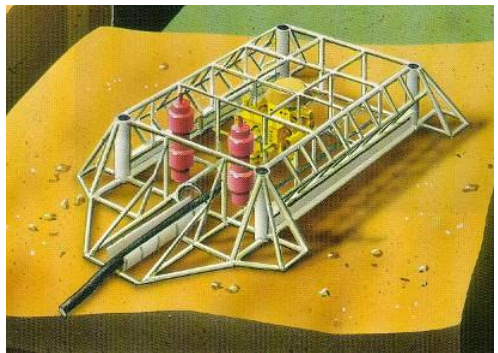

Control is from the surface where a hydraulic power unit (HPU) provides hydraulic power to the subsea installation via an **umbilical**. The umbilical is a composite cable containing tension wires, hydraulic pipes, electrical power and control and communication signals. A control pod with inert gas and/or oil protection contains

control electronics, and operates most equipment Subsea via hydraulic switches. More complex Subsea solutions may contain subsea separation/stabilization and electrical multiphase pumping. This may be necessary if reservoir pressure is low, offset (distance to main facility) is long or there are flow assurance problems so that the gas and liquids will not stably flow to the surface.

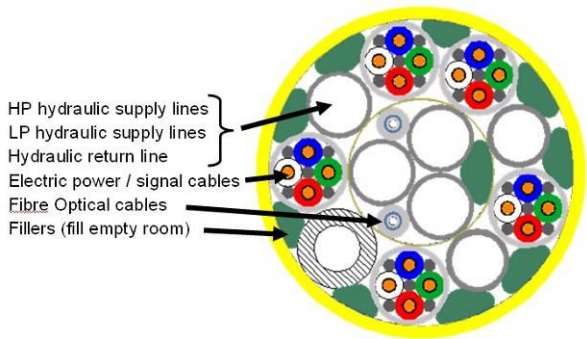

Product is piped back through pipelines and risers to the surface. The main choke may be located topside.

3.5.2 Injection

Wells are also divided into production and injection wells. The former is for production of oil and gas, injection wells is drilled to inject gas or water into the reservoir. The purpose of injection is to maintain overall and hydrostatic reservoir pressure and force the oil toward the production wells. When injected water reaches the production well, this is called injected water break through. Special logging instruments, often based on radioactive isotopes added to injection water, are used to detect breakthrough.

Injection wells are fundamentally the same as production wellheads other than the direction of flow and therefore the mounting of some directional component such as the choke.

3.6 Artificial Lift

Production wells are free flowing or lifted. A free flowing oil well has enough downhole pressure to reach a suitable wellhead production pressure and maintain an acceptable well-flow. If the formation pressure is too low, and water or gas injection cannot maintain pressure or is not suitable, then the well must be artificially lifted. For smaller wells, 0.7 MPa (100 PSI) wellhead pressure with a standing column of liquid in the tubing is considered a rule-of-thumb to allow the well to flow. Larger

wells will be equipped with artificial lift to increase production even at much higher pressures. Some artificial lift methods are:

3.6.1 Rod Pumps

Sucker Rod Pumps, also called Donkey pumps or beam pumps, are the most common artificial-lift system used in land-based operations. A motor drives a reciprocating beam, connected to a polished rod passing into the tubing via a stuffing box. The sucker rod continues down to the oil level and is connected to a plunger with a valve.

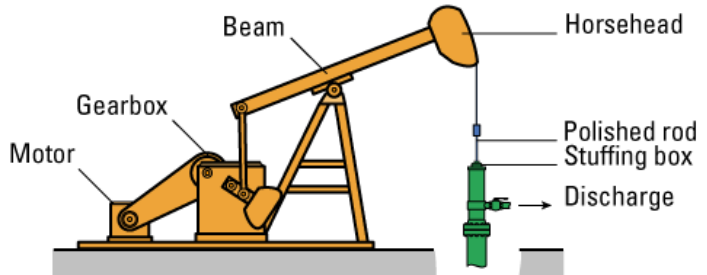

On each upward stroke, the plunger lifts a volume of oil up and through the wellhead discharge. On the downward stroke it sinks (it should sink, not be pushed) with oil flowing through the valve. The motor speed and torque is controlled for efficiency and minimal wear with a Pump off Controller (PoC). Use is limited to shallow reservoirs down to a few hundred meters, and flows up to about 40 liters (10 gal) per stroke.

3.6.2 Downhole Pumps

Downhole pump insert the whole pumping mechanism into the well. In modern installations, an Electrical Submerged Pump (ESP) is inserted into the well. Here the whole assembly consisting of a long narrow motor and a multi phase pump, such as a PCP (progressive cavity pump) or centrifugal pump, hangs by an electrical cable with tension members down the tubing. *Ill: Wikipedia.org*

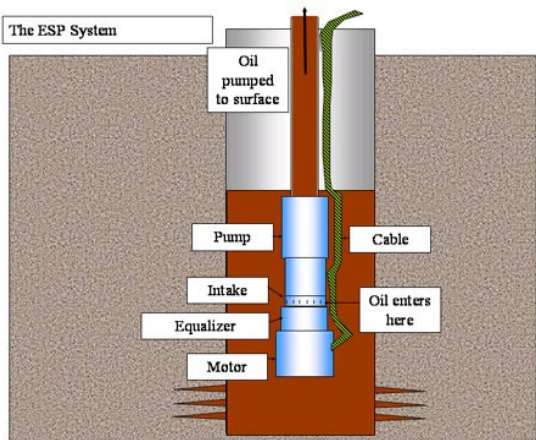

Installations down to 3.7 km with power up to 750 kW have been installed. At these depths and power ratings, Medium Voltage drives (up to 5kV) must be used.

ESPs works in deep reservoirs, but lifetime is sensitive to contaminants such as sand, and efficiency is sensitive to GOR (Gas Oil Ratio) where gas over 10% dramatically lowers efficiency.

3.6.3 Gas Lift

Gas Lift injects gas into the well flow. The downhole reservoir pressure falls off to the wellhead due to the counter pressure from weight of the oil column in the tubing. Thus a 150 MPa reservoir pressure at 1600 meters will fall to zero wellhead pressure if the specific gravity is 800 kg/m². (0,8 times water). By injecting gas into this oil, the specific gravity is lowered and the well will start to flow. Typically gas is injected between casing and tubing, and a release valve on a gas lift mandrel is inserted in the tubing above the

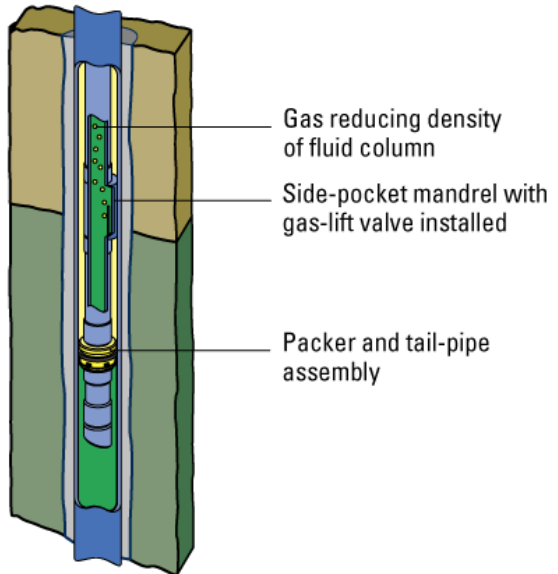

packer. The valve will open at a set pressure to inject lift gas into the tubing. Several mandrels with valves set at different pressure ranges can be used to improve lifting and start up. *Ill: Schlumberger oilfield glossary*

Gas lift can be controlled for a single well to optimize production, and to reduce slugging effects where the gas droplets collect to form large bubbles that can upset production.

Gas lift can also be optimized over several wells to use available gas in the most efficient way.

3.6.4 Plunger Lift

Plunger lift is normally used on low pressure gas wells with some condensate, oil or water, or high gas ratio oil wells. In this case the well flow conditions can be so that liquid starts to collect downhole and eventually blocks gas so that the well production stops. In this case a plunger with an open/close valve can be inserted in the tubing. A plunger catcher at the top opens the valve and can hold the plunger, while another mechanism downhole will close the valve.

The cycle starts with the plunger falling into the well with its valve open. Gas, condensate and oil can pass through the plunger until it reaches bottom. There the valve is closed, now with a volume of oil, condensate or water on top. Gas pressure starts to accumulate under the plunger and after some time pushes the plunger upwards, with liquid on top, which eventually flows out of the wellhead discharge.

When the plunger reaches the wellhead plunger catcher, the valve opens and allows gas to flow freely for some time while new liquid collects at the bottom. After some preset time the catcher will release the plunger, and the cycle repeats.

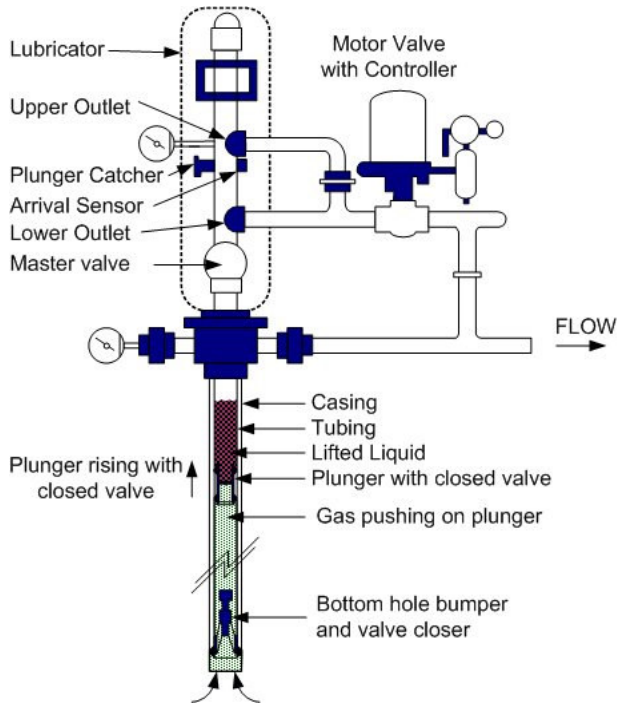

3.7 Well workover, intervention and stimulation.

After some time in operation, the well may become less productive or faulty due to residue build up, sand erosion, corrosion or reservoir clogging.

Well workover is the process of performing major maintenance on an oil or gas well. This might include replacement of the tubing, cleanup or new completions, new

perforation and various other maintenance works such as installation of gas lift mandrels, new packing etc.

Through-tubing workover operations are work performed with special tools that do not necessitate the time consuming full workover procedure including replacement or removal of tubing. Well maintenance without killing the well and performing full workover is time saving and is often called **well intervention**. Various operations that are performed by lowering instruments or tools on a wire into the well are called **wireline operations**.

Work on the reservoir such as chemical injection, acid treatment, heating etc is referred to as **reservoir stimulation**. Stimulation serves to correct various forms of formation damage and improve flow. Damage is a generic term for accumulation of particles and fluids that block fractures and pores and limit reservoir permeability.

- Acids, such as HCL (Hydrochloric Acid) are used open up calcareous reservoirs and to treat accumulation of calcium carbonates in the reservoir structure around the well. Several hundred liters of acid (typically 15% solution in water) are pumped into the well under pressure to increase permeability of the formation. When the pressure is high enough to open fractures, the process is called fracture acidizing. If the pressure is lower, it is called matrix acidizing.
- Hydraulic fracturing is an operation in which a specially blended liquid is pumped down a well and into a formation under pressure high enough to cause the formation to crack open, forming passages through which oil can flow into the well bore. Sand grains, aluminum pellets, walnut shells, glass beads, or similar materials (propping agents) are carried in suspension by the fluid into the fractures. When the pressure is released at the surface, the fractures partially close on the proppants, leaving channels for oil to flow through to the well. The fracture channels may be up to 100 meters, several hundred feet long.
- Explosive fracturing, when explosives are used to fracture a formation. At the moment of detonation, the explosion furnishes a source of high-pressure gas to force fluid into the formation. The rubble prevents fracture healing, making the use of proppants unnecessary.
- Damage removal refers to other forms of removing formation damage, such as flushing out of drill fluids.

Flexible **coiled tubing** can be wound on a large diameter drum and can be inserted and removed much quicker than tubing installed from rigid pipe segments. Well workover equipment including coiled tubing is often mounted on well workover rigs.

3.8 Unconventional sources of oil and gas

The descriptions above are valid for conventional oil and gas sources. As demand increases, prices soar and new conventional resources become harder to find, production of oil and gas from unconventional sources become more attractive. These unconventional sources include very heavy crudes, oil sands, oil shale, gas and synthetic crude from coal, coal bed methane and biofuels. Estimates for conventional proven producible oil and gas reserves vary somewhat. The current increase in consumption is just under 2 % per year, or 15% - 20% in a decade for different products, even with energy saving efforts. If this trend continues the time to go figures quoted above will be reduced by one third.

The following table shows current estimates and consumption:

2006	Proven reserves (average)	Barrels Oil Equivalent (OE)	Daily OE consumption	Time to go at current consumption
Crude Oil	1100 billion bl	1100 bill bl	76 mill bl	40 years
Natural gas	175 trillion scm	1150 bill bl	47 mill bl	67 years

Estimates on undiscovered conventional and unconventional sources vary widely as the oil price; economical production cost and discovery are uncertain factors. With continued high oil prices, figures around 1-2 trillion barrels conventional (more gas than oil) and 3 trillion barrels unconventional are often quoted, for a total remaining producible hydrocarbon reserve of about 5 trillion barrels oil equivalent. Within a decade, it is expected that up to a third of oil fuel production may come from unconventional sources.

3.8.1 Extra Heavy Crude

Very Heavy crude are hydrocarbons with an API grade of about 15 or below. The most extreme heavy crude currently extracted are Venezuelan 8 API crude e.g. in eastern Venezuela (Orinoco basin). If the reservoir temperature is high enough, the crude will flow from the reservoir. In other areas, such as Canada, the reservoir temperature is lower, and steam injection must be used to stimulate flow from the formation.

When reaching the surface, the crude must be mixed with a diluent (often LPGs) to allow it to flow in pipelines. The crude must be **upgraded** in a processing plant to make lighter **SynCrude** with a higher yield of high value fuels. Typical SynCrude have an API of 26-30. The diluent is recycled by separating it out and piped back to the wellhead site. The crude undergoes several stages of hydrocracking and coking to form lighter hydrocarbons and remove coke. It is often rich in sulfur (sour crude) which must be removed.

3.8.2 Tar sands

Tar sands can be often strip mined. Typically two tons of tar sand will yield one barrel of oil. A typical tar sand contains sand grains with a water envelope, covered by a bitumen film that may contain 70% oil. Various fine particles can be suspended in the water and bitumen.

This type of tar sand can be processed with water extraction. Hot water is added to the sand, and the resulting slurry is piped to the extraction plant where it is agitated and the oil skimmed from the top. Provided that the water chemistry is appropriate (adjusted with chemical additives), it allows bitumen to separate from sand and clay. The combination of hot water and agitation releases bitumen from the oil sand, and allows small air bubbles to attach to the bitumen droplets. The bitumen froth floats to the top of separation vessels, and is further treated to remove residual water and fine solids. It can then be transported and processed the same way as for extra heavy crude.

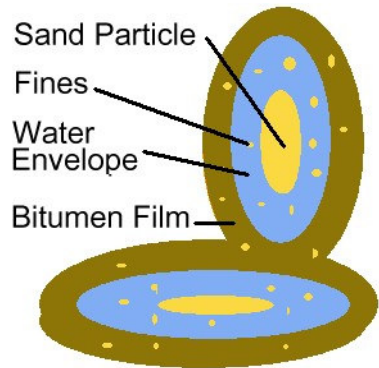

It is estimated that around 80% of the tar sands are too far below the surface for the current open-pit mining technique. Techniques are being developed to extract the oil below the surface. These techniques requires a massive injection of steam into a deposit, thus liberating the bitumen underground, and channeling it to extraction points where it would be liquefied before reaching the surface. The tar sands of Canada (Alberta) and Venezuela are estimated at 250 billion barrels, equivalent to the total reserves of Saudi Arabia

3.8.3 Oil Shale

Most oil shales are fine-grained sedimentary rocks containing relatively large amounts of organic matter from which significant amounts of shale oil and combustible gas can be extracted by destructive distillation. One of the largest known locations is the oil shale locked in the 40,000 km² (16000 sq-mile) Green River Formation in Colorado, Utah, and Wyoming.

Oil shale differs from coal whereby the organic matter in shales has a higher atomic Hydrogen to Carbon ratio. Coal also has an organic to inorganic matter ratio of more than 4,75 to 5 while as oil shales have a higher content of sedimentary rock. Sources estimate the world reserves of Oil Shales at more than 2,5 trillion barrels.

Oil shales are thought to form when algae and sediment deposit in lakes, lagoons and swamps where an anaerobic (oxygen free) environment prevent the breakdown of organic matter, thus allowing it to accumulate in thick layers. Thet is later covered with overlying rock to be baked under high temperature and pressure. However heat and pressure was lower than in oil and gas reservoirs. The shale can be strip mined and processed with distillation. Extraction with fracturing and heating is still relatively unproven. Companies are experimenting with direct electrical heating rather than e.g. steam injection. Extraction cost is currently around 25-30 USD per barrel.

3.8.4 Coal, Coal Gasification and Liquefaction

Coal is similar in origin to oil shales but typically formed from anaerobic decay of peat swamps relatively free from nonorganic sediment deposits, reformed by heat and pressure. To form a 1 meter thick coal layer, as much as 30 meters of peat was originally required. Coal can vary from relatively pure carbon to carbon soaked with hydrocarbons, sulfur etc.

It has been clear for decades that synthetic oil could be created from coal. Coal gasification will transform coal into e.g. methane. Liquefaction such as the Fischer-Tropsch process will turn methane into liquid hydrocarbons. (Typically on the form C_nH_{2n+2})

In addition, coal deposits contain large amounts of methane, referred to as **coal bed methane**. It is more difficult to produce than normal natural gas (which is also largely methane), but could add as much as 5-10% to natural gas proven reserves.

3.8.5 Methane Hydrates

Methane hydrates are the most recent form of unconventional natural gas to be discovered and researched. These formations are made up of a lattice of frozen water, which forms a sort of cage around molecules of methane. Hydrates were first discovered in permafrost regions of the Arctic and have been reported from most deepwater continental shelves tested. The methane can



originate from organic decay. At the sea bottom, under high pressure and low temperatures, the hydrate is heavier than water and will not escape, but stay at the bottom. Research has revealed that they may be much more plentiful than first expected. Estimates range anywhere from 180 to over 5800 trillion scm. The US Geological Survey estimates that methane hydrates may contain more organic carbon than the world's coal, oil, and conventional natural gas – combined. However, research into methane hydrates is still in its infancy.

3.8.6 Biofuels

Biofuels are produced from specially grown products such as oil seeds or sugars, and organic waste e.g. from the forest industry.

Alcohol is distilled from fermented sugars and/or starch (e.g. wood or grain) to produce Ethanol that can be burnt alone, or mixed with ordinary petrol.

Biodiesel is made through a chemical process called transesterification whereby the glycerin is separated from fat or vegetable oil. The process leaves behind two products -- methyl esters (the chemical name for biodiesel) and glycerin (a valuable byproduct usually sold to be used in soaps and other products). Biodiesel contains no petroleum, but it can be blended at any level with petroleum diesel to create a biodiesel blend. It can be used in compression-ignition (diesel) engines with little or no modifications. Biodiesel is simple to use, biodegradable, nontoxic, and essentially free of sulfur and aromatics.

Brazil and Sweden are two countries with full scale biofuel programs.

3.8.7 Hydrogen

Although not a hydrocarbon resource, hydrogen can be used in place of or complement traditional hydrocarbon based fuels. Hydrogen is clean burning, which means that when hydrogen reacts with oxygen, either in a conventional engine or a fuel cell, water vapor is the only emission. (Combustion with air at high temperatures will also form nitrous oxides).

Hydrogen can be produced either from hydrocarbons (natural gas, ethanol etc.) or by electrolysis. Production from natural gas (catalytic: $\text{CH}_4 + \frac{1}{2} \text{O}_2 \rightarrow 2\text{H}_2 + \text{CO}$, $\text{CO} + \frac{1}{2} \text{O}_2 \rightarrow \text{CO}_2$) also produces energy and carbon dioxide, but has the advantage over methane gas that carbon dioxide can be removed and handled at a central location rather than from each consumer (car, ship etc.), providing a cleaner **energy source**.

Hydrogen is also produced with electrolysis from water, or in various recycling processes in the chemical industry. (e.g. Hydrochloric acid recycle in the polyurethane

process). The energy requirement can then come from a renewable source such as hydroelectric, solar, wind, wave, or tidal, where hydrogen acts as an **energy transport medium** replacing bulky batteries, to form a full clean, renewable energy source supply chain.

In both cases the main problem is overall economy, distribution and storage from the fact that hydrogen cannot easily be compressed to small volumes, but requires quite bulky gas tanks for storage.

4 The Oil and Gas Process

The oil and gas process is the process equipment that takes the product from the wellhead manifolds and delivers stabilized marketable products, in the form of Crude Oil, Condensate or Gas. Components of the process also exist to test products and clean waste products such as produced water.

Our example process, for the Norsk Hydro Njord floater is shown on the next page. This is a medium size platform with one production train and a production of 40-45.000 barrels per day (bpd). This is actual production, after separation of water and gas. The associated gas and is used for on board power generation and gas reinjection. There is only



one separation and gas compression train. The water is treated and released (it could also have been reinjected). This process is quite representative for hundreds of similar size installations, and only more complete gas treatment and gas export is missing to form a complete gas production facility, Njord sends the oil via a short pipeline to a nearby storage floater. On gravity base platforms, FPSO (Floating Production and Storage Operations) and onshore plants this storage will be a part of the main installation if the oil is not piped out directly. *Photo: Norsk Hydro ASA*

A large number of connections to chemicals, flare etc are shown, these systems are described separately.

Njord main process illustration: Norsk Hydro ASA

MAIN PROCESS - NJORD

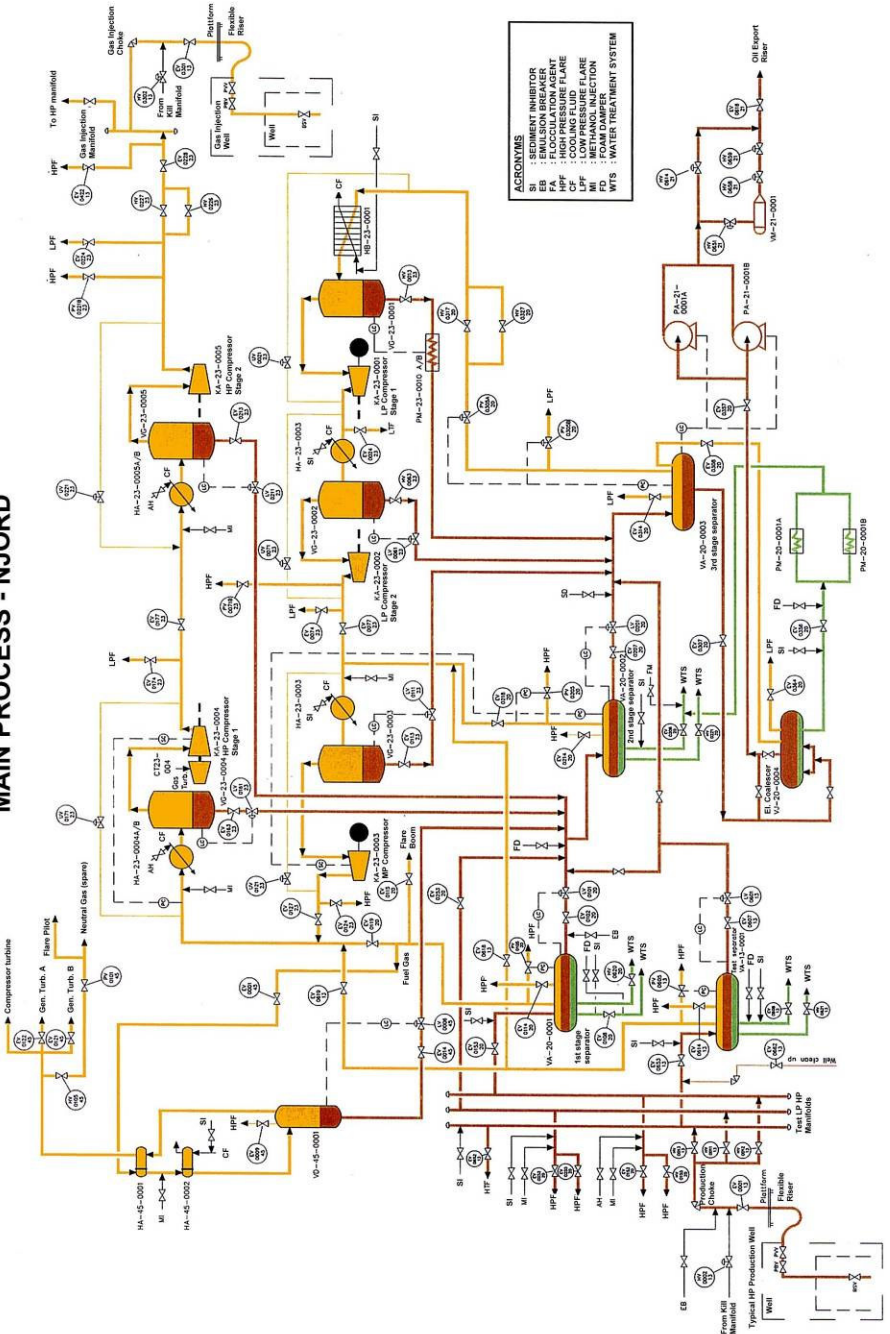

4.1 Manifolds and Gathering

4.1.1 Pipelines, and Risers

This facility uses Subsea production wells. The typical High Pressure (HP) wellhead at the bottom right, with its Christmas tree and choke, is located on the sea bottom. A production riser (offshore) or gathering line (onshore) brings the well flow into the manifolds. As the reservoir is produced, wells may fall in pressure and become Low Pressure (LP) wells.

This line may include several check valves. The choke, master and wing valves are relatively slow, therefore in case of production shutdown, pressure before the first closed sectioning valve will rise to the maximum wellhead pressure before these valves can close. The pipelines and risers are designed with this in mind.

Short pipeline distances is not a problem, but longer distances may cause multiphase well flow to separate and form severe slugs, plugs of liquid with gas in between, traveling in the pipeline. Severe slugging may upset the separation process, and also cause overpressure safety shutdowns. Slugging might also occur in the well as described earlier. Slugging may be controlled manually by adjusting the choke, or with automatic slug controls. Further, areas of heavy condensate might form in the pipelines. At high pressure, these plugs may freeze at normal sea temperature, e.g. if production is shut down or with long offsets. This may be prevented by injecting ethylene glycol. Glocol injection is not used on Njord.

The Njord floater has topside chokes for Subsea wells. The diagram also shows that Kill Fluid, essentially high specific gravity Mud, can be injected into the well before the choke.

4.1.2 Production, test and injection manifolds

Check valves allow each well to be routed into one or more of several Manifold Lines. There will be at least one for each process train plus additional Manifolds for test and balancing purposes. In the diagram we show three: Test, Low Pressure and High Pressure Manifolds. The test manifold allows one or more wells to be routed to the test separator. Since there is only one process train, the HP and LP manifolds allow groups of HP and LP wells to be taken to the first and second stage separators respectively. The chokes are set to reduce the wellhead flow and pressure to the desired HP and LP pressures respectively.

The desired setting for each well and which wells produce at HP and LP for various production levels are defined by reservoir specialists to ensure the optimum production and recovery rate.

4.2 Separation

As described earlier, the well-stream may consist of Crude oil, Gas, Condensates, water and various contaminants. The purpose of the separators is to split the flow into desirable fractions.

4.2.1 Test Separators and Well test

Test separators are used to separate the well flow from one or more wells for analysis and detailed flow measurement. In this way, the behavior of each well under different pressure flow conditions can be determined. This normally takes place when the well is taken into production and later at regular intervals, typically 1-2 months and will measure the total and component flow rates under different production conditions. Also undesirable behavior such as slugging or sand can be determined. The separated components are also analyzed in the laboratory to determine hydrocarbon composition of the Gas oil and Condensate.

The test separator can also be used to produce fuel gas for power generation when the main process is not running. In place of a test separator one could also use a three phase flow meter to save weight.

4.2.2 Production separators

The main separators are gravity type. On the right you see the main components around the first stage separator. As mentioned the production choke reduces well pressure to the HP manifold and First stage separator to about 3-5 MPa (30-50 times atmospheric pressure). Inlet temperature is often in the range of 100-150 degrees C. On the example platform, the well stream is colder due to Subsea wells and risers.

The pressure is often reduced in several stages; here three stages are used, to allow controlled separation of volatile components. The purpose is to achieve

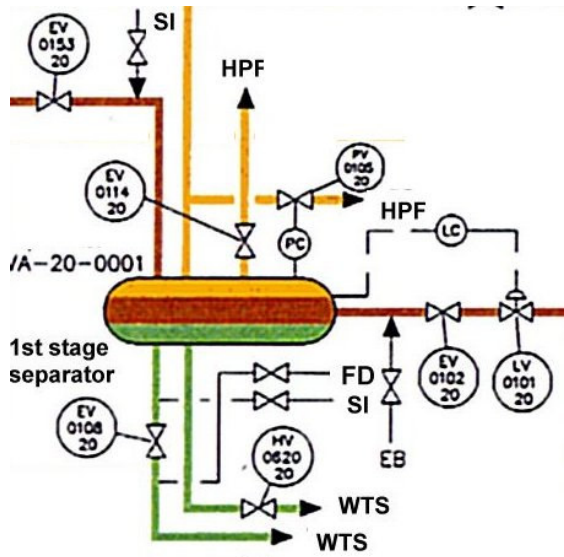

maximum liquid recovery and stabilized oil and gas, and separate water. A large pressure reduction in a single separator will cause flash vaporization leading to instabilities and safety hazards.

The retention period is typically 5 minutes, allowing the gas to bubble out, water to settle at the bottom and oil to be taken out in the middle. In this platform the water cut (percentage water in the well flow) is almost 40% which quite high. In the first stage separator, the water content is typically reduced to less than 5%.

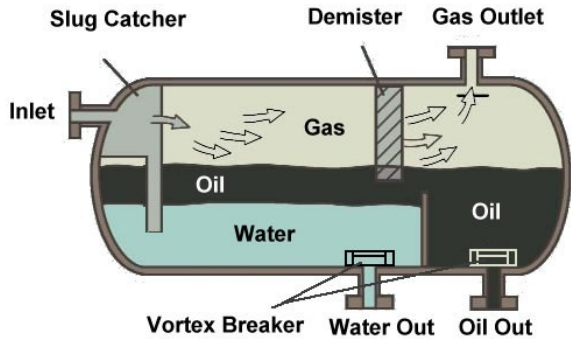

At the crude entrance there is a baffle **slug catcher** that will reduce the effect of slugs (Large gas bubbles or liquid plugs). However some turbulence is desirable as this will release gas bubbles faster than a laminar flow.

At the end there are barriers up to a certain level to keep back the separated oil and water. The main control loops are the oil level control loop (EV0101 20 above) controlling the oil flow out of the separator on the right, and the gas pressure loop at the top.(FV0105 20 above) These loops are operated by the Control System. An important function is also to prevent **gas blow-by** which happens when low level causes gas to exit via the oil output causing high pressure downstream. There are generally many more instruments and control devices mounted on the separator. These will be discussed later.

The liquid outlets from the separator will be equipped with **vortex breakers** to reduce disturbance on the liquid table inside. This is basically a flange trap to break any vortex formation and ensure that only separated liquid is tapped off and not mixed with oil or water drawn in though these vortices. Similarly the gas outlets are equipped with **demisters**, essentially filters that will remove liquid droplets in the gas.

Emergency Valves (EV) are sectioning valves that will separate the process components and blow-down valves that will allow excess hydrocarbons to be burned off in the flare. These valves are operated if critical operating conditions are detected or on manual command, by a dedicated Emergency Shutdown System. This might

involve partial shutdown and shutdown sequences since the flare might not be able to handle a full blow-down of all process sections simultaneously.

A 45,000 bpd design production with gas and 40% water cut this gives about 10 cubic meters from the wellheads per minute. There also needs to be enough capacity to handle normal slugging from wells and risers. This means the separator has to be about 100 cubic meters, e.g. a cylinder 3 m in diameter and 14 meters long. At the rated operating pressure this means a very heavy piece of equipment, typically around 50 tons for this size. This limits the practical number of stages. Other types of separators such as vertical separators, cyclones (centrifugal separation) can be used to save weight, space or improve separation (see later). There also has to be a certain minimum pressure difference between each stage to allow satisfactory performance in the pressure and level control loops.

Chemical additives are discussed later.

4.2.3 Second stage separator

The second stage separator is quite similar to the first stage HP separator. In addition to output from the first stage, it will also receive production from wells connected to the Low Pressure manifold. The pressure is now around 1 MPa (10 atmospheres) and temperature below 100 degrees C. The water content will be reduced to below 2%.

An oil heater could be located between the first and second stage separator to reheat the oil/water/gas mixture. This will make it easier to separate out water when initial water cut is high and temperature is low. The heat exchanger is normally a tube/shell type where oil passes through tubes in a cooling medium placed inside an outer shell.

4.2.4 Third stage separator

The final separator here is a two phase separator, also called a flash-drum. The pressure is now reduced to about atmospheric pressure (100 kPa) so that the last heavy gas components will boil out. In some processes where the initial temperature is low, it might be necessary to heat the liquid (in a heat exchanger) again before the flash drum to achieve good separation of the heavy components. There are level and pressure control loops.

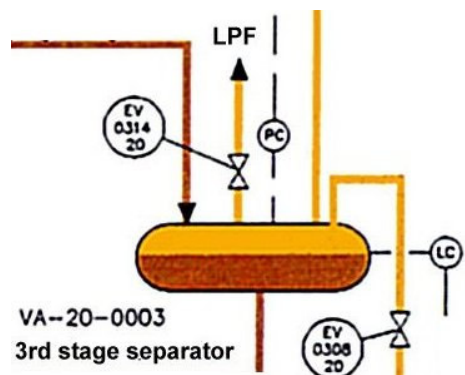

As an alternative, when the production is mainly gas, and remaining liquid droplets have to be separated out, the two phase separator can be a Knock-Out Drum (K.O. Drum).

4.2.5 Coalescer

After the third stage separator, the oil can go to a coalescer for final removal of water. In this unit the water content can be reduced to below 0.1%. The coalescer is completely filled with liquid: water at the bottom and oil on top. Inside electrodes form an electric field to break surface bonds between conductive water and isolating oil in an oil water emulsion. The coalescer field plates are generally steel, sometimes covered with dielectric material to prevent short circuits. The critical field strength in oil is in the range 0.2 to 2 kV/cm. Field intensity and frequency as well as the coalescer grid layout is different for different manufacturers and oil types.

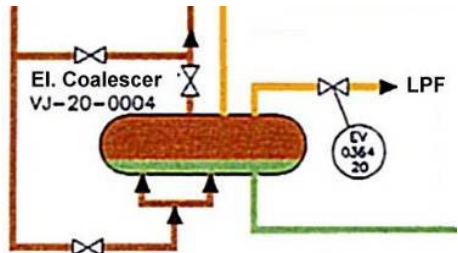

4.2.6 Electrostatic Desalter

If the separated oil contains unacceptable amounts of salts, it can be removed in an electrostatic desalter (Not used in the Njord example) The salts, which may be Sodium, Calcium or Magnesium chlorides



comes from the reservoir water and is also dissolved in the oil. The desalters will be placed after the first or second stage separator depending on Gas Oil Ratio (GOR) and Water cut. *Photo: Burgess Manning Europe PLC*

4.2.7 Water treatment

On an installation such as this, when the water cut is high, there will be a huge amount of produced water. In our example, a water cut of 40% gives a water production of about 4000 cubic meters per day (4 million liters) that must be cleaned

before discharge to sea. Often this water contains sand particles bound to the oil/water emulsion.

The environmental regulations in most countries are quite strict, as an example, in the North-East Atlantic the OSPAR convention limits oil in water discharged to sea to 40 mg/liter (ppm).

It also places limits other forms of contaminants. This still means up to one barrel of oil per day for the above production, but in this form, the microscopic oil drops are broken down fast by natural bacteria.

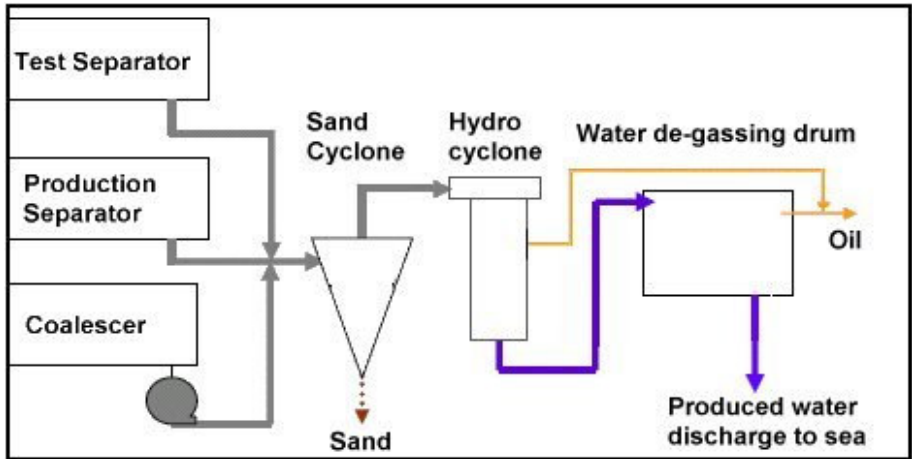

Various equipment is used; the illustration shows a typical water treatment system. Water from the separators and coalescers first goes to a **sand cyclone**, which removes most of the sand. The sand is further washed before it is discharged.

The water then goes to a **hydrocyclone**, a centrifugal separator that will remove oil drops. The hydrocyclone creates a standing vortex where oil collects in the middle and water is forced to the side.

Finally the water is collected in the **water de-gassing drum**. Dispersed gas will slowly rise to the surface and pull remaining oil droplets to the surface by flotation. The surface oil film is drained, and the produced water can be discharged to sea. Recovered oil in the water treatment system is typically recycled to the third stage separator.

4.3 Gas treatment and Compression

The gas train consist of several stages, each taking gas from a suitable pressure level in the production separator's gas outlet, and from the previous stage.

A typical stage is shown to the right. Incoming gas (on the right) is first cooled in a **heat exchanger**. It then passes through the **scrubber** to

remove liquids and goes into the compressor. The **anti surge** loop (thin orange line) and the surge valve (UV0121 23) allows the gas to recirculate. The components are described below.

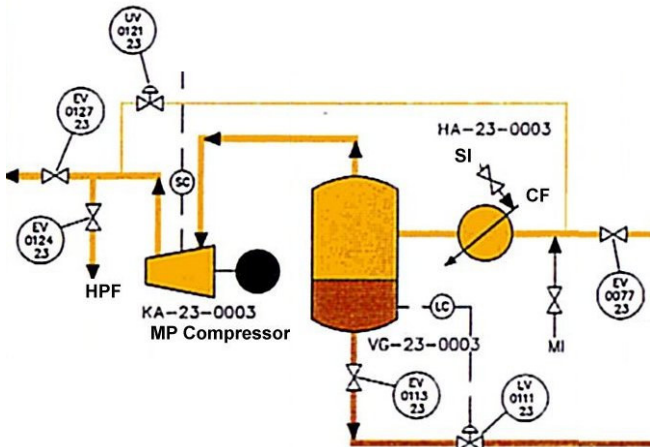

4.3.1 Heat exchangers

For the compressor operate in an efficient way, the temperature of the gas should be low. The lower the temperature is the less energy will be used to compress the gas for a given final pressure and temperature. However both gas from separators and compressed gas are relatively hot. When gas is compressed, it must remain in thermodynamic balance, which means that the gas pressure times volume over temperature (PV/T) must remain constant. ($PV = nkT$). This ends up as a temperature increase.

Temperature exchangers of various forms are used to cool the gas. Plate heat exchangers (upper picture) consist of a number of plates where the gas and cooling medium pass between alternating plates in opposing directions. Tube and shell exchangers (next

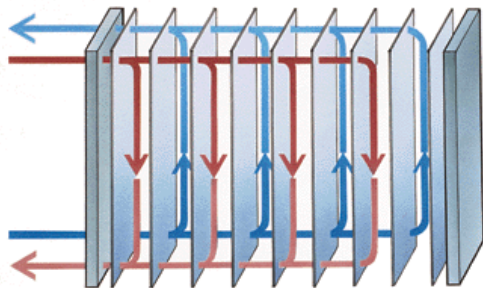

picture) place tubes inside a shell filled with of cooling fluid. The cooling fluid is often pure water with corrosion inhibitors.

When designing the process it is important to plan the thermal energy balance. Heat should be conserved e.g. by using the cooling fluid from the gas train to reheat oil in the oil train. Excess heat is disposed e.g. by sea water cooling. However hot seawater is extremely corrosive, so materials with high resistance to corrosion, such as titanium must be used. *Photo: SEC Shell and Tube Heat Exchanges*

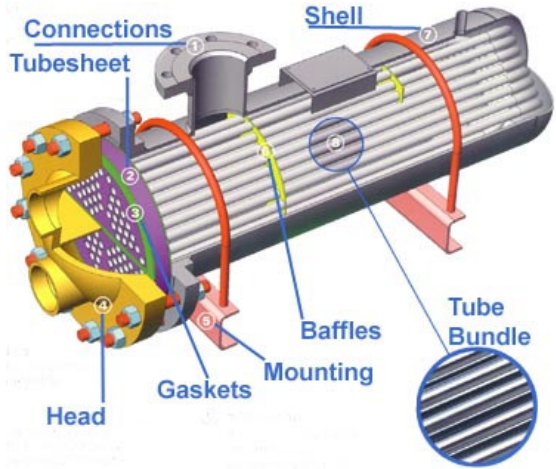

4.3.2 Scrubbers and reboilers

The separated gas may contain mist and other liquid droplets. Liquid drops of water and hydrocarbons also form when the gas is cooled in the heat exchanger, and must be removed before it reaches the compressor. If liquid droplets enter the compressor they will erode the fast rotating blades. A scrubber is designed to remove small fractions of liquid from the gas.

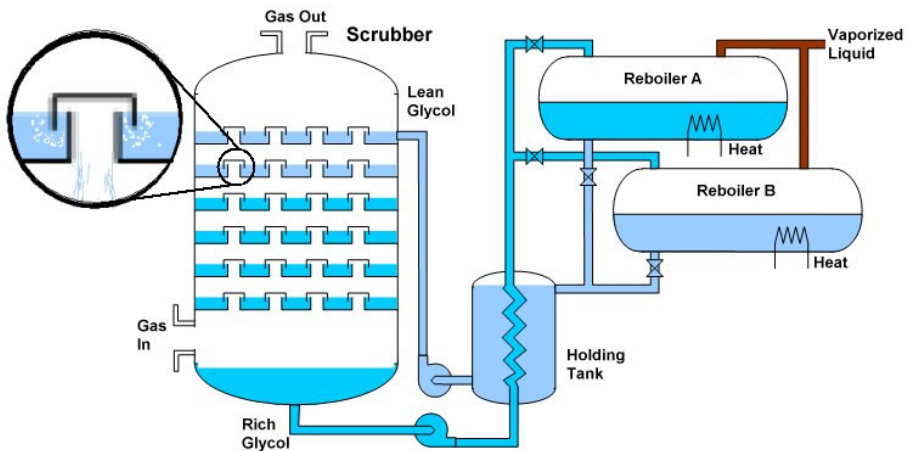

Various gas drying equipment is available, but the most common suction (compressor) scrubber is based on dehydration by absorption in Tri Ethylene Glycol (TEG). The scrubber consists of many levels of glycol layers. A large number of gas traps (enlarged detail) force the gas to bubble through each glycol layer as it flows from the bottom up each division to the top.

Lean glycol is pumped in at the top, from the holding tank. It flows from level to level against the gas flow as it spills over the edge of each trap. During this process it absorbs liquids from the gas and comes out as rich glycol at the bottom. The holding tank also functions as a heat exchanger for liquid from and to the reboilers.

The glycol is recycled by removing the absorbed liquid. This is done in the reboiler, which is filled with rich glycol and heated to boil out the liquids at temperature of about 130-180 °C (260-350°F) for a number of hours. Usually there is a distillation column on the gas vent to further improve separation of glycol and other hydrocarbons. For higher capacity there are often two reboilers which alternate between heating rich glycol and draining recycled lean glycol.

On a stand alone unit the heat is supplied from a burner that uses the recovered vaporized hydrocarbons. In other designs the heating will use a combination of hot cooling media from other parts of the process and electric heaters, and recycle the hydrocarbon liquids to the third stage separator.

4.3.3 Compressor anti surge and performance

Several types of compressors are used for gas compression, each with different characteristics such as operating power, speed, pressure and volume:

- Reciprocating Compressor that use a piston and cylinder design with 2-2 cylinders are built up to about 30 MW power, around 500-1800 rpm (lower for higher power) with pressure up to 5MPa (500 bars). Used for lower capacity gas compression and high reservoir pressure gas injection. *Photo: Ariel corp.*



- Screw compressors are manufactured up to several MW, synchronous speed (3000/3600 rpm) and pressure up to about 2.5 MPa (25 bar). Two counter rotating screws with matching profiles provide positive displacement and a wide operating range. Typical use is natural gas gathering.
Photo: Mycom/Mayekawa mfg.

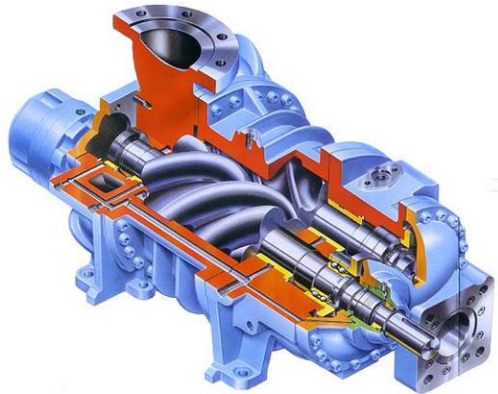

- Axial blade and fin type compressors with up to 15 wheels provide high volumes at relatively low pressure differential (discharge pressure 3-5 times inlet pressure), speeds of 5000-8000 rpm, and inlet flows to 200.000 m³/hour. Applications include air compressors and cooling compression in LNG plants. *Axial rotor photo: Dresser Rand*

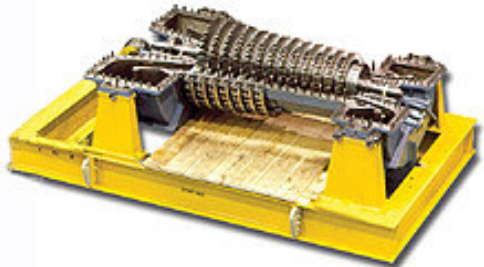

- The larger oil and gas installations use Centrifugal compressors with 3-10 radial wheels, 6000 – 20000rpm (highest for small size), up to 80 MW load at discharge pressure of up to 50bars and inlet volumes of up to 500.000 m³/hour. Pressure differential up to 10.
Photo: Dresser Rand

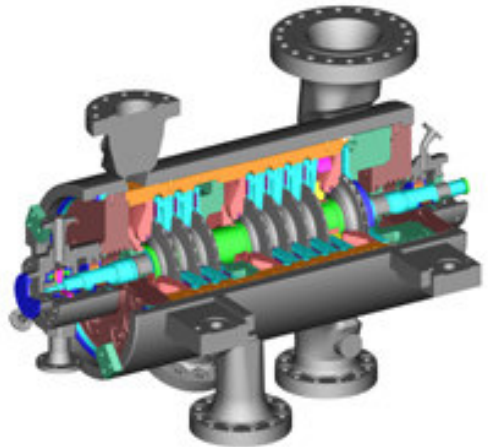

Most compressors will not cover the full pressure range efficiently. The lowest pressure is atmospheric, for gas to pipeline, some 3 to 5 MPa (30-50 bar) pressure is used, while reservoir reinjection of gas will typically require 20 MPa (200 bars) and upwards since there is no liquid in the tubing and the full reservoir pressure must be overcome. Therefore compression is divided into several stages to improve maintenance and availability. Also due to single unit power limitations compression is often divided in several parallel trains. This is not the case in the example since gas is not exported, and reinjection can be interrupted during maintenance periods.

Compressors are driven by gas turbines or electrical motors (for lower power also reciprocating engines, steam turbines are sometimes used if thermal energy is available). Often several stages in the same train are driven by the same motor or turbine.

The main operating parameters for a compressor is the flow and pressure differential. The product defines the total loading, so there is a ceiling set by the maximum design power. Further, there is a maximum differential pressure (Max P_d) and choke flow (Max Q), the maximum flow that can be achieved. At lower flow, there is a minimum pressure differential and flow before the compressor will “surge”: there is not enough gas to operate. If variations in flow are expected or difference between common shaft compressors will occur, the situation will be handled with recirculation: A high flow, high pressure differential surge control valve will open to let gas from the discharge side back into the suction side. Since this gas is heated it will also pass through the heat exchanger and scrubber not to become overheated by circulation.

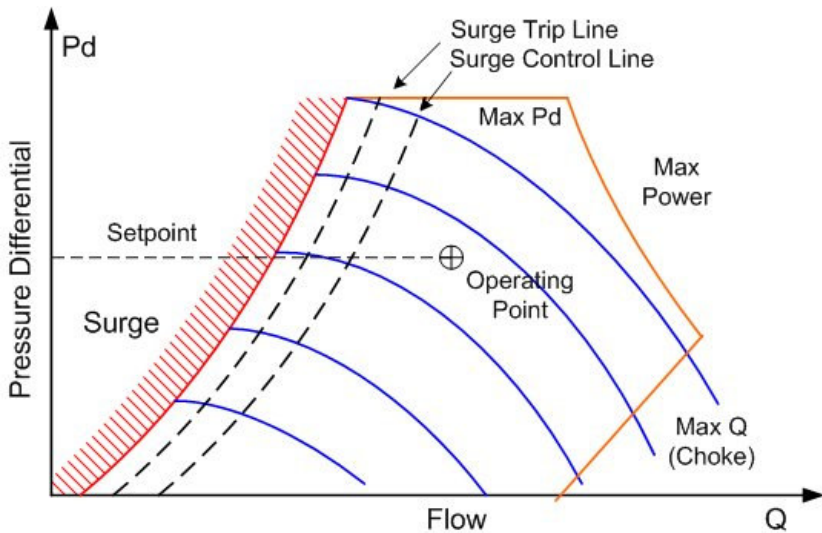

The operating characteristics are defined by the manufacturer. In the above diagram the blue lines mark constant speed lines. The maximum operating limits are set by the orange line as described above. The surge domain is the area to the left of the red surge curve.

The object of the **compressor performance control** is to keep the operating point close to the optimal setpoint without violating the constraints, by means of control outputs, such as the speed setting. However gas turbine speed control response is relatively slow and even electrical motors are not fast enough since the surge response must be in the 100 mS range. The **anti surge control** will protect the compressor from going into surge by operating the surge control valve. The basic strategy is to use distance between operating point and surge line to control the valve with a slower response time starting at the surge control line. Crossing the surge trip line will control a fast response opening of the surge valve to protect the compressor.

Operation with recirculation wastes energy (which could result in unnecessary emissions) and wear, particularly of the surge valve. Each vendor supplies several variants of compressor control and anti surge control to optimize performance, based on various corrective and predictive algorithms. Some strategies include:

- Setpoint adjustment: If rapid variations in load cause surge valve action, the setpoint will be moved to increase the surge margin.
- Equal margin: The setpoint is adjusted to allow equal margin to surge between several compressors.
- Model based control: Outside the compressor itself, the main parameter for the surge margin is the total volume from the surge valve to the compressor suction inlet, and the response time for the surge valve flow. A model predictive controller could predict surge conditions and react faster to real situations while preventing unnecessary recirculation.

Since compressors are relatively maintenance intensive and potentially expensive to replace, several other systems are normally included:

Load management: To balance loading among several compressors in a train and between trains, the compressor control system often includes algorithms for load sharing, load shedding and loading. Compressors are normally purged with inert gas, such as Nitrogen, during longer shutdowns, e.g. for maintenance. Therefore, startup and shutdown sequences will normally include procedures to introduce and remove the purge gas.

Vibration:	Vibration is a good indicator of problems in compressors, and accelerometers are mounted on various parts of the equipment to be logged and analyzed by a vibration monitoring system.
Speed governor	If the compressor is turbine driven, a dedicated speed governor handles the fuel valves and other controls on the turbine to maintain efficiency and control rotational speed. For electrical motors this function is handled by a variable speed drive.

The final function around the compressor itself is **lube and seal oil** handling. Most compressors have wet seals, which are traps around axles where oil at high pressure prevents gas from leaking out to atmosphere or other parts of the equipment. Oil is used for lubrication of the high speed bearings. This oil gradually absorbs gas under pressure and may become contaminated. So it needs to be filtered and degassed. This happens in smaller reboilers much the same way as for the glycol reboilers described earlier.

4.3.4 Gas Treatment

When the gas is exported, many gas trains include additional equipment for further gas processing, to remove unwanted components such as hydrogen sulfide and carbon dioxide. These gases are called **acids** and **sweetening** /acid removal is the process of taking them out.

Natural gas sweetening methods include absorption processes, cryogenic processes; adsorption processes (PSA, TSA and iron sponge) and membranes. Often hybrid combinations are used, such as cryogenic and membranes.

Gas treatment could also include calibration. If the delivery specification is for a specific calorific value (BTU per scf or MJ per scm) gas with higher values can be adjusted by adding an inert gas, such as nitrogen. This is often done at a common point such as a pipeline gathering system or a pipeline onshore terminal.

4.4 Oil and Gas Storage, Metering and Export

The final stage before the oil and gas leaves the platform consists of storage, pumps and pipeline terminal equipment.

4.4.1 Fiscal Metering

Partners, authorities and customers all calculate invoices, taxes and payments based on the actual product shipped out. Often custody transfer also takes place at this

point, means a transfer of responsibility or title from the producer to a customer, shuttle tanker operator or pipeline operator.

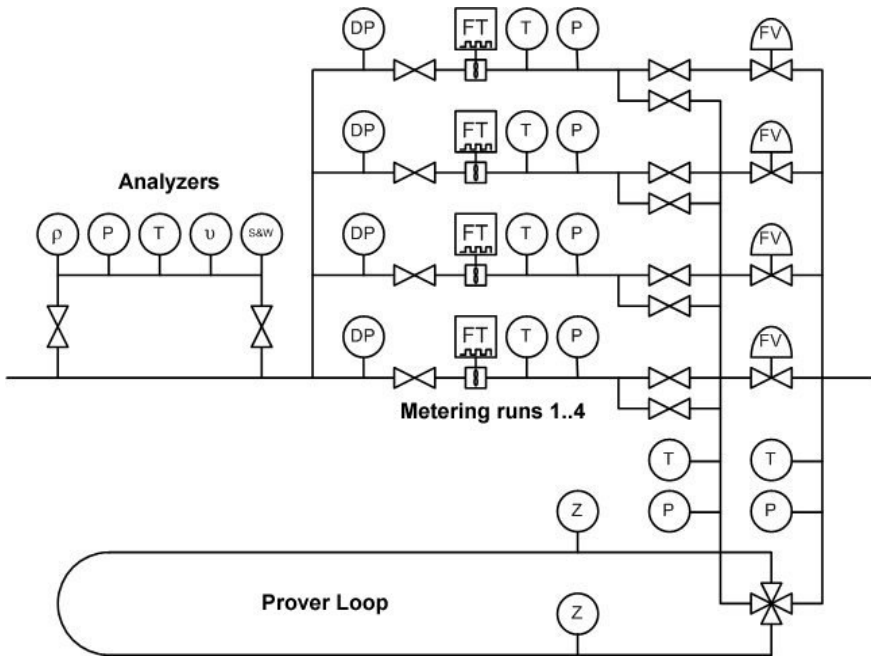

Fig. 1 Metering System

Although some small installations are still operated with dipstick and manual records, larger installations have analysis and metering equipment. To make sure readings are accurate, a fixed or movable prover loop for calibration is also installed.

The figure shows a full liquid hydrocarbon (oil and condensate) metering system. The analyzer instruments on the left provides product data such as density, viscosity and water content. Pressure and temperature compensation is also included.

For liquid, turbine meters with dual pulse outputs are most common. Alternatives are positive displacement meters (passes a fixed volume per rotation or stroke) and coriolis massflow meters. These instruments can not cover the full range with sufficient accuracy. Therefore the metering is split into several runs, and the number of runs in use depends on the flow. Each run employs one meter and several instruments to provide temperature and pressure correction. Open/Close valves allow runs to be selected and control valves can balance the flow between runs. The instruments and actuators are monitored and controlled by a flow computer. If the

interface is not digital, dual pulse trains are used to allow direction sensing and fault finding.

To obtain required accuracy, the meters are calibrated. The most common method is a prover loop. A prover ball moves through the loop, and a calibrated volume is provided between the two detectors (Z). When a meter is to be calibrated the four way valve opens to allow oil to flow behind the ball. The number of pulses from it passes one detector Z to the other is counted. After one loop the four way valve turns to reverse flow direction and the ball moves back providing the same volume and in reverse, again counting the pulses. From the known reference volume, number of pulses, pressure and temperature the flow computer can calculate the meter factor and provide accurate flow measurements using formulas from industry standard organizations such as API MPMS and ISO 5024. The accuracy is typically $\pm 0.3\%$ of standard volume.

Gas metering is similar, but instead, analyzers will measure hydrocarbon content and energy value (MJ/scm or BTU, Kcal/scf) as well as pressure and temperature. The meters are normally orifice meters or ultrasonic meters. Orifice plates with a diameter less than the pipe are mounted in cassettes. The pressure differential over the orifice plate as well as pressure and temperature is used in standard formulas (such as AGA 3 and ISO 5024/5167) to calculate normalized flow. Different ranges are accommodated with different size restrictions. Orifice plates are sensitive to build up of residue and wear on the edges of the hole. Larger new installations therefore prefer ultrasonic gas meters that work by sending multiple ultrasonic beams across the path and measure the Doppler Effect.

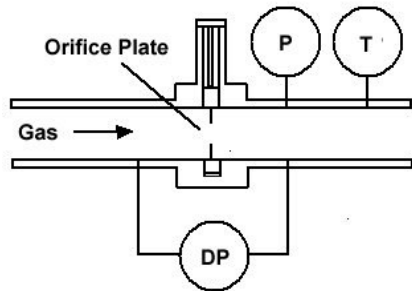

Gas metering is less accurate than liquid, typically $\pm 1.0\%$ of mass. There is usually not a prover loop, instead the instruments and orifice plates are calibrated in separate equipment.



LNG is often metered with massflow meters that can operate at the required low temperature. A three run LNG metering skid is shown above.

At various points in the movement of oil and gas, similar measurements are taken, usually in a more simplified variant. Examples are Flare gas, Fuel Gas and Injected gas where required accuracy is 2-5% percent.

4.4.2 Storage

On most production sites, the oil and gas is piped directly to a refinery or tanker terminal. Gas is difficult to store locally, but occasionally underground mines, caverns or salt deposits can be used to store gas.

On platforms without pipeline, oil is stored in onboard storage tanks to be transported by shuttle tanker. The oil is stored in storage cells around the shafts on concrete platforms, and in tanks on floating platforms. On some floaters, a separate storage tanker is used. In both cases ballast handling is important to balance the



buoyancy when the oil volume varies. For onshore fixed roof tanks are used for crude, floating roof for condensate. Also rock caverns are used.

Special tank gauging systems such as Level radars, Pressure or Float are used to measure the level in storage tanks, cells and caverns. The level measurement is converted to volume via tank strapping tables (dependent on tank geometry) and compensated for temperature to provide standard volume. Float gauges can also calculate density, and so mass can be provided.

A tankfarm consists of 10-100 tanks of varying volume for a total capacity typically in the area of 1 - 50 million barrels. Storage for shuttle tankers normally store up to two weeks of production, one week for normal cycle and one extra week for delays e.g. bad weather. This could amount to several million barrels.

Accurate records of volumes and history is kept to document what is received and dispatched. For installations that serve multiple production sites, different qualities and product blending must also be handled. Another planning task is forecasting for future received and delivered product to make sure that the required amount of sold product is available and that sufficient capacity is reserved for future received

products. A tankfarm management system keeps track of these parameters and constraints, logs the operations taking place and overall consolidation of operations.

4.4.3 Marine Loading

Loading systems consist of one or more loading arms / jetties, pumps, valves and a metering system.

Tanker loading systems are complex, both because of the volume involved, and because several loading arms will normally interact with the tanker's ballast system to control the loading operation. The



tanks must be filled in a certain sequence; otherwise the tanker's structure might be damaged due to uneven stresses. It is the responsibility of the tanker's ballast system to signal data to the loading system and to operate the different valves and monitor the tanks on board the ship.

4.4.4 Pipeline terminal

The gas pipeline is fed from the High Pressure compressors. Oil pipelines are driven by separate booster pumps. For longer pipelines, intermediate compressor stations or pump stations will be required due to distance or crossing of mountain ranges.

The pipeline terminal includes termination systems for the pipeline. At least a pig launcher and receiver will be included, to allow insertion of a pipeline pigging device that is used to clean or inspect the pipeline on the inside. This is essentially a large chamber that can be pressurized and purged to insert and remove the pig or scraper without depressurizing the pipeline. The pig is often driven by pipeline flow.

5 Utility systems

This chapter contains an overview of the various systems that provides utilities or support the main process.

5.1 Control and Safety Systems

5.1.1 Process Control

A process control system is used to monitor data and control equipment on the plant. Very small installations may use hydraulic or pneumatic control systems, but larger plants with up to 30.000 signals to and from the process require a dedicated distributed control system. The purpose of this system is to read values from a large number of sensors, run programs to monitor the process and control valves switches etc. to control the process. At the same time values, alarms, reports and other information are presented to the operator and command inputs accepted.

Process control systems consist of the following components:

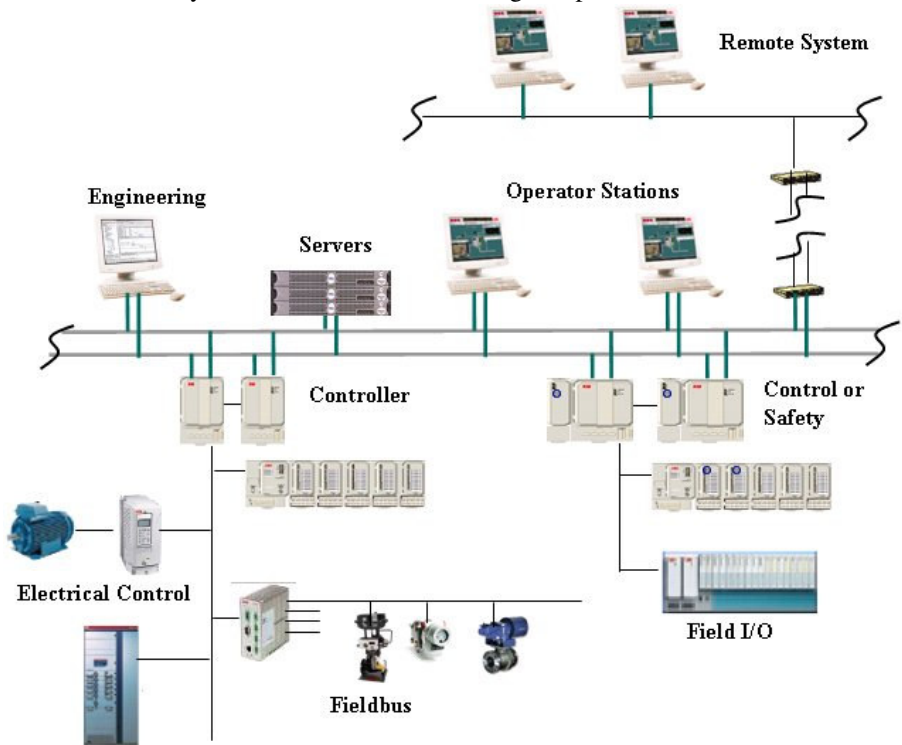

- Field instrumentation: sensors and switches that sense process conditions such as temperature, pressure or flow. These are connected over single and multiple pair electrical cables (**hardwired**) or communication bus systems called **fieldbus**.
- Control devices, such as Actuators for valves, electrical switchgear and drives or indicators are also hardwired or connected over fieldbus.
- Controllers execute the control algorithms so that desired actions are taken. The controllers will also generate events and alarms based on changes of state and alarm conditions and prepare data for operators and information systems.
- A number of servers perform the data processing required for data presentation, historical archiving, alarm processing and engineering changes.
- Clients such as operator stations and engineering stations are provided for human interfaces.
- The communication can be laid out in many different configurations, often including connections to remote facilities, remote operations support and similar.

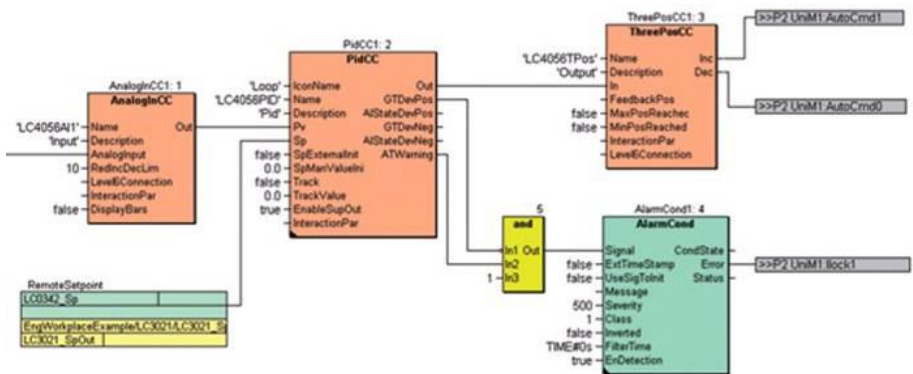

The main function of the control system is to make sure the production, processing and utility systems operate efficiently within design constraints and alarm limits. The control is typically specified in programs as a combination of logic and control function blocks such as AND, ADD, PID. For a particular system, a library of standard solutions such as Level Control Loop, Motor Control is defined. This means that the system can be specified with combinations of typical loops, consisting of one or more input devices, function blocks and output devices, rather than formal programming.

The system is operated from the Central Control Room (CCR) with a combination of graphical process displays, alarm lists, reports and historical data curves. Desk screens are often used in combination with large wall screens as shown on the right. With modern system the same information is



available to remote locations such as an onshore corporate operations support centre.

Field devices in most process areas must be protected not to act as ignition sources for potential hydrocarbon leaks. Equipment is explosive hazard classified e.g. as safe by pressurization (Ex.p), safe by explosive proof encapsulation (Ex.d) or intrinsically safe (Ex.i). All areas are mapped into explosive hazard zones from Zone 0 (Inside vessels and pipes), Zone 1 (Risk of hydrocarbons), Zone 2 (Low risk of hydrocarbons) and Safe Area.



Beyond the basic functionality the control system can be used for more advanced control and optimization functions. Some examples are:

- Well control may include automatic startup and shutdown of a well and/or a set of wells. Applications can include optimization and stabilization of artificial lift such as Pump off control and Gas lift Optimization.
- Flow assurance serves to make sure that the flow from wells, in pipelines and risers are stable and maximized under varying pressure, flow and temperatures. Unstable flow can result in slug formation, hydrates etc.
- Optimization of various processes to increase capacity or reduce energy costs.
- Pipeline Management modeling, leak detection and pig tracking
- Support for Remote Operations, where facility data is available to company specialists located at a central support center.
- Support for remote operation where the entire facility is unmanned or without local operators full or part time, and is operated from a remote location.

5.1.2 Emergency Shutdown and Process Shutdown

The process control system should control the process when it is operating within normal constraints such as level, pressure and temperature. The Emergency Shutdown (ESD) and Process Shutdown (PSD) systems will take action when the process goes into a malfunction or dangerous state. For this purpose the system maintains four sets of limits for a process value, LowLow (LL), Low (L), High (H) and HighHigh (HH). L and H are process warning limits which alert to process disturbances. LL and HH are alarm conditions and detects that the process is operating out of range and there is a chance of undesirable events and malfunction.

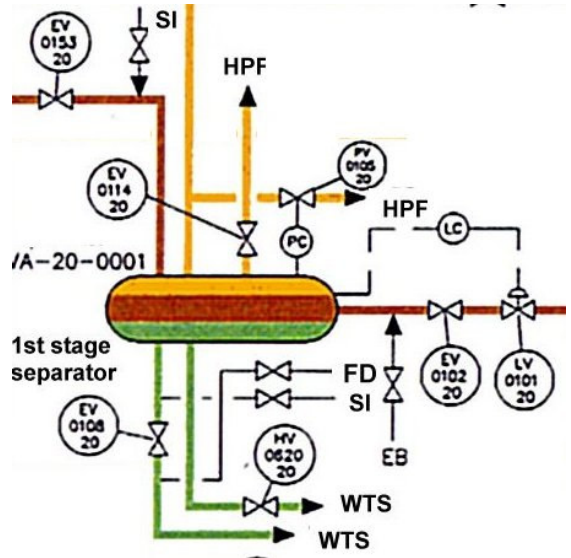

Separate transmitters are provided for safety systems. One example is the LLLL (Level Transmitter LowLow) or LSL (Level Switch Low) alarm on the oil level. When this condition is triggered, there is a risk of Blow-by which means gas leaks out of the oil output and gives high pressure in the next separation stage or other following process equipment such as a desalter. Transmitters are preferred over switches because of better diagnostics.

Emergency shutdown actions are defined in a cause and affect chart based on a study of the process. This HAZOP study identifies possible malfunctions and how they

HAZOP CAUSE & EFFECT MATRIX FOR PARAFFIN PRODUCTION SHUTDOWN (SHUTDOWN LEVEL 3) (0153)

NO.	HAZOP	CAUSE	EFFECT	CONSEQUENCE	PROTECTIVE ACTION	INITIATION	ALARM	OPERATOR ACTION	STATUS
1	EV 0133 20	SI	SI	SI	SI	SI	SI	SI	SI
2	EV 0114 20	SI	SI	SI	SI	SI	SI	SI	SI
3	EV 0105 20	SI	SI	SI	SI	SI	SI	SI	SI
4	EV 0102 20	SI	SI	SI	SI	SI	SI	SI	SI
5	EV 0101 20	SI	SI	SI	SI	SI	SI	SI	SI
6	EV 0108 20	SI	SI	SI	SI	SI	SI	SI	SI
7	MV 0620 20	SI	SI	SI	SI	SI	SI	SI	SI

should be handled. On the left of the chart we have possible emergency events; on top we find possible shutdown actions. On an oil and gas facility the primary response is to isolate and depressurize. In this case the typical action would be to close the inlet and outlet Sectioning valves (EV 0153 20, EV 0108 20 and EV 0102 20 in the diagram), and open the blowdown valve (EV 0114 20). This will isolate the malfunctioning unit and reduce pressure by flaring of the gas.

These actions are handled by the Emergency Shutdown System and Process Shutdown System.

System requirements are set by official laws and regulations and industry standards such as IEC 61508/61511, which set certification requirements for process safety systems and set criteria for the safety integrity level (SIL) of each loop.

Events are classified on a scale, e.g. 1 to 5 plus and Abandon Platform level. On this scale, the lowest level, APS means a complete shutdown and evacuation of the facility. The next levels (ESD1, ESD2) define emergency complete shutdown. The upper levels (i.e. PSD 3, PSD 4, PSD 5), represent single equipment or process section shutdowns. A split between APS/ESD and PSD is done in large installations because most signals are PSD and could be handled with less strict requirements.

The main requirements concern availability and diagnostics both on the system itself and connected equipment. The prime requirement is on demand failure, or the system's ability to react with a minimum probability, to an undesirable event with a certain time with. The second criteria is not to cause actions due to a spurious event or malfunction.

Smaller ESD systems, e.g. on wellhead platforms can be hydraulic or non-programmable..

5.1.3 Control and Safety configuration

Piping and Instrumentation Diagrams (P&ID) show the process, additional information is needed for the specification of the Process Control and Safety Systems.

The illustration shows one typical format common format for the Norwegian offshore industry: The Njård Separator 1 and 2 Systems Control Diagram (SCD). Essentially, the P&ID mechanical information has been removed, and control loops and safety interlocks drawn in with references to typical loops.

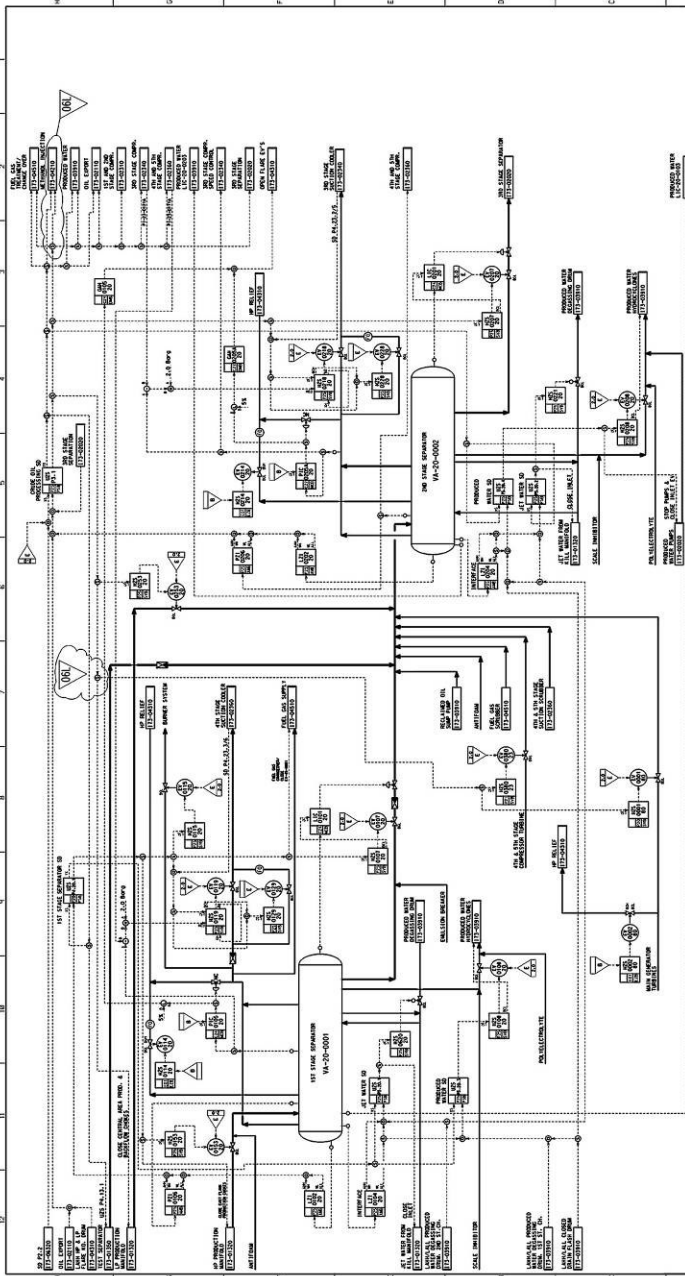

DATE	BY	NO.	REV.
08/05/2000			
01	W. J. B.	1	AS
02	W. J. B.	1	AS
03	W. J. B.	1	AS
04	W. J. B.	1	AS
05	W. J. B.	1	AS
06	W. J. B.	1	AS
07	W. J. B.	1	AS
08	W. J. B.	1	AS
09	W. J. B.	1	AS
10	W. J. B.	1	AS
11	W. J. B.	1	AS
12	W. J. B.	1	AS

NJORD

 SEPARATION

 1ST & 2ND STAGE

 PROJECT NO. 117-020010

 SHEET NO. 101

1. FOR PROCESS STARTUP SEQUENCES FOR

 2ND STAGE COMPRESSION, THE REFERENCE

 IS WA-S-713-022006

 2. FOR PROCESS STARTUP SEQUENCES FOR

 1ST STAGE COMPRESSION, THE REFERENCE

 IS WA-S-713-022009

 DRAWING ARE

 CORRECTED TO REFERENCE

 IS WA-S-713-022011

REVISIONS:

 01 - 08/05/2000

 02 - 08/05/2000

 03 - 08/05/2000

 04 - 08/05/2000

 05 - 08/05/2000

 06 - 08/05/2000

 07 - 08/05/2000

 08 - 08/05/2000

 09 - 08/05/2000

 10 - 08/05/2000

 11 - 08/05/2000

 12 - 08/05/2000

5.1.4 Fire and Gas Systems

The Fire and Gas System is not generally related to any particular process. Instead it divides into fire areas by geographical location. Each fire area should be designed to be self contained, in that it should detect fire and gas by several types of sensors, and control fire protection and fire fighting devices to contain and fight fire within the fire area. In case of fire, the area will be partially shut off by closing ventilation fire dampers. A fire area protection data sheet typically shows what detection exists for each fire area and what fire protection action should be taken in case of an undesirable event.

A separate package related to fire and gas is the diesel or electrically driven fire water pumps for the sprinkler and deluge ring systems. The type and number of the detection, protection and fighting devices depend on the type of equipment and size of the fire area and is different for e.g. process areas, electrical rooms and accommodations.

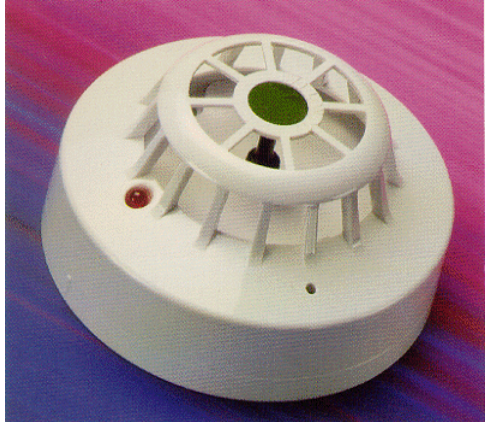

Fire detection:

- Gas detection: Combustible and Toxic gas, Electro catalytic or optical (IR) detector.
- Flame detection: Ultraviolet (UV) or Infra Red (IR) optical detectors
- Fire detection: Heat and Ionic smoke detectors
- Manual pushbuttons

Firefighting, protection:

- Gas based fire-fighting such as CO₂
- Foam based fire-fighting
- Water based fire-fighting: Sprinklers, Mist (Water spray) and deluge
- Protection: Interface to emergency shutdown and HVAC fire dampers.
- Warning and escape: PA systems, beacons/lights, fire door and damper release

For detection, coincidence and voting is often used to false alarms. In such schemes, it is required that several detectors in the same area detect a fire condition or gas leakage for automatic reaction. This will include different detection principles e.g. to trig on fire but not welding or lightening.

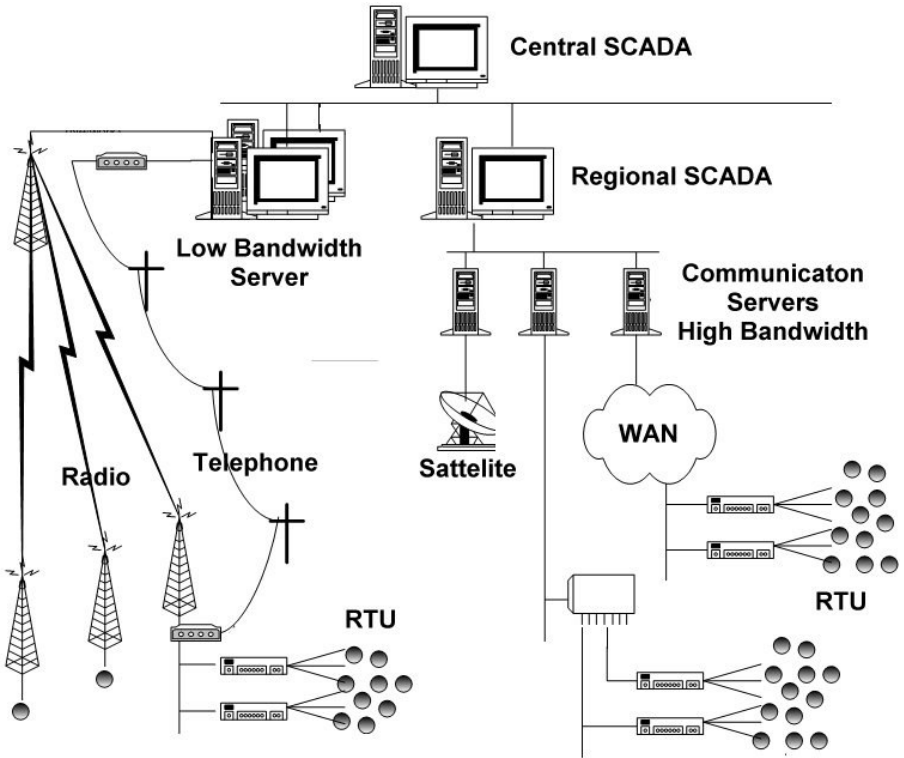

same functions as the control system, and the difference mainly comes down to data architecture and use of communications.

5.1.6 Condition Monitoring and Maintenance Support

Condition monitoring encompasses both structural monitoring and condition monitoring for process equipment such as valves and rotating machinery.

For structural monitoring, the devices are corrosion meters (essentially plates that corrode, and where that corrosion may be metered), tension force meters and free swinging strings. These are logged to a central structure condition monitoring system, to portray the forces acting on the installation, and the effect those forces are having.

Condition monitoring of machinery is generally used for large rotating apparatus, such as turbines, compressors, generators and large pumps. Input devices are vibration meters, temperature (bearing, exhaust gases etc.) as well as number of start/stops, running time, lubrication intervals and over-current trips. These values

are logged and compared with reference values to detect abnormal conditions and indicate when preventive maintenance is required or an equipment fault occurs (i.e. maintenance triggers)

For other process equipment such as valves the system can register closing times, flow and torque. A valve which exhibits a negative trend in closing time or torque (“sticktion”) can be diagnosed. Generally “maintenances triggers” are based on equipment diagnostics to predict when preventive maintenance is required. Fieldbus mounted transmitters and actuators are particularly well suited to condition monitoring diagnostics.

Maintenance support functionality will plan maintenance based on input from condition monitoring systems and a periodic maintenance plant. This will allow the system to schedule personnel for such tasks as lubrication or cleaning, and plan larger tasks such as turbine and compressor periodic maintenance.

5.1.7 Production Information Management Systems (PIMS)

A specific information management system can be used to provide information about the operation and production of the facility. This can be a separate system, or an integral part of the control system or SCADA system.

For Oil and Gas, PIMS functionality includes:

- Oil & Gas Production Reporting.
- Safety Management
- Maintenance
- Operator Support
- Overall systems integration and external
- Historical data including post failure “flight recorder” data



Some of the application provided by a PIMS system may be:

- Well Test application.
- Production Allocation (oil/gas/water) based on Well Test results.
- Metering data from integrated metering system.
- Volume in storage cells & consolidation of produced stored and dispatched volumes.
- Safety data, alarms & operators comments.
- Drilling data acquisition and drilling data logging

- Safety report, including shutdown analysis
- Operation logs
- Operator Procedures
- Laboratory data & data from administrative systems.

5.1.8 Training Simulators

Training Simulators are used to provide realistic operator training in a realistic plant training environment. Training simulators uses the actual control and safety applications of the plant, running in operator stations. Plant models simulate the feedback from the plant in real time or fast/slow motion. The training simulator applications include functions for backup and reload including recreation of historical information and snapshots. Offsite training facilities are often connected (read only) to the live plant to give information from the real operating situation.



5.2 Power generation and distribution

Power can be provided from mains power or from local diesel generator sets. Large facilities have great power demands, from 30 MW and upwards to several hundred MW. There is a tendency to generate electric power centrally and use electric drives for large equipment rather than multiple gas turbines, as this decreases maintenance and increases uptime.

The power generation system on a large facility is usually several gas turbines driving electric generators, 20-40 MW each. If exhaust heat is not needed in the main process, it can be used to drive exhaust steam turbines (so called dual cycle) for additional efficiency.

Voltage levels for High, Medium and Low voltage distribution boards are 13- 130kV, 2-8 kV and 300-600 V respectively. Power is generated and exchanged with mains or other facilities on the HV distribution board. Relays



are used for protection functions

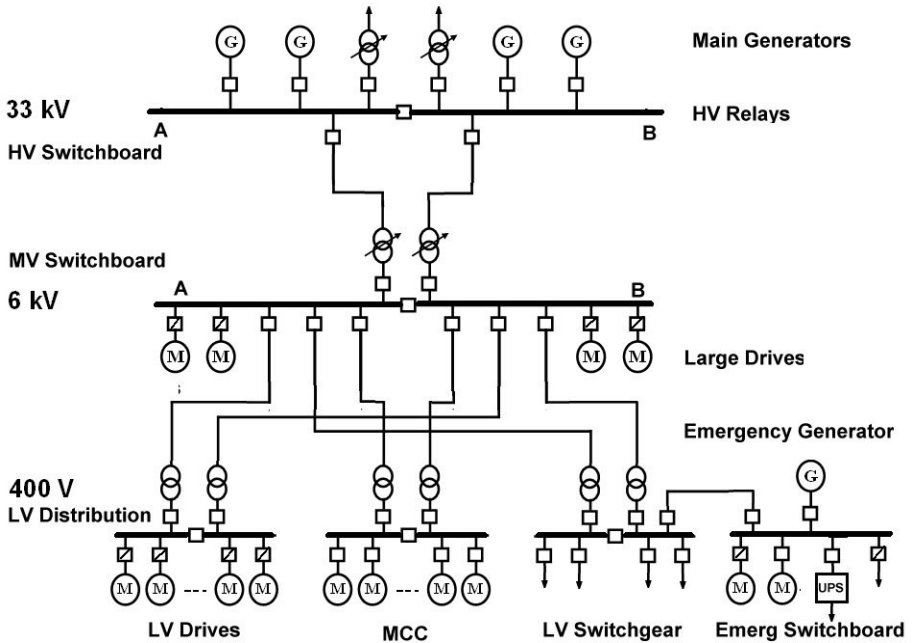

HV is transformed to MV switchboards where large consumers are connected. The LV switchboards feed a mix of normal consumers, Motor Control centers and variable speed drives for motors up to a few hundred KW (Not necessarily separate as shown in the figure).

A separate emergency power switchboard provides power for critical equipment. It can be powered from a local emergency generator if main power is lost. Computer systems are fed from an Uninterruptible Power System (UPS) connected to the emergency switchboard and/or a battery bank.

A power management system is used for control of electrical switchgear and equipment. Its function is to optimize electricity generation and usage and to prevent major disturbances & plant outages (blackouts). The power management system includes HV, MV and LV low voltage switchgear as well as Motor Control Centers (MCC) and emergency generator sets. Functions include prioritization of loads, emergency load shedding (closing down of non-essential equipment) and prestart of generator sets (e.g. when additional power to start a big crude pump is required)

Large rotating equipment and the generators are driven by gas turbines or large drives. Gas turbines for oil and gas duty are generally modified aviation turbines in the 10-25 MW range. These require quite extensive maintenance and have a relatively low overall efficiency (20-27% depending on application). Also, while the turbine is relatively small and light, it will usually require large and heavy support equipment such as large gears, air coolers/filters, exhaust units, sound damping and lubrication units.



Therefore use of large variable speed drives is becoming more common. For pumps on Subsea facilities this is the only option. For use on remote facilities, High Voltage DC transmission and HV motors can be used, from a main facility or power from shore. This will also avoid local power generation at each facility and contribute to low manning or remote operation.

5.3 Flare and Atmospheric Ventilation

The flare subsystem include Flare, atmospheric ventilation and blow down. The purpose of the Flare and Vent Systems is to provide safe discharge and disposal of gases and liquids resulting from:

- Spill-off flaring from the product stabilisation system. (Oil, Condensate etc.).
- Production testing
- Relief of excess pressure caused by process upset conditions and thermal expansion.
- Depressurisation either in response to an emergency situation or as part of a normal procedure.
- Planned depressurisation of subsea production flowlines and export pipelines.

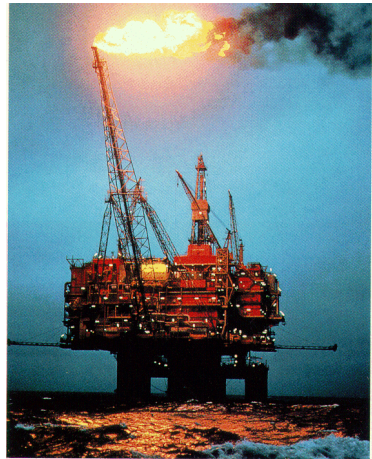

- Venting from equipment operating close to atmospheric pressure (e.g. Tanks)

The systems are typically divided into a High Pressure (HP) Flare and a Low Pressure (LP) flare system. The LP system is operated marginally above atmospheric pressure to prevent atmospheric gases such as Oxygen to flow back into the vent and flare system and create a combustible mixture. With low gas flow, inert gas is injected at the flare nozzle to prevent air ingress.

Traditionally, considerable amounts of hydrocarbons have been more or less continuously flared. In these cases, a continuously burning pilot is used to ensure ignition of hydrocarbons in the flare.

Stronger environmental focus has eliminated continuous flaring and the pilot in many areas. Vapors and flare gas are normally recovered, and only in exceptional situations does flaring occur. To avoid the pilot flame, an ignition system is used to ensure safe ignition even when large volumes are discharged. One patented solution is a “ballistic ignition” system which fires burning pellets into the flare gas flow.

5.4 Instrument air

A large volume of compressed air is required for the control of pneumatic valves and actuators, tools and purging of cabinets. It is produced by electrically driven screw compressors and further treated to be free of particles, oil and water

5.5 HVAC

The heat, ventilation and air conditioning system (HVAC) feeds conditioned air to the equipment rooms, accommodations etc. Cooling and heating is achieved by way of water cooled or water/steam heated heat exchangers. Heat may also be taken off gas turbine exhaust. In tropic and sub-tropic areas, the cooling is achieved by compressor refrigeration units. Also, in tropical areas gas turbine inlet air must be cooled to achieve sufficient efficiency and performance. The HVAC system is usually delivered as one package, and may also include air emissions cleaning. Some HVAC subsystems include:

- Cool: Cooling Medium, Refrigeration System, Freezing System
- Heat: Heat medium system, Hot Oil System.

One function is to provide air to equipment rooms that are safe by positive pressure. This prevents potential influx of explosive gases in case of a leak.

5.6 Water Systems

5.6.1 Potable Water

For smaller installations potable water can be transported in by supply vessels or tank trucks.

For larger facilities, potable water is provided on site by desalination of seawater through distillation or reverse osmosis. Onshore potable water is provided by purification of water from above ground or underground reservoirs.



Reverse osmosis requires a membrane driving pressure of about 7000 kPa / 1 PSI of pressure per 100 ppm of solids dissolved in the water. For seawater with 3,5 % salt, 2,5 MPa, 350 PSI is required. *Photo: Lenntech Water treatment & air purification Holding B.V.*

5.6.2 Seawater

Seawater is used extensively for cooling purposes. Cooling water is provided to Air Compressor Coolers, Gas Coolers, Main Generators and HVAC. In addition seawater is used for production of hypochlorite (see chemicals) and for Fire Water. Seawater is treated with hypochlorite to prevent microbiological growth in process equipment and piping.

Seawater is sometimes used for reservoir water injection. In this case a **deaerator** is used to reduce oxygen in the water before injection. Oxygen can cause microbiological growth in the reservoir. The deaerator is designed to use strip gas and vacuum.

5.6.3 Ballast Water

Ballast systems are found on drilling rigs, floating production ships and rigs as well as TLP (tension leg platforms). The object is to keep the platform level and at a certain depth under varying conditions, such as mode of operation (stationary drilling, movement), climatic conditions (elevate rig during storms), amount of produce in storage tanks, and to adjust loading on TLP tension members.

The ballasting is accomplished by way of ballast tanks, pumps and valves, which are used in combination with position measuring instruments and tension force meters (TLP) to achieve the desired ballasting.

Produced water, if available can be used as ballast to avoid salt water. Additionally, if ballast water has become contaminated from oil tanks, it must be cleaned before discharge to sea.

5.7 Chemicals and Additives

A wide range of chemical additives are used in the main process. Some of these are marked in the process diagram. The cost of process chemical additives is considerable. A typical example is antifoam where a concentration of about 150 ppm is used. With a production of 40.000 bpd, about 2000 litres (500 Gallons) of antifoam could be used. At a cost of 2 €/liter, 10 \$/Gallon in bulk, just the antifoam will cost some 4000 Euro / 5000 USD per day.



The most common chemical s and their uses are:

Scale inhibitor

The well flow contains several different contaminants such as salts, chalk, and traces of radioactive materials. As pressure and temperature changes, these may precipitate and deposit in pipes, heat exchangers, valves and tanks. As a result these may clog up or become stuck. The scale inhibitor will prevent the contaminants from separating out. Scale or sediment inhibitor is added on wellheads and production equipment.

Emulsion breaker

Water and Oil cannot mix to form a solution. However small drops of oil will disperse in water and small water drops will disperse in oil. These drops are held suspended by attractive and repulsive electrostatic forces at the molecular level. This is called an emulsion and will form a layer between the oil and water. Although the emulsion layer will eventually break down naturally, it prevents full

separation in reasonable time. An emulsion breaker is added to prevent formation of, and break down of the emulsion layer by causing the droplets to merge and grow. Sand and particles will normally be carried out by the water and be extracted in water treatment. However, the emulsion can trap these particles and sink to the bottom as a viscous sludge that is difficult to remove during operation.

Antifoam

The sloshing motion inside a separator will cause foaming. The foam will cover the fluid surface and prevent gas to escape. Also, the foam reduces the gas space inside the separator, and worst case it will pass the demister and escape to the gas outlet as mist and liquid drops. An antifoam agent is introduced upstream of the separator to prevent or break down foam formation, by reducing liquid surface tension.

Polyelectrolyte

Polyelectrolyte is added before the hydrocyclones and causes oil droplets to merge. Works by reducing surface tension and water polarity. This is also called flocculation and polyelectrolyte flocculants and allows emissions to reach 40 ppm or less.

Methanol (MEG)

Methanol or Mono Ethylene Glycol (MEG) is injected in flowlines to prevent Hydrate formation and prevent corrosion. Hydrates are crystalline compounds that form in water crystalline structures as a function of composition, temperature and pressure. Hydrates form and freeze to hydrate ice that may damage equipment and pipelines.

For normal risers, hydrates form only when production stops and the temperature start to drop. Hydrate formation can be prevented by depressurization which adds to startup time or by Methanoli injection.

On longer flowlines in cold seawater or arctic climates, hydrates may form under normal operating conditions and require continuous methanol injection. In this case the methanol can be separated and recycled.

Hydrate prediction model software can be used to determine when there is a risk for hydrate formation and to reduce methanol injection or delay depressurization.

TEG

Tri Ethylene Glycol (TEG) is used to dry gas. See scrubbers and reboilers chapter.

Hypochlorite Hypochlorite is added to seawater to prevent growth of algae and bacteria e.g. in seawater heat exchangers. Hypochlorite is produced by electrolysis of seawater to chlorine. In one variant, copper electrodes are used which adds copper salts to the solution which improves effectiveness.

Biocides Biocides are also preventive chemicals that are added to prevent microbiological activity in oil production systems such as bacteria, fungus or algae growth. Particular problems arise from growth of sulfate bacteria that produces hydrogen sulfide and clogs filters. Typical uses include diesel tanks, produced water (after hydrocyclones), and slop and ballast tanks.

Corrosion Inhibitor is injected in the export pipelines and storage tanks. Exported oil could be very corrosive and lead to corrosion of the inside of the pipeline or tank. The corrosion inhibitor will protect by forming a thin film on the metal surface.

Drag Reducers Drag reducers improve flow in pipelines. Fluid near the pipe tries to stay stationary while fluid in the center region of the pipe is moving quickly. This large difference in fluid causes turbulent bursts to occur in the buffer region. Turbulent bursts propagate and form turbulent eddies, which cause drag. Drag-reducing polymers are long-chain, ultra-high molecular weight polymers from 1 to 10 million u), with higher molecular weight polymers giving better drag reduction performance. With only parts-per-million levels in the pipeline fluid, drag-reducing polymers suppress the formation of turbulent bursts in the buffer region. The net result of using a drag-reducing polymer in turbulent flow is a decrease in the frictional pressure drop in the pipeline by as much as 70%. This can be used to lower pressure or improve throughput.

5.8 Telecom

The telecom system consists of variety of subsystems for human and computer wired and wireless communications, monitoring, observation and entertainment: Some of the main systems are:

- Public Address & Alarm System/F&G Integration
- Drillers talk back System
- UHF Radio Network System
- Closed Circuit TV System
- Mandatory Radio System
- Security Access Control
- Meteorological System/Sea Wave Radar
- Telecom Antenna Tower and Antennas
- PABX Telephone System
- Entertainment System
- Marine Radar & Vessel Movement System
- Office Data Network and Computer System
- Personnel Paging System
- Platform Personnel Registration and Tracking System
- Telecom Maintenance and Monitoring System
- Ship Communication System/PABX Extension
- Radio Link Backup System
- Mux and Fiber optical Terminal Equipment

6 Units

Some common units used in the oil and gas industry. I have listed a representative selection of US and metric units since both are used in different parts of the oil industry. The non standard factors differ slightly between different sources.

API	American Petroleum Institute crude grade	$API = (141.5 / \text{Specific gravity}) + 131,5$
Bl	Barrel (of oil)	Spec gravity = $141.5 / (API + 131,5)$ kg/l 1 Bl = 42 Gallons 1 Bl = 159 liters 1 Bl equiv. to 5487 scf = 147 scm gas
Bpd	Barrel per day	1 Bpd \approx 50 tons/tonnes per year
BTU	British Thermal Unit	1 BTU = 0,293 Wh = 1,055 kJ
CO2	CO2 emissions from hydrocarbons Typical values	1,625 Ton CO2 per Ton gas (for CH4) 1,84 Ton CO2 per Ton Crude Oil 0,94 kg per scm gas
Cal	Calorie	1 Cal = 4,187 J (Joules)
MMscf	Million Standard Cubic Feet	1 MMscf = 23.8 TOE \approx 174 barrels
psi	Pounds Per Square Inch	1 psi = 6,9 kPa = 0,069 atm
Scf	Standard Cubic Feet (of gas) Defined by energy not a normalized volume	1 scf = 1000 BTU = 252 kcal = 293 Wh = 1,055 MJ \approx 0.0268 scm
Scm	Standard Cubic metre (of gas, also Ncm) Defined by energy content	1 Scm = 39 MJ = 10.8 kWh 1 Scm \approx 37,33 Scf (not a volume conv.) 1 Scm \approx 1,122 kg
TOE	Tons oil equivalent Range 6.6 - 8 barrels at API range 8 - 52	1 TOE = 1 kilograms = 1 Ton (metric) oil 1 TOE = 1 Tonne oil (US) 1 TOE \approx 7,33 Barrels (at 33 API) 1 TOE \approx 42,9 GJ = 11,9 MWh 1 TOE \approx 40,6 MMBTU 1 TOE \approx 1,51 ton of coal 1 TOE \approx 0,79 ton LNG 1 TOE \approx 1125 Scm = 42000 Scf
kWh	kiloWatthour = 1000 Joules * 3600 S	1 kWh = 3,6 MJ = 860 kcal = 3413 BTU

Product specific gravity, API grades

Product	Liters Per Ton (metric)	API Grade	Specific Gravity (kg/m ³)	Barrels per Ton At 60°F
LPG	1835	10	1000	6,29
Jet A-1	1254	18	934	6,73
Gasoline premium/super	1353	25	904	6,98
Gasoline regular	1418	30	876	7,19
Kerosene	1273	33	860	7,33
Gas Oil	1177	36	845	7,46
Diesel Fuel	1159	39	830	7,60
Fuel oil 80 CST	1065	42	816	7,73
Fuel oil 180 CST	1050	50	780	8,06
Fuel oil 230 CST	1047			
Fuel oil 280 CST	1044			
Bitumen	979			

7 Acronyms

Acronym	Description
AC	Alternating Current
AGA	American Gas Association
API	American Petroleum Institute
CCR	Central Control Room
CMS	Condition Monitoring Systems
CSP	Collector and Separation Platform
DC	Direct Current
DYNPOS	Dynamic positioning (of rigs and ships)
E&P	Exploration and Production
EOR	Enhanced Oil Recovery
ESD	Emergency ShutDown system
ESP	Electric Submerged Pump
F&G	Fire & Gas System
FPSO	Floating Production Storage and Offloading
GB(S)	Gravity Base Structure
GOR	Gas Oil Ratio from the well
GOSP	Gas Oil Separation Plant
GTP	Gas Treatment Platform
HP	High Pressure
HPU	Hydraulic Power Unit (topside utility for subsea)
HVAC	Heat Ventilation and Air Conditioning
IR	Infra Red
ISO	International Standards Organization
K-Mass Flow	Coriolis type Mass Flow meter
LNG	Liquid Natural Gas (e.g. Methane)
LP	Low Pressure
LPG	Liquified Petroleum Gas (e.g. Propane)
MCC	Motor Control Centre
MTBF	Mean Time Between Failure
NGL	Natural Gas Liquids, Condensates see also LPG
PCP	Progressive Cavity Pump
PD-Meter	Positive Displacement meter
PGP	Power Generation Platform
PID	Proportional Integral Derivate control algorithm
PIMS	Production Information Management System
PoC	Pimp of controller (for artificial lift)
POSMOR	Position mooring for a floating facility
PSD	Process Shutdown System
ROV	Remote Operated Vehicle (for subsea workover)
RTU	Remote Terminal Unit

SAS	Safety and Automation System
SCADA	Supervisory Control And Data Acquisition
TIP	Tie-In Platform
TLP	Tension Leg Platform
UMS	Unmanned Machinery Space classification (marine = E0)
URF	Umbilicals, Risers and Flowlines
UV	Ultra Violet
WHP	Well Head Platform

8 References

Web on line sources and references that has been used in compiling this document:

- Schlumberger oilfield glossary:
<http://www.glossary.oilfield.slb.com/default.cfm>
- Norsk Hydro, Njord Main Process and Oil Process Description.
http://www.hydro.com/en/our_business/oil_energy/production/oil_gas_norway/njord.html
- Wikipedia http://en.wikipedia.org/wiki/Main_Page
- Oklahoma State, Marginal Well Commission, Pumper's Manual
http://www.marginalwells.com/MWC/pumper_manual.htm
- Natural Gas Supply Association. See Natural Gas - From Wellhead to Burner Tip
<http://www.naturalgas.org/index.asp>
- US geological survey: <http://www.usgs.gov/>
- US department of energy: <http://www.doe.gov/>
- NORSOK standards, Standards Norway (SN),
<http://www.standard.no/imaker.exe?id=244>
- UK Offshore Operators Association (UKOOA)
<http://www.oilandgas.org.uk/issues/storyofoil/index.htm>
- National Biodiesel Board <http://www.biodiesel.org/>
- PBS – Public Broadcasting Service - Extreme Oil
<http://www.pbs.org/wnet/extremeoil/index.html>
- <http://www.priweb.org/ed/pgws/history/pennsylvania/pennsylvania.html>

