



OFFSHORE STANDARD

DNV-OS-F101

Submarine Pipeline Systems

AUGUST 2012

The electronic pdf version of this document found through <http://www.dnv.com> is the officially binding version

FOREWORD

DET NORSKE VERITAS (DNV) is an autonomous and independent foundation with the objectives of safeguarding life, property and the environment, at sea and onshore. DNV undertakes classification, certification, and other verification and consultancy services relating to quality of ships, offshore units and installations, and onshore industries worldwide, and carries out research in relation to these functions.

DNV service documents consist of among others the following types of documents:

- *Service Specifications*. Procedural requirements.
- *Standards*. Technical requirements.
- *Recommended Practices*. Guidance.

The Standards and Recommended Practices are offered within the following areas:

- A) Qualification, Quality and Safety Methodology
- B) Materials Technology
- C) Structures
- D) Systems
- E) Special Facilities
- F) Pipelines and Risers
- G) Asset Operation
- H) Marine Operations
- J) Cleaner Energy
- O) Subsea Systems

© Det Norske Veritas AS August 2012

Any comments may be sent by e-mail to rules@dnv.com

This service document has been prepared based on available knowledge, technology and/or information at the time of issuance of this document, and is believed to reflect the best of contemporary technology. The use of this document by others than DNV is at the user's sole risk. DNV does not accept any liability or responsibility for loss or damages resulting from any use of this document.

CHANGES

General

This document supersedes DNV-OS-F101, October 2010.

Text affected by the main changes in this edition is highlighted in red colour. However, if the changes involve a whole chapter, section or sub-section, normally only the title will be in red colour.

Main Changes

- **Sec.1 General**

- Minor editorial changes and updates
- B: Reference list updated
- Introduction included. Previous A600 moved to B100
- C: Updated definitions.

- **Sec.2 Safety Philosophy**

- Minor editorial changes and updates
- Clarification of acceptance target values
- B: The general requirements to a systematic review, B300, has been further implemented as a new A300 in sections 3 to 11
- C201: CO₂ pipelines commented, recommended deviation from ISO.

- **Sec.3 Concept and Design Premise Development**

- Re-organised in a timeline manner
- Minor editorial changes and updates
- D200: Pressure protection system (including pressure safety system and pressure control system) has been renamed as pipeline control and pipeline safety system in line with IEC 61511.

- **Sec.4 Design – Loads**

- Minor editorial changes and updates
- C600: Weather restricted weather operations aligned with DNV-OS-H101.

- **Sec.5 Design – Limit State Criteria**

- Minor editorial changes and updates
- D200: Pressure containment limit stated; influence of mill test and system test clarified
- D1300: Dent added as limit state (moved from trawling)
- E: Special considerations; levels of details are aligned between the different sub-sections
- E800: Requirements to earth quake extended
- F: Component design updated reflecting revisions of ISO and further aligned with section 8
- F100: Advice for code breaks included.

- **Sec.6 Design – Materials Engineering**

- Minor editorial changes and updates.

- **Sec.7 Construction – Linepipe**

- Updated to reflect new ISO 3183 revision
- General update based on feed-back from industry
- G200: Criteria to dimensional tolerances clarified.

- **Sec.8 Construction - Components and Pipeline Assemblies**

- Re-structured to improve clarity
- B300 to 500: Updated to reflect new ISO 15590 revision
- C500: Section on bolts updated
- F: Section on pipeline assemblies partly re-written.

- **Sec.9 Construction – Corrosion protection and Weight Coating**

- Re-written to align with ISO 21809

- **Sec.10 Construction - Offshore**

- Section heading changed to reflect contents
- Completely re-structured and modified.

- **Sec.11 Operations and Abandonment**
 - Updated to reflect alignment with DNV-RP-F116.
- **Sec.12 Documentation**
 - Minor changes
- **App.A Fracture Limit State of Girth Welds**
 - B107: Rules for how different load cases shall be combined have been included
 - D: Fracture toughness testing on SENT specimens also acceptable for bi-axial stress condition (operation)
 - D: New definition of L_r cut-off (plastic collapse) which will allow higher local stresses and strains in the ligament with a flaw
 - E: Use of FE analysis amended
 - F: No safety factor on the calculated fatigue life.
- **App.B Mechanical Testing and Corrosion Testing**
 - General update based on feed-back from industry and clarifications.
- **App.C Welding**
 - General update based on feed-back from industry
 - More precise definitions added to make several of the requirements clearer
 - C300 and F300: Changes to requirement of weld filler metal yield strength.
- **App.D Non-Destructive Testing (NDT)**
 - Referenced standards updated. Withdrawn referenced standards replaced with new standards
 - Aligned requirements for MT and PT with other international accepted standards
 - B200: References for computed radiography implemented
 - B300: References to DNV Classification Note 7 implemented.
- **App.E Automated Ultrasonic Girth Weld Testing**
 - General update based on feed-back from industry and clarifications
 - DNV-RP-F118 implemented as reference for qualification of AUT systems
 - Requirements in DNV-OS-F101 is aligned with requirements in DNV-RP-F118.
- **App.F Requirements for Shore Approach and Onshore Sections**
 - Minor changes.

Acknowledgement

The present revision of DNV-OS-F101 is mainly reflecting feed-back from experience by several companies that are hereby acknowledged.

This revision includes a re-structuring of Section 10 “Offshore – construction” based on close valuable discussions from Statoil, hereby acknowledged.

A hearing version was issued December 2011. Close to 1000 very well founded comments were received of which most were either accepted or partly accepted. Many of the comments not accepted were typically requesting extension of the scope, e.g. parameter limitations, requiring further developments. Those comments have been noted as leads and may result in future Joint Industry proposals.

The comments improved the quality and content of this standard significantly and the effort spent by the commenting companies is impressive and hereby acknowledged. The commenting companies were (in alphabetical order):

AG der Dillinger Huttenwerke	JDP	Saipem
Allseas	JFE-steel	Statoil
BP	Mærsk	Subsea 7
Chevron ETC	Nippon Steel	Tata Steel
Europipe	Nordstream	Technip
ExxonMobil	Petrobras	Total
Heerema Marine Contractors	Reinertsen	Woodside

CONTENTS

Sec. 1	General	17
A.	General	17
A 100	Introduction	17
A 200	Objectives	17
A 300	Scope and application	17
A 400	Alternative methods and procedures	18
A 500	Structure of standard	18
B.	References	19
B 100	Applicability	19
B 200	Offshore service specifications	20
B 300	Offshore standards	20
B 400	Recommended practices	20
B 500	Rules	21
B 600	Certification notes and classification notes	21
B 700	Other references	21
C.	Definitions	25
C 100	Verbal forms	25
C 200	Definitions	25
C 300	Definitions (continued)	29
D.	Abbreviations and Symbols	33
D 100	Abbreviations	33
D 200	Symbols – latin characters	35
D 300	Symbols – greek characters	37
D 400	Subscripts	38
Sec. 2	Safety Philosophy	39
A.	General	39
A 100	Objective	39
A 200	Application	39
B.	Safety Philosophy Structure	39
B 100	General	39
B 200	Safety objective	39
B 300	Systematic review of risks	40
B 400	Design criteria principles	41
B 500	Quality assurance	41
B 600	Health, safety and environment	41
C.	Risk Basis for Design	41
C 100	General	41
C 200	Categorisation of fluids	41
C 300	Location classes	42
C 400	Safety classes	42
C 500	Reliability analysis	43
Sec. 3	Concept and Design Premise Development	44
A.	General	44
A 100	Objective	44
A 200	Application	44
A 300	Systematic review	44
B.	Concept Development	44
B 100	Concept development	44
C.	Design Premise	45
C 100	Hydraulic analyses and flow assurance	45
C 200	Environmental condition	46
C 300	Collection of environmental data	46
C 400	Environmental data	46
C 500	Pipeline route	46
C 600	Route survey	47
C 700	Seabed properties	48
D.	System Design Principles	49
D 100	System integrity	49
D 200	Pipeline control and safety system	49

D 300	External corrosion control.....	51
D 400	Internal construction conditions.....	51
D 500	Internal corrosion control.....	51
Sec. 4	Design - Loads.....	52
A.	General.....	52
A 100	Objective.....	52
A 200	Application.....	52
A 300	Systematic review.....	52
A 400	Load scenarios.....	52
A 500	Categorisation of loads.....	52
A 600	Design load effects.....	52
B.	Functional Loads.....	52
B 100	General.....	52
B 200	Internal pressure loads.....	53
C.	Environmental Loads.....	54
C 100	General.....	54
C 200	Wind loads.....	54
C 300	Hydrodynamic loads.....	54
C 400	Ice loads.....	56
C 500	Earthquake.....	56
C 600	Characteristic environmental load effects.....	56
D.	Construction Loads.....	58
D 100	General.....	58
E.	Interference Loads.....	59
E 100	General.....	59
F.	Accidental Loads.....	59
F 100	General.....	59
G.	Design Load Effects.....	59
G 100	General.....	59
G 200	Characteristic load.....	59
G 300	Design load effect.....	60
G 400	Load effect calculations.....	61
Sec. 5	Design – Limit State Criteria.....	63
A.	General.....	63
A 100	Objective.....	63
A 200	Application.....	63
A 300	Systematic review.....	63
B.	System Design Requirements.....	63
B 100	Submarine pipeline system layout.....	63
B 200	Pressure test philosophy and criteria.....	65
B 300	Monitoring/inspection during operation.....	66
C.	Design Format.....	67
C 100	General.....	67
C 200	Design resistance.....	67
C 300	Characteristic material properties.....	68
C 400	Characteristic wall thickness.....	70
C 500	Stress and strain calculations.....	70
D.	Limit States.....	71
D 100	General.....	71
D 200	Pressure containment (bursting).....	72
D 300	Local buckling - general.....	72
D 400	Local Buckling – external over pressure only (system collapse).....	72
D 500	Propagation buckling.....	73
D 600	Local buckling - combined loading criteria.....	74
D 700	Global buckling.....	77
D 800	Fatigue.....	77
D 900	Fracture, supplementary requirement P and F and HISC.....	79
D 1000	Ultimate limit state – accidental loads.....	80
D 1100	Ovalisation.....	80
D 1200	Accumulated deformation.....	81
D 1300	Dent.....	81

E. Special Considerations	81
E 100 General.....	81
E 200 Pipe soil interaction	81
E 300 Global buckling.....	82
E 400 Free spanning pipelines and risers.....	82
E 500 On bottom stability.....	82
E 600 Trawling interference.....	83
E 700 Third party loads, dropped objects.....	83
E 800 Earth quakes.....	84
E 900 Thermal insulation.....	84
E 1000 Settings from plugs.....	84
F. Pipeline Components	84
F 100 General.....	84
F 200 Induction bends.....	86
F 300 Fittings.....	87
F 400 Valves.....	87
F 500 Insulating joints.....	87
F 600 Pig traps.....	88
G. Supporting Structure	88
G 100 General.....	88
G 200 Pipe-in-pipe and bundles	88
G 300 Riser supports	88
G 400 J-tubes.....	88
G 500 Stability of gravel supports and gravel covers.....	89
H. Installation and Repair	89
H 100 General.....	89
H 200 Pipe straightness	90
H 300 Weight coating.....	90
Sec. 6 Design - Materials Engineering.....	91
A. General.....	91
A 100 Objective.....	91
A 200 Application.....	91
A 300 Systematic review.....	91
A 400 Documentation.....	91
B. Materials Selection for Linepipe and Pipeline Components.....	92
B 100 General.....	92
B 200 H ₂ S service	92
B 300 Corrosion resistant alloys (informative).....	92
B 400 Linepipe (informative).....	93
B 500 Pipeline components (informative).....	94
B 600 Bolts and nuts.....	94
B 700 Welding consumables (informative).....	95
C. Materials Specification	95
C 100 General.....	95
C 200 Linepipe specification.....	95
C 300 Components specification	96
C 400 Specification of bolts and nuts.....	97
C 500 Coating specification.....	97
C 600 Galvanic anode specification.....	97
C 700 Concrete coating specification.....	97
D. Corrosion Control	98
D 100 General.....	98
D 200 Corrosion allowance	98
D 300 Temporary corrosion protection	98
D 400 External pipeline coatings (informative)	99
D 500 Cathodic protection.....	100
D 600 External corrosion control of risers (informative).....	101
D 700 Internal corrosion control (informative)	102
Sec. 7 Construction – Linepipe	104
A. General.....	104
A 100 Objective.....	104
A 200 Application.....	104
A 300 Systematic review.....	104
A 400 Process of manufacture.....	104
A 500 Supplementary requirements	105

A 600	Linepipe specification	105
A 700	Manufacturing procedure specification	105
A 800	Manufacturing procedure qualification test	106
B.	Carbon Manganese (C-Mn) Steel Linepipe	107
B 100	General	107
B 200	Pipe designation	107
B 300	Manufacturing	107
B 400	Acceptance criteria	110
B 500	Inspection	114
C.	Corrosion Resistant Alloy (CRA) Linepipe	117
C 100	General	117
C 200	Pipe designation	117
C 300	Manufacturing	118
C 400	Acceptance criteria	118
C 500	Inspection	119
D.	Clad or Lined Steel Linepipe	121
D 100	General	121
D 200	Pipe designation	121
D 300	Manufacturing procedure specification	121
D 400	Manufacturing	122
D 500	Acceptance criteria	123
D 600	Inspection	123
E.	Hydrostatic Testing	125
E 100	Mill pressure test	125
F.	Non-destructive Testing	126
F 100	Visual inspection	126
F 200	Non-destructive testing	126
G.	Dimensions, Mass and Tolerances	127
G 100	General	127
G 200	Tolerances	128
G 300	Inspection	128
H.	Marking, Delivery Condition and Documentation	131
H 100	Marking	131
H 200	Delivery condition	131
H 300	Handling and storage	131
H 400	Documentation, records and certification	131
I.	Supplementary Requirements	131
I 100	Supplementary requirement, H2S service (S)	131
I 200	Supplementary requirement, fracture arrest properties (F)	134
I 300	Supplementary requirement, linepipe for plastic deformation (P)	135
I 400	Supplementary requirement, dimensions (D)	136
I 500	Supplementary requirement, high utilisation (U)	137
Sec. 8	Construction - Components and Pipeline Assemblies	139
A.	General	139
A 100	Objective	139
A 200	Application	139
A 300	Systematic review	139
A 400	Quality assurance	139
B.	Component Requirements	139
B 100	General	139
B 200	Component specification	140
B 300	Induction bends – additional and modified requirements to ISO 15590-1	140
B 400	Fittings - additional requirements to ISO 15590-2	141
B 500	Flanges and flanged connections - additional requirements to ISO 15590-3	143
B 600	Valves – additional requirements to ISO 14723	144
B 700	Mechanical connectors	145
B 800	CP Isolation joints	145
B 900	Anchor flanges	147
B 1000	Buckle- and fracture arrestors	147
B 1100	Pig traps	147
B 1200	Repair clamps and repair couplings	147
C.	Materials	147
C 100	General	147
C 200	C-Mn and low alloy steel forgings and castings	148

C 300	Duplex stainless steel, forgings and castings	148
C 400	Pipe and plate material	148
C 500	Bolting materials	148
C 600	H ₂ S service	149
D.	Manufacture	149
D 100	Manufacturing procedure specification (MPS)	149
D 200	Forging	150
D 300	Casting	150
D 400	Hot forming	150
D 500	Heat treatment	151
D 600	Welding	151
D 700	NDT	151
E.	Mechanical and Corrosion Testing	152
E 100	General testing requirements	152
E 200	Acceptance criteria for C-Mn and low alloy steels	152
E 300	Acceptance criteria for duplex stainless steels	153
F.	Pipeline Assemblies	153
F 100	General	153
F 200	Materials	154
F 300	Fabrication procedures, planning and mobilisation	154
F 400	Linepipe temporary storage and transportation	154
F 500	Material receipt, identification and tracking	155
F 600	Hydrostatic testing	155
F 700	Welding and NDT	155
F 800	Cutting, forming and heat treatment	156
F 900	Verification of dimensions and weight	156
F 1000	Corrosion protection and thermal insulation	156
G.	Hydrostatic Testing	156
G 100	Hydrostatic testing	156
G 200	Alternative test pressures	157
H.	Documentation, Records, Certification and Marking	157
H 100	General	157
Sec. 9	Construction - Corrosion Protection and Weight Coating	159
A.	General	159
A 100	Objective	159
A 200	Application	159
A 300	Systematic review	159
B.	External Corrosion Protective Coatings	159
B 100	General	159
B 200	Coating materials, surface preparation, coating application and inspection/testing of coating	160
C.	Concrete Weight Coating	160
C 100	General	160
C 200	Materials	161
C 300	Concrete mix	161
C 400	Coating application	161
C 500	Inspection and testing	162
D.	Manufacture of Galvanic Anodes	162
D 100	Anode manufacture	162
E.	Installation of Galvanic Anodes	163
E 100	Anode installation	163
Sec. 10	Construction – Offshore	164
A.	General	164
A 100	Objective	164
A 200	Application	164
A 300	Systematic review	164
A 400	Installation manual	164
A 500	Quality assurance	164
B.	Pipe assemblies onshore	165
B 100	Pipe assemblies onshore	165
C.	Pipeline Route, Pre-installation Survey and Preparation	165
C 100	Pre-installation route survey	165

C 200	Seabed preparation including shore approaches	165
C 300	Existing pipelines and cables including crossings	166
D.	Installation Spread	166
D 100	General	166
D 200	Vessels	166
D 300	Positioning systems	167
D 400	Anchoring systems, anchor patterns and anchor handling	167
D 500	Dynamic positioning	168
D 600	Cranes and lifting equipment	169
D 700	Layvessel arrangement, laying equipment and instrumentation	169
D 800	Mobilization	171
D 900	Qualification of vessel and equipment	171
D 1000	General calibration and testing	171
D 1100	Calibration and testing frequency	172
E.	Welding and Non-destructive Testing	172
E 100	General	172
E 200	Welding	172
E 300	Non-destructive testing	173
F.	Pipeline Installation	173
F 100	General	173
F 200	Additional requirements for installation method S-Lay	175
F 300	Additional requirements for installation method J-Lay	175
F 400	Additional requirements for installation methods introducing significant plastic strains	175
F 500	Towing	175
F 600	J-tube pull-in of risers	175
F 700	Shore pull	176
F 800	Buckle detection	176
F 900	Operating limit conditions	177
F 1000	Spools and other in-line assemblies installed separately from pipeline	177
G.	Post-lay Survey	177
G 100	General	177
G 200	Survey requirements	178
G 300	Survey of corrosion protection systems	178
H.	Post-lay intervention (Seabed intervention and Pipeline Protection)	179
H 100	General	179
H 200	Span rectification and protection specification	179
H 300	Free span rectification	179
H 400	Trenching	179
H 500	Post-installation gravel installation	180
H 600	Grout bags and concrete mattresses	180
I.	Tie-in	180
I 100	General	180
I 200	Tie-in operations above water	181
I 300	Tie-in operations below water	181
J.	Pre-commissioning	181
J 100	General	181
J 200	Waterfilling, cleaning and gauging	181
J 300	System pressure testing	182
J 400	De-watering and drying	184
J 500	Systems testing	184
K.	Documentation	184
K 100	General	184
L.	Installation manual	184
L 100	Installation manual	184
L 200	Installation procedures	186
L 300	Pre-commissioning procedures	186
L 400	Contingency procedures	186
Sec. 11	Operations and Abandonment	188
A.	General	188
A 100	Objective	188
A 200	Scope and application	188
A 300	Systematic review of risks	188
A 400	Responsibilities	188
A 500	Authority and pipeline operator requirements	189

A 600	Safety philosophy	189
B.	Commissioning	189
B 100	General	189
B 200	Fluid filling	189
B 300	Operational verification	189
C.	Integrity Management System	190
C 100	General	190
C 200	Pipeline operator policy	190
C 300	Organisation and personnel	190
C 400	Management of change	190
C 500	Operational controls and procedures	190
C 600	Contingency plans	191
C 700	Reporting and communication	191
C 800	Audit and review	191
C 900	Information management	191
D.	Integrity Management Process	191
D 100	General	191
D 200	Risk assessment and integrity management planning - evaluation of threats and condition	192
D 300	Inspection, monitoring and testing	192
D 400	Integrity assessment	195
D 500	Mitigation, intervention and repairs	195
E.	Re-qualification	196
E 100	General	196
E 200	Application	197
E 300	Safety level	197
E 400	System pressure test	197
E 500	Deterioration	197
E 600	Design criteria	198
F.	De-commissioning	198
F 100	General	198
G.	Abandonment	198
G 100	General	198
Sec. 12	Documentation	199
A.	General	199
A 100	Objective	199
B.	Design	199
B 100	Structural	199
B 200	Linepipe and pipeline components (including welding)	200
B 300	Corrosion control systems and weight coating	200
B 400	Installation	200
B 500	Operation	200
B 600	DFI-Resumé	201
C.	Construction - Manufacturing and Fabrication	201
C 100	Linepipe and pipeline component	201
C 200	Corrosion control system and weight coating	201
C 300	DFI-resumé	202
D.	Construction - Installation and Pre-Commissioning	202
D 100	General	202
D 200	DFI-Resumé	202
E.	Operation - Commissioning	202
E 100	General	202
F.	Operation	203
F 100	General	203
F 200	In-Service file	203
G.	Abandonment	203
G 100	General	203
H.	DFI Resumé	203
H 100	General	203
H 200	DFI resumé content	204
I.	Filing of Documentation	205
I 100	General	205

Sec. 13 Commentary (Informative)	206
A. General	206
A 100 Objective	206
B. Safety and Design Philosophy	206
B 100 Safety class discussion	206
B 200 Structural reliability analyses	206
B 300 Characteristic values	207
C. Loads	207
C 100 Conversion of pressures	207
D. Design Criteria	207
D 100 General	207
D 200 Condition load effect factors	208
D 300 Calculation of nominal thickness	208
D 400 Pressure containment - equivalent format	208
D 500 Pressure containment criterion, design pressure less than 10% below the incidental pressure	209
D 600 HIPPS and similar systems	209
D 700 Local buckling - collapse	210
D 800 Buckle arrestor	211
D 900 Local buckling - moment	211
D 1000 Local buckling - girth weld factor	211
D 1100 Ovalisation	211
E. API Material Grades	212
E 100 API material grades	212
F. Pipe-in-pipe and bundles	212
F 100 Pipe-in-pipe and bundles – general	212
F 200 Design load effects and design limit states	212
F 300 Construction – manufacture	213
F 400 Construction – offshore	213
F 500 Operation	213
G. Installation	214
G 100 Safety class definition	214
G 200 Coating	214
G 300 Simplified laying criteria	214
H. References	215
App. A Fracture Limit State of Girth Welds	216
A. General	216
A 100 Introduction	216
A 200 Objective	216
A 300 Application	217
A 400 Fracture toughness	217
A 500 References	218
B. Assessment Categories	218
B 100 General	218
C. Generic ECA for Girth Welds subjected to Strains Less than 2.25% Assessed According to ECA Static	220
C 100 General	220
D. Girth Welds under Strain-based Loading Assessed According to ECA Static - Full	223
D 100 General	223
D 200 Assessment methodology	225
E. Use of Finite Element (FE) Fracture Mechanics Analyses to Assess Maximum Allowable Flaw Sizes	229
E 100 General	229
E 200 FE model	229
F. Girth Welds Assessed According to ECA Fatigue	230
F 100 General	230
F 200 Low-cycle fatigue	231
G. Testing Requirements	231
G 100 General	231
G 200 Straining and ageing	233
H. ECA Validation Testing	235
H 100 General	235

App. B Mechanical Testing and Corrosion Testing	236
A. General.....	236
A 100 Objective.....	236
A 200 Applicability.....	236
A 300 References.....	236
B. Mechanical Testing and Chemical Analysis.....	237
B 100 General requirements to selection and preparation of samples and test pieces.....	237
B 200 Chemical analysis.....	237
B 300 Tensile testing.....	237
B 400 Charpy V-notch impact testing.....	239
B 500 Bend testing.....	239
B 600 Flattening test.....	240
B 700 Drop weight tear test.....	240
B 800 Fracture toughness testing.....	241
B 900 Specific tests for clad and lined linepipe.....	243
B 1000 Metallographic examination and hardness testing.....	243
B 1100 Straining and ageing.....	244
B 1200 Testing of pin brazings and aluminothermic welds.....	244
C. Corrosion Testing.....	245
C 100 General.....	245
C 200 Pitting corrosion test.....	245
C 300 Hydrogen induced cracking test.....	245
C 400 Sulphide stress cracking test.....	245
App. C Welding	251
A. General.....	251
A 100 Objective.....	251
A 200 Application.....	251
A 300 Definitions.....	251
A 400 Quality assurance.....	252
B. Welding Equipment, Tools and Personnel.....	252
B 100 Welding equipment and tools.....	252
B 200 Personnel.....	252
B 300 Qualification and testing of welding personnel for hyperbaric dry welding.....	253
C. Welding Consumables.....	253
C 100 General.....	253
C 200 Chemical composition.....	254
C 300 Mechanical properties.....	254
C 400 Batch testing of welding consumables for pipeline girth welds.....	255
C 500 Shielding, backing and plasma gases.....	256
C 600 Handling and storage of welding consumables.....	256
D. Welding Procedures.....	256
D 100 General.....	256
D 200 Previously qualified welding procedures.....	256
D 300 Preliminary welding procedure specification.....	257
D 400 Welding procedure qualification record.....	257
D 500 Welding procedure specification.....	257
D 600 Welding procedure specification for repair welding.....	257
D 700 Contents of pWPS.....	257
D 800 Essential variables for welding procedures.....	258
E. Qualification of Welding Procedures.....	262
E 100 General.....	262
E 200 Repair welding procedures.....	263
E 300 Qualification of girth butt welds and component longitudinal welds welding procedures.....	264
E 400 Qualification of welding procedures for corrosion resistant overlay welding.....	265
E 500 Qualification of procedures for Pin Brazing and Aluminothermic welding of anode leads.....	266
E 600 Qualification of welding procedures for temporary and permanent attachments and branch welding fittings to linepipe.....	266
E 700 Qualification of welding procedures for structural components.....	267
E 800 Qualification of welding procedures for hyperbaric dry welding.....	267
F. Examination and Testing for Welding Procedure Qualification.....	267
F 100 General.....	267
F 200 Visual examination and non-destructive testing requirements.....	269
F 300 Testing of butt welds.....	269
F 400 Testing of weld overlay.....	271
F 500 Testing of pin brazing and aluminothermic welds.....	272

F 600	Testing of welds for temporary and permanent attachments and branch outlet fittings to linepipe.....	272
G.	Welding and PWHT Requirements.....	272
G 100	General.....	272
G 200	Production welding, general requirements	272
G 300	Repair welding, general requirements	274
G 400	Post weld heat treatment	275
G 500	Welding of pipeline girth welds.....	275
G 600	Welding and PWHT of pipeline components	277
H.	Material and Process Specific Requirements.....	277
H 100	Internally clad/lined carbon steel and duplex stainless steel	277
H 200	13Cr Martensitic stainless steel	279
H 300	Pin brazing and aluminothermic welding	279
I.	Hyperbaric Dry Welding.....	280
I 100	General.....	280
I 200	Qualification and testing of welding personnel for hyperbaric dry welding	280
I 300	Welding processes for hyperbaric dry welding	281
I 400	Welding consumables for hyperbaric dry welding.....	281
I 500	Shielding and backing gases for hyperbaric dry welding.....	281
I 600	Welding equipment and systems for hyperbaric dry welding	282
I 700	Welding procedures for hyperbaric dry welding	282
I 800	Qualification welding for hyperbaric dry welding.....	283
I 900	Qualification of welding procedures for hyperbaric dry welding.....	283
I 1000	Examination and testing.....	283
I 1100	Production welding requirements for dry hyperbaric welding.....	283
App. D	Non-Destructive Testing (NDT).....	285
A.	General.....	285
A 100	Objective.....	285
A 200	Applicability of requirements	285
A 300	Quality assurance.....	285
A 400	Non-destructive testing methods	285
A 500	Personnel qualifications	286
A 600	Timing of NDT	286
B.	Manual Non-Destructive Testing and Visual Examination of Welds.....	286
B 100	General.....	286
B 200	Radiographic testing of welds.....	287
B 300	Manual ultrasonic testing of welds in C-Mn/low alloy steel with C-Mn/low alloy steel weld deposits	289
B 400	Manual ultrasonic testing of welds with CRA (duplex, other stainless steels and nickel alloy steel) weld deposits.....	293
B 500	Manual magnetic particle testing of welds	295
B 600	Manual liquid penetrant testing of welds.....	296
B 700	Manual eddy current testing of welds.....	296
B 800	Visual examination of welds.....	297
B 900	Acceptance criteria for manual non-destructive testing of welds with nominal strains < 0.4% and no ECA..	297
B 1000	ECA based non-destructive testing acceptance criteria for pipeline girth welds.....	298
B 1100	Repair of welds	302
C.	Manual Non-destructive testing and Visual Examination of Plate, Pipe and Weld Overlay.....	302
C 100	General.....	302
C 200	Plate and pipe.....	303
C 300	Weld overlay.....	304
C 400	Visual examination	305
C 500	Residual magnetism.....	305
C 600	Acceptance criteria for manual non-destructive testing of plate, pipe and weld overlay	305
D.	Non-destructive Testing and Visual Examination of Forgings.....	306
D 100	General.....	306
D 200	Ultrasonic and magnetic particle testing of C-Mn and low alloy steel forgings	306
D 300	Ultrasonic and liquid penetrant testing of duplex stainless steel forgings.....	308
D 400	Visual examination of forgings.....	309
D 500	Acceptance criteria for forgings.....	309
E.	Non-destructive Testing and Visual Examination of Castings	310
E 100	General.....	310
E 200	Ultrasonic and magnetic particle testing of C-Mn and low alloy steel castings.....	310
E 300	Ultrasonic and liquid penetrant testing of duplex stainless steel castings	311
E 400	Radiographic testing of castings	312
E 500	Visual examination of castings.....	312
E 600	Acceptance criteria for castings.....	312

F. Automated Non-Destructive Testing	313
F 100 General.....	313
F 200 Documentation of function and operation	314
F 300 Documentation of performance	314
F 400 Qualification	314
F 500 Evaluation of performance documentation.....	314
G. Non-Destructive Testing at Plate and Coil Mill.....	314
G 100 General.....	314
G 200 Ultrasonic testing of C-Mn steel and CRA plates.....	315
G 300 Ultrasonic testing of CRA clad C-Mn steel plate	316
G 400 Alternative test methods	316
G 500 Disposition of plate and coil with unacceptable laminations or inclusions	316
G 600 Visual examination of plate and coil	316
G 700 Acceptance criteria and disposition of surface imperfections	317
H. Non-Destructive Testing of Linepipe at Pipe Mills	317
H 100 General.....	317
H 200 Suspect pipe	318
H 300 Repair of suspect pipe.....	318
H 400 General requirements for automated NDT systems.....	319
H 500 Visual examination and residual magnetism	321
H 600 Non-destructive testing of pipe ends not tested by automated NDT equipment	324
H 700 Non-destructive testing of pipe ends.....	324
H 800 Non-destructive testing of seamless pipe.....	325
H 900 Non-destructive testing of HFW pipe	326
H 1000 Non-destructive testing of CRA liner pipe	327
H 1100 Non-destructive testing of lined pipe.....	327
H 1200 Non-destructive testing of clad pipe	328
H 1300 Non-destructive testing of SAWL and SAWH pipe	330
H 1400 Manual NDT at pipe mills	333
H 1500 Non-destructive testing of weld repair in pipe	336
App. E Automated Ultrasonic Girth Weld Testing.....	337
A. General	337
A 100 Objective.....	337
A 200 Applicability	337
A 300 References.....	337
B. Basic Requirements.....	337
B 100 General.....	337
B 200 Documentation.....	338
B 300 Scope of qualification	339
B 400 Ultrasonic system equipment and components.....	339
B 500 Calibration (reference) blocks.....	340
B 600 Recorder set-up	341
B 700 Circumferential scanning velocity.....	341
B 800 Power supply.....	341
B 900 Software	342
B 1000 Reference line, band position and coating cut-back	342
B 1100 Reference line tools.....	342
B 1200 Operators.....	342
B 1300 Spares.....	342
B 1400 Slave monitors	343
C. Procedure	343
C 100 General.....	343
D. Calibration (Sensitivity Setting).....	343
D 100 Initial static calibration	343
D 200 Gate settings.....	344
D 300 Recording threshold	344
D 400 Dynamic calibration.....	345
D 500 Recording of set-up data	345
E. Field Inspection.....	345
E 100 Inspection requirements.....	345
E 200 Operational checks.....	347
E 300 Adjustments of the AUT system.....	347
E 400 Acceptance criteria.....	348
F. Re-examination of Welds.....	349
F 100 General.....	349

G. Evaluation and Reporting.....	349
G 100 Evaluation of indications	349
G 200 Examination reports	349
G 300 Inspection records	349
H. Qualification.....	350
H 100 General.....	350
H 200 Scope.....	350
H 300 Requirements	350
H 400 Variables	350
H 500 Qualification programme	351
H 600 Test welds	351
H 700 Qualification testing	353
H 800 Reference destructive testing	355
H 900 Analysis	355
H 1000 Reporting	356
I. Project Specific AUT Procedure Validation	356
I 100 Scope.....	356
I 200 Assessment.....	356
J. Validity of Qualification	357
J 100 Validity	357
J 200 Essential variables.....	357
K. Determination of Wave Velocities in Pipe Steels.....	358
K 100 General.....	358
K 200 Equipment.....	358
K 300 Specimens	358
K 400 Test method.....	358
K 500 Accuracy	359
K 600 Recording.....	359
App. F Requirements for Shore Approach and Onshore Sections.....	360
A. Application.....	360
A 100 Objective.....	360
A 200 Scope and limitation	360
A 300 Other codes	360
A 400 Definitions	361
B. Safety Philosophy	361
B 100 General.....	361
B 200 Safety philosophy	362
B 300 Quantification of consequence	362
C. Design Premise	363
C 100 General.....	363
C 200 Routing.....	363
C 300 Environmental data	364
C 400 Survey	364
C 500 Marking.....	364
D. Design	365
D 100 General.....	365
D 200 System design	365
D 300 Design loads.....	365
D 400 Design criteria.....	365
E. Construction.....	366
E 100 General.....	366
E 200 Linepipe	366
E 300 Components and assemblies	366
E 400 Corrosion protection and coatings	367
F. Operation.....	367
F 100 General.....	367
G. Documentation	367
G 100 General.....	367

SECTION 1 GENERAL

A. General

A 100 Introduction

101 This standard gives criteria and recommendations on concept development, design, construction, operation and abandonment of Submarine Pipeline Systems.

A 200 Objectives

201 The objectives of this standard are to:

- ensure that the concept development, design, construction, operation and abandonment of pipeline systems are safe and conducted with due regard to public safety and the protection of the environment
- provide an internationally acceptable standard of safety for submarine pipeline systems by defining minimum requirements for concept development, design, construction, operation and abandonment
- serve as a technical reference document in contractual matters between Purchaser and Contractor
- serve as a guideline for Designers, Purchaser, and Contractors.

A 300 Scope and application

301 The scope and applicability of this standard is given in Table 1-1.

Table 1-1 Scope and application summary	
<i>General</i>	
	Systems in the petroleum and natural gas industries are in general described in this table. For submarine pipeline systems that have extraordinary consequences, the quantification of consequences by the three safety classes provided in this standard may be insufficient, and higher safety classes may be required. ¹
<i>Phases</i>	Concept development, design, construction, operation and abandonment
<i>Pipeline Types</i>	Single rigid metallic pipe systems, pipeline bundles of the piggyback type and pipeline bundles within an outer pipe ²
	Pipe-in-pipe
	<i>Dynamic risers</i> and compliant risers are covered by DNV-OS-F201 <i>Dynamic Risers</i> .
<i>Extent</i>	
Pressure and flow	<i>Pipeline system</i> in such a way that the fluid transportation and pressure in the submarine pipeline system is well defined and controlled ³
Concept development, design, construction, operation and abandonment	<i>Submarine pipeline system</i> ⁴
<i>Geometry and configuration</i>	
Dimensions	No limitation (Explicit criteria for local buckling, combined loading are only given for straight pipes with $15 < D/t_2 < 45$)
Configurations	Tee's, wye's, PLEM or PLET, spools which are integrated part of the pipeline
Water depth	No limitation, see Sec.5 A201
<i>Loads</i>	
Pressure	No limitation
Temperature	No limitation Material properties need to be documented for temperatures above 50°C and 20°C for C-Mn steels and CRAs respectively, see Sec.5 C300
Global deformations	No limitation

Table 1-1 Scope and application summary (Continued)	
<i>Linepipe Material</i>	
General	Sec.7 A201 C-Mn steel linepipe is generally conforming to ISO 3183 Annex J but with modifications and amendments (245-555). Material grade limited to, including, X80 (DNV 555). CRA linepipe with specific requirements to 22Cr and 25Cr steel and 13Cr martensitic steel. Clad and lined linepipe. Supplementary requirements for sour service, fracture arrest properties, plastic deformation, dimensional tolerances and high utilization.
<i>Components</i>	
Design	Sec.5 F
Material and manufacture	Sec.8
<i>Fluids</i>	
Categories	Table 2-1 CO ₂ pipelines are in general covered by this standard in line with ISO13623. The following aspects needs special attention for CO ₂ pipelines; Material selection Corrosion and sour service evaluations Operation For these aspects, reference is made to DNV-RP-J202
Sour service	Generally conforming to ISO 15156
<i>Installation</i>	
Method	Sec.10 S-lay, J-lay, towing and laying methods introducing plastic deformations Installation requirements for risers as well as protective and anchoring structures are also included.
<ol style="list-style-type: none"> 1) Example of extra ordinary consequences may be pristine environment and exploration in arctic climate. 2) Umbilicals intended for control of subsea installations are not included in this standard. Individual pipes, within an umbilical, made of materials applicable to this standard, may be designed according to this standard. 3) Different parts of the pipeline system may be designed to different codes. It is important to identify differences between these at an early stage and assess these. Examples of conflicting requirements are; pressure definitions and system test pressure requirements. 4) The operator may apply this standard on sub-sets of the limits of this standard. Typical example of excluded items is smaller diameter piping such as kicker lines and designs these to e.g. ISO 15649. 	

A 400 Alternative methods and procedures

401 In case alternative methods and procedures to those specified in this Standard are used, it shall be demonstrated that the obtained safety level is equivalent to the one specified herein, see Sec.2 C500. Such Deviations shall be formally and rigorously justified and accepted by all relevant contracting parties.

A 500 Structure of standard

501 This Standard is based on limit state design. This implies that the same design criteria apply to both construction/installation and operation. All structural criteria are therefore given in Sec.5.

502 The Standard is organised as follows:

- Sec.1 contains the objectives and scope of the standard. It further introduces essential concepts, definitions and abbreviations.
- Sec.2 contains the fundamental safety philosophy and design principles. It introduces the safety class methodology and normal classification of safety classes. It gives overall requirements to systematic review or QRA. How this will affect the different phases is further described in subsections A300 in the different sections.
- Sec.3 contains requirements to concept development, establishment of design premises, with system design principles, pipeline safety and control system, and collection of environmental data.
- Sec.4 defines the design loads to be applied in Sec.5. It includes classification of loads into functional loads (including pressure), environmental loads, interference loads and accidental loads. Finally, it defines design cases with associated characteristic values and combinations.
- Sec.5 contains requirements to pipeline layout, system test and mill test. It contains description of the design (LRFD) format and characterisation of material strength for straight pipes and supports. Design criteria for the different limit states for all phases; installation, as-laid, commissioning and operation, are given.
- Sec.6 contains materials engineering and includes material selection, material specification (including required supplementary requirement to the linepipe specification), welding and corrosion control.

- Sec.7 contains requirements to linepipe. The requirements to C-Mn steels are based on ISO 3183. The section also includes requirements to CRAs and lined/clad pipe.
- Sec.8 contains requirements to materials, manufacture and fabrication of components and assemblies. Structural requirements to these components are given in Sec.5 F.
- Sec.9 contains requirements to corrosion protection and weight coating.
- Sec.10 contains requirements to offshore construction including installation, pre- and post-intervention and pre-commissioning.
- Sec.11 contains requirements to operation including commissioning, integrity management, repair, re-qualification, de-commissioning and abandonment of the submarine pipeline system.
- Sec.12 contains requirements to documentation for the submarine pipeline system from concept development to abandonment.
- Sec.13 is an informative section which discusses several aspects of the standard.
- The appendices are a compulsory part of the standard.
- Appendix A contains the requirements to Fracture Assessment of girth welds. It includes methodology, material characterisation and testing requirements.
- Appendix B details the requirements to materials testing including mechanical and corrosion testing as well as chemical analysis.
- Appendix C contains requirements to welding including qualification of welding procedures and construction welding.
- Appendix D contains requirements to Non-Destructive Testing (NDT) except Automated Ultrasonic Testing (AUT) of girth welds.
- Appendix E contains requirements to AUT of girth welds.
- Appendix F contains selected requirements to onshore parts of the submarine pipeline system.

503 Cross references are made as:

- nnn within the same sub-section (e.g. 512)
- X or Xnnn to another sub-section within the same section (e.g. C, C500 or C512)
- Section m, Section m X or Section m Xnnn to section, sub-section or paragraph outside the current section (e.g. Sec.5, Sec.5 C, Sec.5 C500 or Sec.5 C512).

Where m and nnn denotes numbers and X letter.

504 Additional requirements or modified requirements compared to the stated ISO standards are denoted by **AR** or **MR** by the end of the paragraph. This applies to Sec.7 B and Sec.9 C.

505 Modified requirements compared to the stated ISO standards are given in this standard by stating the ISO paragraph number in brackets prior to the modified requirements. This applies to Sec.8.

506 Guidance Notes provide additional information, clarification or examples to the paragraph in order to increase the understanding of the requirement. Guidance Notes are not binding.

B. References

B 100 Applicability

101 The following standards include provisions which, through reference in the text constitute provisions of this offshore standard.

102 References are either defined as normative or informative. Normative references in this document are indispensable for its application. Informative references provide additional information intended to assist the understanding or use of the document.

Guidance note:

Normative references are typically referred to as ‘testing shall be performed in accordance with ISO xxx’, while informative references are typically referred to as ‘testing may be performed in accordance with ISO xxx or ISO yyyy’, or ‘for testing, reference is given to DNV-RP-F xxx’.

---e-n-d---of---G-u-i-d-a-n-c-e---n-o-t-e---

103 In case of conflict between requirements of this standard and a referenced DNV Offshore Code, the requirements of the code with the latest revision date shall prevail.

Guidance note:

DNV Offshore code means any DNV Offshore Service Specification, DNV Offshore Standard, DNV Offshore Recommended Practice, DNV Guideline or DNV Classification Note.
Any conflict is intended to be removed in next revision of that document.

---e-n-d---of---G-u-i-d-a-n-c-e---n-o-t-e---

104 Where reference is made to codes other than DNV documents, the valid revision should be taken as the revision which was current at the date of issue of this standard.

105 In case of conflict between requirements of this code and code other than a DNV document, the requirements of this code shall prevail.

106 This standard is intended to comply with the ISO standard 13623: *Petroleum and natural gas industries - Pipeline transportation systems*, specifying functional requirements for offshore pipelines and risers.

Guidance note:

The following major deviations to ISO 13623 standard are known:

- This standard allows higher utilisation for fluid category A and C pipelines. This standard is here in compliance with ISO16708.
- For design life less than 33 years, a more severe environmental load is specified in this standard, in agreement with ISO16708.
- applying the supplementary requirements U, for increased utilisation, this standard allows 4% higher pressure containment utilisation than ISO 13623.
- the equivalent stress criterion in ISO 13623 sometimes allows higher utilisation than this standard.
- requirements to system pressure test (pressure test).
- minor differences may appear depending on how the pipeline has been defined in safety classes, ISO 13623 does not use the concept of safety classes.

This standard requires that the manufacture of line pipe and construction is performed to this standard.

---e-n-d---of---G-u-i-d-a-n-c-e---n-o-t-e---

107 The requirements to C-Mn steel linepipe of this standard include amendments and modifications that are additional to ISO 3183.

B 200 Offshore service specifications

The latest revision of the following documents applies:

DNV-OSS-301	Certification and Verification of Pipelines
DNV-OSS-302	Certification and Verification of Dynamic Risers
DNV-OSS-401	Technology Qualification Management

B 300 Offshore standards

The following documents contain provisions which, through reference in this text, constitute provisions of this Offshore Standard. The latest revision of the following document applies.

DNV-OS-A101	Safety Principles and Arrangements
DNV-OS-C101	Design of Offshore Steel Structures, General (LRFD method)
DNV-OS-C501	Composite Components
DNV-OS-D301	Fire Protection
DNV-OS-E201	Oil and Gas Processing Systems
DNV-OS-E301	Position Mooring
DNV-OS-F201	Dynamic Risers
DNV-OS-H101	Marine Operations, General

B 400 Recommended practices

The latest revision of the following documents applies:

DNV-RP-A203	Qualification Procedures for New Technology
DNV-RP-B401	Cathodic Protection Design
DNV-RP-C203	Fatigue Design of Offshore Steel Structures
DNV-RP-C205	Environmental Conditions and Environmental Loads
DNV-RP-F101	Corroded Pipelines
DNV-RP-F102	Pipeline Field Joint Coating & Field Repair of Linepipe Coating
DNV-RP-F103	Cathodic Protection of Submarine Pipelines by Galvanic Anodes
DNV-RP-F105	Free Spanning Pipelines
DNV-RP-F106	Factory applied pipeline coatings for corrosion control
DNV-RP-F107	Risk Assessment of Pipeline Protection

DNV-RP-F108	Fracture Control for Pipeline Installation Methods Introducing Cyclic Plastic Strain
DNV-RP-F109	On-bottom Stability Design of Submarine Pipelines
DNV-RP-F110	Global Buckling of Submarine Pipelines - Structural Design due to High Temperature/ High Pressure
DNV-RP-F111	Interference between Trawl Gear and Pipelines
DNV-RP-F112	Design of Duplex Stainless Steel Subsea Equipment Exposed to Cathodic Protection
DNV-RP-F113	Pipeline Subsea Repair
DNV-RP-F116	Integrity Management of Submarine Pipeline Systems
DNV-RP-F118	Pipe Girth Weld AUT System Qualification and Project Specific Procedure Validation
DNV-RP-F204	Riser Fatigue
DNV-RP-H101	Risk Management in Marine and Subsea Operations
DNV-RP-H102	Marine Operations during Removal of Offshore Installations
DNV-RP-H103	Modelling and analyses of Marine Operations
DNV-RP-J202	Design and Operation of CO ₂ Pipelines
DNV-RP-O501	Erosive Wear in Piping Systems - Summary

B 500 Rules

The latest revision of the following documents applies:

DNV	Rules for Classification of High Speed, Light Craft and Naval Surface Craft
-----	---

B 600 Certification notes and classification notes

The latest revision of the following documents applies:

DNV CN 1.2	Conformity Certification Services, Type Approval
DNV CN 1.5	Conformity Certification Services, Approval of Manufacturers, Metallic Materials
DNV CN 7	Non Destructive Testing
DNV CN 30.4	Foundations
DNV CN 30.6	Structural Reliability Analysis of Marine Structures

B 700 Other references

API RP 5L1	Recommended Practice for Railroad transportation of Line Pipe
API RP 5LW	Recommended Practice for Transportation of Line Pipe on Barges and Marine Vessels
API RP 17N	Subsea Production System Reliability and Technical Risk Management, First Edition
API RP 2201	Safe Hot Tapping Practices in the Petroleum & Petrochemical Industries-Fifth Edition
API Spec 6FA	Specification for Fire Test for Valves-Third Edition; Errata 12/18/2006
ASME B16.9	Factory-Made Wrought Buttwelding Fittings
ASME B31.3	Process Piping
ASME B31.4	Pipeline Transportation Systems for Liquid Hydrocarbons and Other Liquids
ASME B31.8	Gas Transmission and Distribution Systems
ASME BPVC-V	Boiler and Pressure Vessel Code Section V - Non-destructive Examination
ASME BPVC-VIII-1	Boiler and Pressure Vessel Code Section VIII - Div. 1 - Rules for Construction of Pressure Vessels
ASME BPVC-VIII-2	Boiler and Pressure Vessel Code Section VIII - Div. 2 - Rules for Construction of Pressure Vessels - Alternative Rules
ASNT	American Society for Nondestructive Testing. Central Certification Program (ACCP).
ASTM A 961	Standard Specification for Common Requirements for Steel Flanges, Forged Fittings, Valves, and Parts for Piping Applications
ASTM A370	Standard Test Methods and Definitions for Mechanical Testing of Steel Products
ASTM A388	Standard Practice for Ultrasonic Examination of Steel Forgings
ASTM A577	Standard specification for Ultrasonic Angle-Beam Examination of Steel Plates

ASTM A578	Standard Specification for Straight-Beam Ultrasonic Examination of Rolled Steel Plates for Special Applications
ASTM A609	Standard Practice for Castings, Carbon, Low Alloy, and Martensitic Stainless Steel, Ultrasonic Examination Thereof
ASTM C33	Standards specification for concrete aggregates
ASTM D 695	Standard Test Method for Compressive Properties of Rigid Plastics
ASTM E 165	Standard Practice for Liquid Penetrant Examination for General Industry
ASTM E 280	Standard Reference Radiographs for Heavy-Walled (4 1/2 to 12-in. (114 to 305-mm)) Steel Castings
ASTM E 309	Standard Practice for Eddy-Current Examination of Steel Tubular products Using Magnetic Saturation
ASTM E 317	Standard Practice for Evaluating Performance Characteristics of Pulse-Echo Testing Instruments and Systems Without the Use of Electronic Measurement Instruments
ASTM E 426	Standard Practice for Electromagnetic (Eddy Current) Examination of Seamless and Welded Tubular Products, Austenitic Stainless Steel and Similar Alloys
ASTM E 709	Standard Guide for Magnetic Particle Examination
ASTM E 797	Standard Practice for Measuring Thickness by Manual Ultrasonic Pulse-Echo Contact Method
ASTM E1212	Standard Practice for Quality Management Systems for Non-destructive Testing Agencies
ASTM E1417	Standard Practice for Liquid Penetrant Examination
ASTM E1444	Standard Practice for Magnetic Particle Examination
ASTM G 48	Standard Test Methods for Pitting and Crevice Corrosion Resistance of Stainless Steels and Related Alloys by Use of Ferric Chloride Solution
AWS C5.3	Recommended Practices for Air Carbon Arc Gouging and Cutting
BSI BS 7910	Guide to methods for assessing the acceptability of flaws in metallic structures
BSI PD 5500	Specification for unfired fusion welded pressure vessels
EN 287-1	Qualification test of welders - Fusion welding - Part 1: Steels
EN 473	Non destructive testing - Qualification and certification of NDT personnel - General principles
EN 583-6	Non destructive testing - Ultrasonic examination Part 6 - Time-of-flight diffraction technique as a method for detection and sizing of discontinuities
EN 1418	Welding personnel - Approval testing of welding operators for fusion welding and resistance weld setters for fully mechanized and automatic welding of metallic materials
EN 1591-1	Flanges and their joints - Design rules for gasketed circular flange connections - Part 1: Calculation method
EN 1998	Eurocode 8: Design of structures for earthquake resistance
EN 10204	Metallic products - Types of inspection documents
EN 12668-1	Non destructive testing - Characterisation and verification of ultrasonic examination equipment- Part 1: Instruments
EN 12668-2	Non destructive testing - Characterisation and verification of ultrasonic examination equipment- Part 2: Probes
EN 12668-3	Non destructive testing - Characterisation and verification of ultrasonic examination equipment- Part: 3: Combined equipment
EN 13445	Unfired pressure vessels - Part 3: Design
EN ISO 14175	Welding consumables - Gases and gas mixtures for fusion welding and allied processes
IEC 61511	Safety Instrumented Systems for the Process Industry Sector, First Edition, 2003
IMCA M140	DP Operations Guidance, Part 1
IMO Res. A.1047 (27)	Principles of safe manning
IMO MSC/Circ.645	Guidelines for Vessels with Dynamic Positioning Systems
ISO 148	Metallic materials – Charpy pendulum impact test
ISO 2400	Welds in steel – Reference block for the calibration of equipment for ultrasonic examination
ISO 3183	Petroleum and natural gas industries - Steel pipe for pipeline transportation systems

ISO 3452-1	Non-destructive testing – Penetrant testing – Part 1: General principles
ISO 3452-2	Non-destructive testing – Penetrant testing – Part 2: Testing of penetrant materials
ISO 3452-3	Non-destructive testing – Penetrant testing – Part 3: Reference test blocks
ISO 3452-4	Non-destructive testing – Penetrant testing – Part 4: Equipment
ISO 3452-5	Non-destructive testing – Penetrant testing – Part 5: Penetrant testing at temperatures higher than 50 degrees C
ISO 3452-6	Non-destructive testing – Penetrant testing – Part 6: Penetrant testing at temperatures lower than 10 degrees C
ISO 3690	Welding and allied processes – Determination of hydrogen content in ferritic steel arc weld metal
ISO 3834-2	Quality requirements for fusion welding of metallic materials – Part 2: Comprehensive quality requirements
ISO 4063	Welding and allied processes – Nomenclature of processes and reference numbers
ISO 4126	Safety devices for protection against excessive pressure
ISO 4136	Destructive tests on welds in metallic materials – Transverse tensile test
ISO 5173	Destructive tests on welds in metallic materials – Bend tests
ISO 5178	Destructive tests on welds in metallic materials – Longitudinal tensile test on weld metal in fusion welded joints
ISO 5817	Welding - Fusion-welded joints in steel, nickel, titanium and their alloys (beam welding excluded) - Quality levels for imperfections
ISO 6507	Metallic materials – Vickers hardness test
ISO 6847	Welding consumables - Deposition of a weld metal pad for chemical analysis
ISO 6892	Metallic materials – Tensile testing
ISO 6947	Welding and allied processes – Welding positions
ISO 7005-1	Metallic flanges – Part 1: Steel Flanges
ISO 7963	Non-destructive testing – Ultrasonic testing – Specification for calibration block No. 2
ISO 8501-1	Preparation of steel substrates before application of paints and related products – Visual assessment of surface cleanliness – Part 1: Rust grades and preparation grades of uncoated steel substrates and of steel substrates after overall removal of previous coatings
ISO 9000	Quality management systems – Fundamentals and vocabulary
ISO 9001	Quality management systems – Requirements
ISO 9606-1	Approval testing of welders – Fusion welding – Part 1: Steels
ISO 9712	Non-destructive testing – Qualification and certification of personnel
ISO 9769	Steel and iron – Review of available methods of analysis
ISO 9934-1	Non-destructive testing – Magnetic particle testing – Part 1: General principles
ISO 9934-2	Non-destructive testing – Magnetic particle testing – Part 2: Detection media
ISO 9934-3	Non-destructive testing – Magnetic particle testing – Part 3: Equipment
ISO 10375	Non-destructive testing – Ultrasonic inspection – Characterization of search unit and sound field
ISO 10474	Steel and steel products - Inspection documents
ISO 10893- 2	Non-destructive testing of steel tubes – Part 2: Automated eddy current testing of seamless and welded (except submerged arc-welded) steel tubes for the detection of imperfections
ISO 10893- 3	Non-destructive testing of steel tubes – Part 3: Automated full peripheral flux leakage testing of seamless and welded (except submerged arc-welded) ferromagnetic steel tubes for the detection of longitudinal and/or transverse imperfections
ISO 10893- 4	Non-destructive testing of steel tubes – Part 4: Liquid penetrant inspection of seamless and welded steel tubes for the detection of surface imperfections
ISO 10893- 5	Non-destructive testing of steel tubes – Part 5: Magnetic particle inspection of seamless and welded ferromagnetic steel tubes for the detection of surface imperfections
ISO 10893- 6	Non-destructive testing of steel tubes – Part 6: Radiographic testing of the weld seam of welded steel tubes for the detection of imperfections
ISO 10893- 7	Non-destructive testing of steel tubes – Part 7: Digital radiographic testing of the weld seam of welded steel tubes for the detection of imperfections

ISO 10893- 8	Non-destructive testing of steel tubes – Part 8: Automated ultrasonic testing of seamless and welded steel tubes for the detection of laminar imperfections
ISO 10893- 9	Non-destructive testing of steel tubes – Part 9: Automated ultrasonic testing for the detection of laminar imperfections in strip/plate used for the manufacture of welded steel tubes
ISO 10893-10	Non-destructive testing of steel tubes – Part 10: Automated full peripheral ultrasonic testing of seamless and welded (except submerged arc-welded) steel tubes for the detection of longitudinal and/or transverse imperfections
ISO 10893-11	Non-destructive testing of steel tubes – Part 12: Automated full peripheral ultrasonic thickness testing of seamless and welded (except submerged arc-welded) steel tubes
ISO 10893-12	Non-destructive testing of steel tubes – Part 12: Automated full peripheral ultrasonic thickness testing of seamless and welded (except submerged arc-welded) steel tubes
ISO 11484	Steel products – Employer's qualification system for non-destructive testing (NDT) personnel
ISO 12094	Steel – Ultrasonic testing for steel flat products of thickness equal to or greater than 6 mm
ISO 12715	Ultrasonic non-destructive testing – Reference blocks and test procedures for the characterization of contact search unit beam profiles
ISO / TS 12747	Petroleum and natural gas industries – Pipeline transportation systems – Recommended practice for pipeline life extension
ISO 13623	Petroleum and natural gas industries – Pipeline transportation systems
ISO 13847	Petroleum and natural gas industries – Pipeline transportation systems – Welding of pipelines
ISO 14284	Steel and iron – Sampling and preparation of samples for the determination of chemical composition
ISO 14723	Petroleum and natural gas industries - Pipeline transportation systems - Subsea pipeline valves
ISO 14731	Welding coordination – Tasks and responsibilities
ISO 14732	Welding personnel – Approval testing of welding operators for fusion welding and of resistance weld setters for fully mechanized and automatic welding of metallic materials
ISO 15156-1	Petroleum and natural gas industries - Materials for use in H ₂ S-containing environments in oil and gas production - Part 1: General principles for selection of cracking-resistant materials
ISO 15156-2	Petroleum and natural gas industries - Materials for use in H ₂ S-containing environments in oil and gas production - Part 2: Cracking-resistant carbon and low alloy steels, and the use of cast irons
ISO 15156-3	Petroleum and natural gas industries - Materials for use in H ₂ S-containing environments in oil and gas production - Part 3: Cracking-resistant CRAs (corrosion-resistant alloys) and other alloys
ISO 15589-1	Petroleum and natural gas industries – Cathodic protection of pipeline transportation systems – Part 1: On-land pipelines
ISO 15589-2	Petroleum and natural gas industries - Cathodic protection of pipeline transportation systems - Part 2: Offshore pipelines
ISO 15590-1	Petroleum and natural gas industries – Induction bends, fittings and flanges for pipeline transportation systems – Part 1: Induction bends
ISO 15590-2	Petroleum and natural gas industries – Induction bends, fittings and flanges for pipeline transportation systems – Part 2: Fittings
ISO 15590-3	Petroleum and natural gas industries – Induction bends, fittings and flanges for pipeline transportation systems – Part 3: Flanges
ISO 15614-1	Specification and qualification of welding procedures for metallic materials – Welding procedure test – Part 1: Arc and gas welding of steels and arc welding of nickel and nickel alloys
ISO 15618-2	Qualification testing of welders for underwater welding – Part 2: Diver-welders and welding operators for hyperbaric dry welding
ISO 15649	Petroleum and natural gas industries – Piping
ISO 16708	Petroleum and natural gas industries – Pipeline transportation systems – Reliability-based limit state methods

ISO/IEC 17025	General requirements for the competence of testing and calibration laboratories
ISO 17636	Non-destructive testing of welds – Radiographic testing of fusion-welded joints
ISO 17637	Non-destructive testing of welds – Visual testing of fusion-welded joints
ISO 17638	Non-destructive testing of welds – Magnetic particle testing
ISO 17640	Non-destructive testing of welds – Ultrasonic testing – Techniques, testing levels, and assessment
ISO 17643	Non-destructive testing of welds – Eddy current testing of welds by complex-plane analysis
ISO 19232	Non-destructive testing – Image quality of radiographs
ISO 19901-2	Petroleum and natural gas industries – Specific requirements for offshore structures – Part 2: Seismic design procedures and criteria
ISO 21809-1	Petroleum and natural gas industries – External coatings for buried or submerged pipelines used in pipeline transportation systems – Part 1: Polyolefin coatings (3-layer PE and 3-layer PP)
ISO 21809-2	Petroleum and natural gas industries – External coatings for buried or submerged pipelines used in pipeline transportation systems – Part 2: Fusion-bonded epoxy coatings
ISO 21809-3	Petroleum and natural gas industries – External coatings for buried or submerged pipelines used in pipeline transportation systems – Part 3: Field joint coatings
ISO 21809-5	Petroleum and natural gas industries – External coatings for buried or submerged pipelines used in pipeline transportation systems – Part 5: External concrete coatings
ISO 22825	Non-destructive testing of welds – Ultrasonic testing – Testing of welds in austenitic steels and nickel-based alloys
MSS SP-55	Quality standard for steel castings for valves, flanges, and fittings and other piping components (visual method for evaluation of surface irregularities).
MSS SP-75	Specification for High Test, Wrought, Butt Welding Fittings
NORDTEST	NT Techn. Report 394 (Guidelines for NDE Reliability Determination and Description, Approved 1998-04).
NORSOK L-005	Compact flanged connections
NORSOK U-009	Life extension for subsea systems
NORSOK Y-002	Life extension for transportation systems
NS 477	Welding - Rules for qualification of welding inspectors

Guidance note:

The latest revision of the DNV codes may be found in the publication list at the DNV website www.dnv.com.

Amendments and corrections to the DNV codes are published bi-annually on www.dnv.com. These shall be considered as mandatory part of the above codes.

---e-n-d---of---G-u-i-d-a-n-c-e---n-o-t-e---

C. Definitions

C 100 Verbal forms

101 *Shall*: Indicates a mandatory requirement to be followed for fulfilment or compliance with the present standard.

102 *Should*: Indicates that among several possibilities, one is recommended as particularly suitable, without mentioning or excluding others, or that a certain course of action is preferred but not necessarily required. Other possibilities may be applied subject to agreement in writing between Manufacturer/ Contractor and Purchaser. The expression may also be used to express interface criteria which may be modified subject to agreement.

103 *May*: Verbal form used to indicate a course of action permissible within the limits of the standard.

104 *Agreement, by agreement*: Unless otherwise indicated, this means agreed in writing between Manufacturer/ Contractor and Purchaser.

C 200 Definitions

201 *Abandonment*: Abandonment comprises the activities associated with taking a pipeline permanently out of operation. An abandoned pipeline cannot be returned to operation. Depending on the legislation this may require cover or removal.

- 202** *Accidental loads* a load with an annual frequency less than 10^{-2} , see Sec.5 D1000.
- 203** *Accumulated plastic strain*: Sum of plastic strain increments, irrespective of sign and direction. Strain increments shall be calculated from after the linepipe manufacturing, see Sec.5 D900.
- 204** *Additional requirements*: Requirements that applies to this standard, additional to other referred standards.
- 205** *As-built survey*: Survey of the installed and completed pipeline system that is performed to verify that the completed installation work meets the specified requirements, and to document deviations from the original design, if any.
- 206** *As-laid survey*: Survey performed either by continuous touchdown point monitoring or by a dedicated vessel during installation of the pipeline.
- 207** *Assemblies, in-line*: Pipeline components (see Table 1-1 and 291), buckle and fracture arrestors, PLEMs and PLETs which are integrated part of the pipeline and connected or welded to the pipeline during installation.
- 208** *Assemblies, pipeline*: Risers, pipe strings (for reeling or towing), spools which are welded onshore (see Sec.8 F).
- 209** *Atmospheric zone*: The part of the pipeline system above the splash zone.
- 210** *Buckling, global*: Buckling mode which involves a substantial length of the pipeline, usually several pipe joints and not gross deformations of the cross section; upheaval buckling is an example thereof, see Sec.5 D700.
- 211** *Buckling, local*: Buckling mode confined to a short length of the pipeline causing gross changes of the cross section; collapse, localised wall wrinkling and kinking are examples thereof, see Sec.5 D300.
- 212** *Characteristic load (L_c)*: The reference value of a load to be used in the determination of load effects. The characteristic load is normally based upon a defined fractile in the upper end of the distribution function for load, see Sec.4 G.
- 213** *Characteristic resistance (R_c)*: The reference value of structural strength to be used in the determination of the design strength. The characteristic resistance is normally based upon a defined fractile in the lower end of the distribution function for resistance. See Sec.5 C200.
- 214** *Clad pipe (C)*: Pipe with internal (corrosion resistant) liner where the bond between (linepipe) backing steel and cladding material is metallurgical.
- 215** *Clamp*: Circumferential structural element, split into two or more parts. Examples; connecting two hubs in a mechanical connector or two pipe half-shells for repair purpose
- 216** *Code*: Common denotation on any specification, rule, standard guideline, recommended practice or similar.
- 217** *Coiled tubing*: Continuously-milled tubular product manufactured in lengths that require spooling onto a take-up reel, during the primary milling or manufacturing process.
- 218** *Commissioning*: Activities associated with the initial filling of the pipeline system with the fluid to be transported, part of operational phase.
- 219** *Commissioning, De-*: Activities associated with taking the pipeline temporarily out of service.
- 220** *Commissioning, Pre-*: Activities after tie-in/connection and prior to commissioning including system pressure testing, de-watering, cleaning and drying.
- 221** *Concept development phase*: The concept development phase will typically include both business evaluations, collecting of data and technical early phase considerations.
- 222** *Condition load effect factor (γ_C)*: A load effect factor included in the design load effect to account for specific load conditions, see Sec.4 G300 Table 4-5.
- 223** *Connector*: Mechanical device used to connect adjacent components in the pipeline system to create a structural joint resisting applied loads and preventing leakage. Examples: Threaded types, including (i) one male fitting (pin), one female fitting (integral box) and seal ring(s), or (ii) two pins, a coupling and seals sea ring(s); Flanged types, including two flanges, bolts and gasket/seal ring; Clamped hub types, including hubs, clamps, bolts and seal ring(s); Dog-type connectors.
- 224** *Construction phase*: The construction phase will typically include manufacture, fabrication and installation activities. Manufacture activities will typically include manufacture of linepipe and corrosion protection and weight coating. Fabrication activities will typically include fabrication of pipeline components and assemblies. Installation activities will typical include pre- and post intervention work, transportation, installation, tie-in and pre-commissioning.
- 225** *Contractor*: A party contractually appointed by the Purchaser to fulfil all, or any of, the activities associated with design, construction and operation.
- 226** *Corrosion allowance (t_{cor})*: Extra wall thickness added during design to compensate for any reduction in wall thickness by corrosion (internally/externally) during operation, see Sec.6 D200.
- 227** *Corrosion control*: All relevant measures for corrosion protection, as well as the inspection and monitoring of corrosion, see Sec.6 D100.

- 228** *Corrosion protection*: Use of corrosion resistant materials, corrosion allowance and various techniques for “corrosion mitigation”, see Sec.6 D100
- 229** *Coupling*: Mechanical device to connect two bare pipes to create a structural joint resisting applied loads and preventing leakage.
- 230** *Design*: All related engineering to design the pipeline including both structural as well as material and corrosion.
- 231** *Design case*: Characterisation of different load categories, see Sec.4 A500.
- 232** *Design life*: The initially planned time period from initial installation or use until permanent decommissioning of the equipment or system. The original design life may be extended after a re-qualification.
- 233** *Design premises*: A set of project specific design data and functional requirements which are not specified or which are left open in the standard to be prepared prior to the design phase.
- 234** *Design phase*: The design phase will typically be split into FEED-phase, basic design and detail design. For each design phase, the same design tasks are repeated but in more and more specific and detailed level.
- 235** *Dynamic riser*: A riser which motion will influence the hydrodynamic load effects or where inertia forces become significant.
- 236** *Engineering Critical Assessment (ECA)*: Fracture mechanics assessment of the acceptability of flaws in metallic materials.
- 237** *Erosion*: Material loss due to repeated impact of sand particles or liquid droplets.
- 238** *Fabrication*: Activities related to the assembly of objects with a defined purpose in a pipeline system.
- 239** *Fabrication factor* (α_{fab}): Factor on the material strength in order to compensate for material strength reduction (in hoop direction) from cold forming during manufacturing of linepipe, see Table 5-5.
- 240** *Fabricator*: The party performing the fabrication.
- 241** *Failure*: An event affecting a component or system and causing one or both of the following effects:
- loss of component or system function; or
 - deterioration of functional capability to such an extent that the safety of the installation, personnel or environment is significantly reduced.
- 242** *Fatigue*: Cyclic loading causing degradation of the material.
- 243** *Fittings*: Elbows, caps, tees, single or multiple extruded headers, reducers and transition sections
- 244** *Flange*: Collar at the end of a pipe usually provided with holes in the pipe axial direction for bolts to permit other objects to be attached to it.
- 245** *Fluid categorisation*: Categorisation of the transported fluid according to hazard potential as defined in Table 2-1.
- 246** *Fractile*: The p-fractile (or percentile) and the corresponding fractile value x_p is defined as:

$$F(x_p) = p$$

F is the distribution function for x_p .

- 247** *Hub*: The parts in a mechanical connector joined by a clamp.
- 248** *Hydrogen Induced Cracking (HIC)*: Internal cracking of rolled materials due to a build-up of hydrogen pressure in micro-voids (Related terms: stepwise cracking).
- 249** *Hydrogen Induced Stress Cracking (HISC)*: Cracking that results from the presence of hydrogen in a metal while subjected to tensile stresses (residual and/or applied). The source of hydrogen may be welding, corrosion, cathodic protection, electroplating or some other electrochemical process. Crack growth proceeds by a hydrogen embrittlement mechanism at the crack tip, i.e. the bulk material is not necessarily embrittled by hydrogen. HISC by corrosion in presence of hydrogen sulphide is referred to as Sulphide Stress Cracking (SSC).
- 250** *Hydro-test or Hydrostatic test*: See Mill pressure test
- 251** *Inspection*: Activities such as measuring, examination, weighing testing, gauging one or more characteristics of a product or service and comparing the results with specified requirements to determine conformity.
- 252** *Installation (activity)*: The operations related to installing the equipment, pipeline or structure, e.g. pipeline laying, tie-in, piling of structure etc.
- 253** *Installation (object)*: See Offshore installation.
- 254** *Installation Manual (IM)*: A document prepared by the Contractor to describe and demonstrate that the installation method and equipment used by the Contractor will meet the specified requirements and that the

results can be verified.

255 Integrity: See Pipeline integrity.

256 Jointer: Two lengths of pipe welded together by the manufacturer to build up one complete ($\approx 40'$) pipe joint.

257 J-tube: A J-shaped tube installed on a platform, through which a pipe can be pulled to form a riser. The J-tube extends from the platform deck to and inclusive of the bottom bend at the seabed. The J-tube supports connect the J-tube to the supporting structure.

258 Limit state: A state beyond which the structure no longer satisfies the requirements. The following limit states categories are of relevance for pipeline systems:

- *Serviceability Limit State (SLS):* A condition which, if exceeded, renders the pipeline unsuitable for normal operations. Exceedance of a serviceability limit state category shall be evaluated as an accidental limit state.
- *Ultimate Limit State (ULS):* A condition which, if exceeded, compromises the integrity of the pipeline.
- *Fatigue Limit State (FLS):* An ULS condition accounting for accumulated cyclic load effects.
- *Accidental Limit State (ALS):* An ULS due to accidental (in-frequent) loads.

259 Lined pipe (L): Pipe with internal (corrosion resistant) liner where the bond between (linepipe) backing steel and liner material is mechanical.

260 Load: Any action causing stress, strain, deformation, displacement, motion, etc. to the equipment or system.

261 Load categories: Functional load, environmental load, interference load or accidental load, see Sec.4 A.

262 Load effect: Effect of a single load or combination of loads on the equipment or system, such as stress, strain, deformation, displacement, motion, etc.

263 Load effect combinations: See Sec.4 A.

264 Load effect factor (γ_F , γ_E , γ_A): The partial safety factor by which the characteristic load effect is multiplied to obtain the design load effect, see Sec.4 G300.

265 Load scenarios: Scenarios which shall be evaluated, see Sec.4 A.

266 Location class: A geographic area of pipeline system, see Table 2-2.

267 Lot: Components of the same size and from the same heat, the same heat treatment batch.

268 Manufacture: Making of articles or materials, often in large volumes. In relation to pipelines, refers to activities for the production of linepipe, anodes and other components and application of coating, performed under contracts from one or more Contractors.

269 Manufacturer: The party who is contracted to be responsible for planning, execution and documentation of manufacturing.

270 Manufacturing Procedure Specification (MPS): A manual prepared by the Manufacturer to demonstrate how the specified properties may be achieved and verified through the proposed manufacturing route.

271 Material resistance factor (γ_m): Partial safety factor transforming a characteristic resistance to a lower fractile resistance, see Table 5-2.

272 Material strength factor (α_v): Factor for determination of the characteristic material strength reflecting the confidence in the yield stress see Table 5-4.

273 Mill pressure test: The hydrostatic strength test performed at the mill, see Sec.5 B200.

274 Nominal outside diameter: The specified outside diameter.

275 Nominal pipe wall thickness: The specified non-corroded pipe wall thickness of a pipe, which is equal to the minimum steel wall thickness plus the manufacturing tolerance.

276 Nominal strain: The total engineering strain not accounting for strain concentration factors.

277 Nominal plastic strain: The nominal strain minus the linear strain derived from the stress-strain curve, see Sec.5 Figure 3.

278 Offshore installation (object): General term for mobile and fixed structures, including facilities, which are intended for exploration, drilling, production, processing or storage of hydrocarbons or other related activities/fluids. The term includes installations intended for accommodation of personnel engaged in these activities. Offshore installation covers subsea installations and pipelines. The term does not cover traditional shuttle tankers, supply boats and other support vessels which are not directly engaged in the activities described above.

279 Operation, Incidental: Conditions which that are not part of normal operation of the equipment or system. In relation to pipeline systems, incidental conditions may lead to incidental pressures, e.g. pressure surges due to sudden closing of valves, or failure of the Pipeline Control system and activation of the Pipeline safety system.

280 Operation, Normal: Conditions that arise from the intended use and application of equipment or system, including associated condition and integrity monitoring, maintenance, repairs etc. In relation to pipelines, this

should include steady flow conditions over the full range of flow rates, as well as possible packing and shut-in conditions where these occur as part of routine operation.

281 Operation phase: The operation phase starts with the commissioning, filling the pipeline with the intended fluid. The operation phase will include inspection and maintenance activities. In addition, the operation phase may also include modifications, re-qualifications and de-commissioning.

282 Operator (Pipeline-): The party ultimately responsible for concept development, design, construction and operation of the pipeline system. The operator may change between phases.

283 Out of roundness: The deviation of the linepipe perimeter from a circle. This can be stated as ovalisation (%), or as local out of roundness, e.g. flattening, (mm).

284 Ovalisation: The deviation of the perimeter from a circle. This has the form of an elliptic cross section

285 Parameter operating envelop: Limitations of the operating parameters in the pipeline control system that will ensure that the parameter control envelope is not exceeded with an acceptable reliability. This includes all relevant parameters and links between these including minimum values if relevant. This will first be established in the concept phase (mainly based on hydraulic analyses), extended in the design phase and re-assessed in the operation phase.

286 Parameter safety envelop: Limitations of the operating parameters in the pipeline safety system that will ensure that the parameter safety envelope is not exceeded with an acceptable reliability. This will first be established in the concept phase (mainly based on hydraulic analyses), extended in the design phase and re-assessed in the operation phase.

287 Partial safety factor: A factor by which the characteristic value of a variable is modified to give the design value (i.e. a load effect, condition load effect, material resistance or safety class resistance factor), see Sec.5 C.

288 Pipe, High Frequency Welded (HFW): Pipe manufactured by forming from strip and with one longitudinal seam formed by welding without the addition of filler metal. The longitudinal seam is generated by high frequency current applied by induction or conduction.

289 Pipe, Seamless (SMLS): Pipe manufactured in a hot forming process resulting in a tubular product without a welded seam. The hot forming may be followed by sizing or cold finishing to obtain the required dimensions.

290 Pipe, Submerged Arc-Welded Longitudinal or Helical (SAWL or SAWH): Pipe manufactured by forming from strip or plate, and with one longitudinal (SAWL) or helical (SAWH) seam formed by the submerged arc process with at least one pass made on the inside and one pass from the outside of the pipe.

291 Pipeline Components: Any items which are integral parts of the submarine pipeline system such as bends, fittings, flanges, valves, mechanical connectors, CP isolation joints, anchor flanges, buckle and fracture arrestors, pig traps, repair clamps and repair couplings (see Sec.8).

292 Pipeline Control System: The basic process control system that ensures that the operating parameters are within the operating parameter envelop

293 Pipeline Integrity: Pipeline integrity is the ability of the submarine pipeline system to operate safely and withstand the loads imposed during the pipeline lifecycle.

294 Pipeline Integrity Management: The pipeline integrity management process is the combined process of threat identification, risk assessments, planning, monitoring, inspection, maintenance etc. to maintain pipeline integrity.

295 Pipeline Safety System: The system as per in IEC 61511 that ensures that the operating parameters are within the safety parameter envelop. The safety parameters can be, but are not limited to, flow, internal pressure, temperature or composition.

296 Pipeline System: pipeline with compressor or pump stations, pipeline control stations, metering, tankage, supervisory control and data acquisition system (SCADA), safety systems, corrosion protection systems, and any other equipment, facility or building used in the transportation of fluids.

See also Submarine pipeline system.

297 Pipeline walking: Accumulation of incremental axial displacement of pipeline due to start-up and shut-down.

298 Positioning/heading keeping: maintaining a desired position/heading within the normal execution of the control system and environmental conditions.

299 Position/heading reference system: All hardware, software and sensors that supply information and or corrections necessary to give positioning/heading reference.

C 300 Definitions (continued)

301 Pressure test: See System pressure test

302 Pressure, Collapse (p_c): Characteristic resistance against external over-pressure, see Sec.5 D400.

303 Pressure, Design (p_d): In relation to pipelines, this is the maximum internal pressure during normal operation, referred to the same reference elevation as the design pressure, see Figure 1 and Sec.3 B300.

304 Pressure, Hydro- or Hydrostatic test: See Pressure, Mill test.

305 Pressure, Incidental (p_{inc}): In relation to pipelines, this is the maximum internal pressure the pipeline or pipeline section is designed to withstand during any incidental operating situation, referred to a specified reference elevation, see Figure 1 and Sec.3 D200.

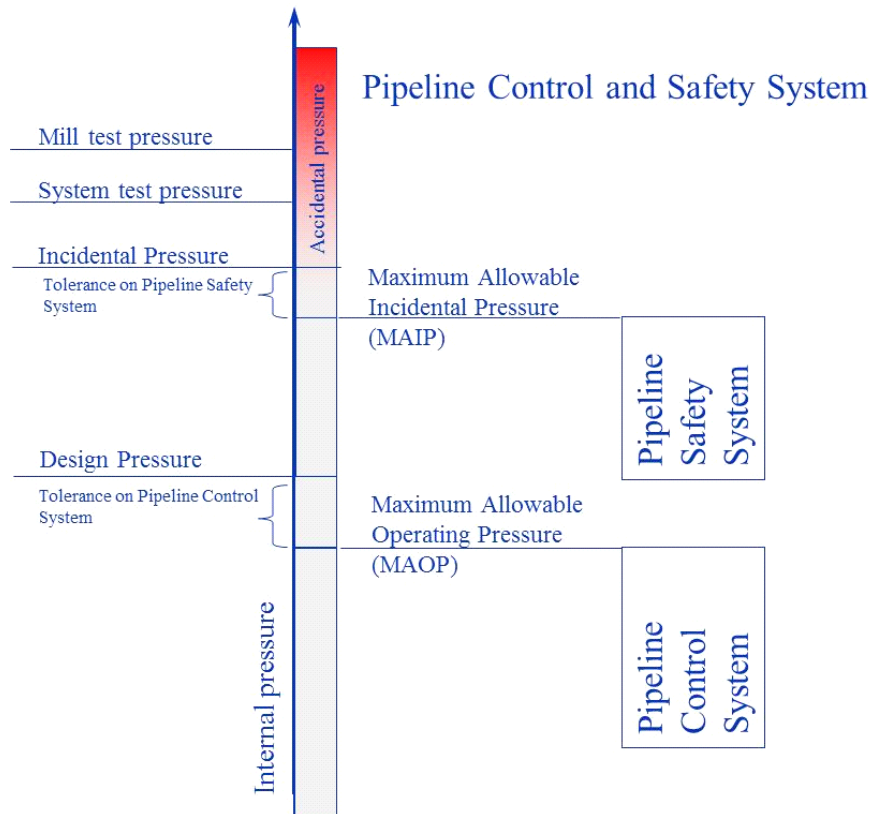

Figure 1
Pressure definitions

306 Pressure, Initiation: The external over-pressure required to initiate a propagating buckle from an existing local buckle or dent (100-year value), see Sec.5 D500.

307 Pressure, Local; Local Design, Local Incidental or Local Test: In relation to pipelines, this is the internal pressure at any point in the pipeline system or pipeline section for the corresponding design pressure, incidental pressure or test pressure adjusted for the column weight, see Sec.4 B200.

308 Pressure, Maximum Allowable Incidental (MAIP): In relation to pipelines, this is the maximum pressure at which the pipeline system shall be operated during incidental (i.e. transient) operation. The maximum allowable incidental pressure is defined as the maximum incidental pressure less the positive tolerance of the Pipeline Safety System, see Figure 1 and Sec.3 D200.

309 Pressure, Maximum Allowable Operating (MAOP): In relation to pipelines, this is the maximum pressure at which the pipeline system shall be operated during normal operation. The maximum allowable operating pressure is defined as the design pressure less the positive tolerance of the Pipeline Control System (PCS), see Figure 1 and Sec.3 D200.

310 Pressure, Mill test (p_t): The test pressure applied to pipe joints and pipe components upon completion of manufacture and fabrication, see Sec.5 B200.

311 Pressure, Propagating (p_{pv}): The lowest pressure required for a propagating buckle to continue to propagate, see Sec.5 D500.

312 Pressure, shut-in: The maximum pressure that can be attained at the wellhead during closure of valves closest to the wellhead (wellhead isolation). This implies that pressure transients due to valve closing shall be included.

313 Pressure, System test (p_{test}): In relation to pipelines, this is the internal pressure applied to the pipeline or pipeline section during testing on completion of installation work to test the pipeline system for tightness (normally performed as hydrostatic testing), see Sec.5 B200.

- 314** *Pressure, Test*: See Pressure, System test.
- 315** *Pup Piece*: An extra linepipe piece added to a component in order to build up a certain overall length, typically for construction and/or fabrication purpose.
- 316** *Purchaser*: The owner or another party acting on his behalf, who is responsible for procuring materials, components or services intended for the design, construction or modification of a installation or a pipeline.
- 317** *Quality Assurance (QA)*: Planned and systematic actions necessary to provide adequate confidence that a product or service will satisfy given requirements for quality. (The Quality Assurance actions of an organisation is described in a Quality Manual stating the Quality Policy and containing the necessary procedures and instructions for planning and performing the required actions).
- 318** *Quality Control (QC)*: The internal systems and practices (including direct inspection and materials testing), used by manufacturers to ensure that their products meet the required standards and specifications.
- 319** *Quality Plan (QP)*: The document setting out the specific quality practices, resources and sequence of activities relevant to a particular product, project or contract. A quality plan usually makes reference to the part of the quality manual (e.g. procedures and work instructions) applicable to the specific case.
- 320** *Ratcheting*: Accumulated deformation during cyclic loading, especially for diameter increase, see Sec.5 D1200. Does not include so called Pipeline Walking.
- 321** *Reliability*: The probability that a component or system will perform its required function without failure, under stated conditions of operation and maintenance and during a specified time interval.
- 322** *Re-qualification*: The re-assessment of a design due to modified design premises and/or sustained damage.
- 323** *Resistance*: The capability of a structure, or part of a structure, to resist load effects, see Sec.5 C200.
- 324** *Riser*: A riser is defined as the connecting piping or flexible pipe between a submarine pipeline on the seabed and installations above water. The riser extends to the above sea emergency isolation point between the import/export line and the installation facilities, i.e. riser ESD valve.
- 325** *Riser support/clamp*: A structure which is intended to keep the riser in place.
- 326** *Riser system*: A riser system is considered to comprise riser, its supports, all integrated pipelining components, and corrosion protection system.
- 327** *Risk*: The qualitative or quantitative likelihood of an accidental or unplanned event occurring, considered in conjunction with the potential consequences of such a failure. In quantitative terms, risk is the quantified probability of a defined failure mode times its quantified consequence.
- 328** *Safety Class (SC)*: In relation to pipelines; a concept adopted to classify the significance of the pipeline system with respect to the consequences of failure, see Sec.2 C400.
- 329** *Safety class resistance factor (γ_{SC})*: Partial safety factor which transforms the lower fractile resistance to a design resistance reflecting the safety class, see Table 5-3.
- 330** *Single event*: Straining in one direction.
- 331** *Slamming*: Impact load on an approximately horizontal member from a rising water surface as a wave passes. The direction is mainly vertical.
- 332** *Slapping*: Impact load on an approximately vertical surface due to a breaking wave. The direction is mainly horizontal.
- 333** *Specified Minimum Tensile Strength (SMTS)*: The minimum tensile strength specified by this standard. For supplementary requirement U, this corresponds to a statistical value equal to or lower than the mean – three standard deviations.
- 334** *Specified Minimum Yield Stress (SMYS)*: The minimum yield stress specified by this standard. For supplementary requirement U, this corresponds to a statistical value equal to or lower than the mean two standard deviations.
- 335** *Splash zone*: External surfaces of a structure or pipeline that are periodically in and out of the water by the influence of waves and tides.
- 336** *Splash Zone Height*: The vertical distance between splash zone upper limit and splash zone lower limit.
- 337** *Splash Zone Lower Limit (LSZ)* is determined by:

$$LSZ = |L1| - |L2| - |L3|$$

L1 = lowest astronomic tide level (LAT)

L2 = 30% of the Splash zone wave-related height defined in 334

L3 = upward motion of the riser.

338 *Splash Zone Upper Limit (USZ)* is determined by:

$$USZ = |U1| + |U2| + |U3|$$

U1 = highest astronomic tide level (HAT)

U2 = 70% of the splash zone wave-related height defined in 334

U3 = settlement or downward motion of the riser, if applicable

339 *Splash zone wave-related height*: The wave height with a probability of being exceeded equal to 10^{-2} , as determined from the long term distribution of individual waves. If this value is not available, an approximate value of the splash zone height may be taken as:

$$0.46 H_s^{100}$$

Where

H_s^{100} = significant wave height with a 100 year return period

340 *Spool*: A pipe section which is used to connect a pipeline to another subsea structure (e.g. manifold, PLET, tee) or riser.

341 *Submarine Pipeline*: A submarine pipeline is defined as the part of a submarine pipeline system which, except for pipeline risers is located below the water surface at maximum tide. The pipeline may, be resting wholly or intermittently on, or buried below, the seabed.

342 *Submarine Pipeline System*: a submarine pipeline system extends to the first weld beyond:

- the first valve, flange or connection above water on platform or floater
- the connection point to the subsea installation (i.e. piping manifolds are not included)
- the first valve, flange, connection or insulation joint at a landfall unless otherwise specified by the on-shore legislation.

The component above (valve, flange, connection, insulation joint) includes any pup pieces, i.e. the submarine pipeline system extends to the weld beyond the pup piece.

343 *Submerged zone*: The part of the pipeline system or installation below the splash zone, including buried parts.

344 *Supplementary requirements*: Requirements for material properties of linepipe that are extra to the additional requirements to ISO and that are intended to apply to pipe used for specific applications.

345 *System effects*: System effects are relevant in cases where many pipe sections are subjected to an invariant loading condition, and potential structural failure may occur in connection with the lowest structural resistance among the pipe sections, see Sec.4 G300.

346 *System pressure test*: Final test of the complete pipeline system, see Sec.5 B200.

347 *Target nominal failure probability*: A nominal acceptable probability of structural failure. Gross errors are not included, see Sec.2 C500.

348 *Temperature, design, maximum*: The highest possible temperature profile to which the equipment or system may be exposed to during installation and operation (100-year value).

349 *Temperature, design, minimum*: The lowest possible temperature profile to which the component or system may be exposed to during installation and operation (100-year value). This may be applied locally, see Sec.4 B106.

350 *Temperature, operation*: Representative temperature profile(s) during operation.

351 *Test unit*: A prescribed quantity of pipe that is made to the specified outer diameter and specified wall thickness, by the same pipe-manufacturing process, from the same heat, and under the same pipe-manufacturing conditions.

352 *Threats*: An indication of impending danger or harm to the pipeline system.

353 *Tide*: See Sec.3 C400.

354 *Ultimate Tensile Strength (UTS)*: The measured ultimate tensile strength.

355 *Verification*: An examination to confirm that an activity, a product or a service is in accordance with specified requirements.

356 *Weld, strip/plate end*: Weld that joins strip or plate joints together.

357 *Work*: All activities to be performed within relevant contract(s) issued by Owner, Operator, Contractor or Manufacturer.

358 *Yield Stress (YS)*: The measured yield tensile stress.

359 *100-year load effect*: The load with an annual probability of 10^{-2} of exceedance in a period of one year

D. Abbreviations and Symbols

D 100 Abbreviations

ALS	Accidental Limit State
AR	Additional Requirement to the stated ISO standard
API	American Petroleum Institute
APS	Application Procedure Specification
ASD	Allowable Stress Design
ASME	American Society of Mechanical Engineers
ASTM	American Society for Testing and Materials
AUT	Automated Ultrasonic Testing
BE	Best Estimate
BM	Base material
BS	British Standard
C	Clad pipe
C-Mn	Carbon Manganese
CMOD	Crack Mouth Opening Displacement
CP	Cathodic Protection
CRA	Corrosion Resistant Alloy
CTOD	Crack Tip Opening Displacement
CVN	Charpy V-Notch
DAC	Distance Amplitude Correction
DC	Displacement controlled
DFI	Design, Fabrication and Installation
DNV	Det Norske Veritas
DP	Dynamic Positioning
DWTT	Drop Weight Tear Testing
EBW	Electron Beam Welded
EC	Eddy Current Testing
ECA	Engineering Critical Assessment
EDI	Electronic Data Interchange
EMS	Electro Magnetic Stirring
ERW	Electric Resistance Welding
ESD	Emergency Shut Down
FEED	Front End Engineering Design
FJC	Field Joint Coating
FLS	Fatigue Limit State
FMEA	Failure Mode Effect Analysis
G-FCAW	Gas-Flux Core Arc Welding
GMAW	Gas Metal Arc Welding
HAT	Highest Astronomical Tide
HAZ	Heat Affected Zone
HAZOP	Hazard and Operability Study
HFW	High Frequency Welding
HIPPS	High Integrity Pressure Protection System
HIC	Hydrogen Induced Cracking
HISC	Hydrogen Induced Stress Cracking
ID	Internal Diameter
IM	Installation Manual
IMCA	International Marine Contractor's Association
ISO	International Organization for Standardization
ITP	Inspection and Testing Plan

JCO	Pipe fabrication process for welded pipes
JCOE	Pipe fabrication process for welded pipes, expanded
J-R curve	Plot of resistance to stable crack growth for establishing crack extension
KV	Charpy value
KVL	Charpy value in pipe longitudinal direction
KVT	Charpy value in pipe transversal direction
L	Lined pipe or load effect
LAT	Lowest Astronomic Tide
LB	Lower Bound
LC	Load controlled
LBW	Laser Beam Welded
LBZ	Local Brittle Zones
LRFD	Load and Resistance Factor Design
LSZ	Splash Zone Lower Limit
M/A	Martensitic/Austenite
MAIP	Maximum Allowable Incidental Pressure
MAOP	Maximum Allowable Operating Pressure
MDS	Material Data Sheet
MPQT	Manufacturing Procedure Qualification Test
MPS	Manufacturing Procedure Specification
MR	Modified Requirement to the stated ISO standard
MSA	Manufacturing Survey Arrangement
MT	Magnetic Particle Testing
MWP	Multiple Welding Process
N	Normalised
NACE	National Association of Corrosion Engineers
NDT	Non-Destructive Testing
P	Production
PCS	Pipeline Control System
PFD	Probability of Failure on Demand
PIM	Pipeline Integrity Management
PPT	Pre-Production Trial
PRE	Pitting Resistance Equivalent
PRL	Primary Reference Level
PSS	Pipeline Safety System
PT	Penetrant Testing
PTFE	Poly Tetra Flour Ethylene
PWHT	Post weld heat treatment
pWPS	preliminary Welding Procedure Specification
PQT	Procedure Qualification Trial
Q	Qualification
QA	Quality Assurance
QC	Quality Control
QP	Quality Plan
QRA	Quantitative Risk Assessment
QT	Quenched and Tempered
ROV	Remotely Operated Vehicle
RT	Radiographic testing
SAWH	Submerged Arc-welding Helical
SAWL	Submerged Arc-welding Longitudinal
SC	Safety Class
SCF	Stress Concentration Factor

SCR	Steel Catenary Riser
SENB	Single Edge Notched Bend fracture mechanics specimen
SENT	Single Edge Notched Tension fracture mechanics specimen
SLS	Serviceability Limit State
SMAW	Shielded Metal Arc Welding
SMLS	Seamless Pipe
SMTS	Specified Minimum Tensile Strength
SMYS	Specified Minimum Yield Stress
SN	Stress versus number of cycles to failure
SNCF	Strain Concentration Factor
SRA	Structural Reliability Analysis
SSC	Sulphide Stress Cracking
ST	Surface testing
TCM	Two Curve Method
TMCP	Thermo-Mechanical Controlled Process
TOFD	Time of Flight Diffraction
TRB	Three Roll Bending
UB	Upper Bound
ULS	Ultimate Limit State
UO	Pipe fabrication process for welded pipes
UOE	Pipe fabrication process for welded pipes, expanded
USZ	Splash Zone Upper Limit
UT	Ultrasonic testing
UTS	Ultimate Tensile Strength
VT	Visual Testing
WM	Weld Metal
WPQT	Welding Procedure Qualification Test
WPS	Welding Procedure Specification
YS	Yield Stress

D 200 Symbols – latin characters

a	Crack depth
A	Cross section area
A_e	$\frac{\pi}{4} \cdot D^2$ Pipe external cross section area
A_i	$\frac{\pi}{4} (D - 2 \cdot t)^2$ Pipe internal cross section area
A_s	$\pi \cdot (D - t) \cdot t$ Pipe steel cross section area
B	Specimen width
D	Nominal outside diameter.
D_{fat}	Miner's sum
DFE	Design Fatigue Factor, Eq. 5.32
D_i	$D - 2t_{nom}$ Nominal internal diameter
D_{max}	Greatest measured inside or outside diameter
D_{min}	Smallest measured inside or outside diameter
E	Young's Modulus
f_0	$\frac{D_{max} - D_{min}}{D}$ Ovality
f_{cb}	Minimum of f_y and $f_u/1.15$, see Eq. 5.9
f_u	Tensile strength to be used in design, see Eq. 5.5
$f_{u,temp}$	Derating on tensile stress to be used in design, see Eq. 5.5

f_y	Yield stress to be used in design, see Eq. 5.4
$f_{y,temp}$	Derating on yield stress to be used in design, see Eq. 5.4
g	Gravity acceleration
H	Residual lay tension, see Eq. 4.10 and Eq. 4.11
h_{bead}	Height of weld bead including misalignment, see e.g. Table D-4
h_l	Elevation at pressure point, see Eq. 4.1
H_p	Permanent plastic dent depth
h_{ref}	Elevation at pressure reference level, see Eq. 4.1
H_s	Significant wave height
ID	Nominal inside diameter
k	number of stress blocks
L	Characteristic load effect
M	Moment
N	Axial force in pipe wall (“true” force) (tension is positive) or Number of load effect cycles
n_i	Number of stress blocks
N_i	Number of stress cycles to failure at constant amplitude
O	Out of roundness, $D_{max} - D_{min}$
p_b	Pressure containment resistance, see Eq. 5.8
p_c	Characteristic collapse pressure, see Eq. 5.11
p_d	Design pressure
P_{Di}	(i’th) Damaging event, see Eq. 5.34
p_e	External pressure
p_{el}	Elastic collapse pressure, see Eq. 5.12
p_f	Failure probability
$p_{f,T}$	Target nominal failure probability, see Table 2-5
p_h	Mill test pressure, see Sec.7 E100
p_i	Characteristic internal pressure
p_{inc}	Incidental pressure
p_{init}	Initiation pressure
p_{ld}	Local design pressure
p_{li}	Local incidental pressure, see Eq. 4.1
p_{lt}	Local test pressure (system test), see Eq. 4.2
p_p	Plastic collapse pressure, see Eq. 5.13
p_{pr}	Propagating pressure, see Eq. 5.16
$p_{pr,A}$	Propagating buckle capacity of infinite buckle arrestor
p_t	System test pressure, see Eq. 4.2 and 5.1
p_x	Crossover pressure, see Eq. 5.18
R	Global bending radius of pipe, Reaction force or Resistance
R_m	Tensile strength
R_{px}	Strength equivalent to a permanent elongation of x% (actual stress)
R_{tx}	Strength equivalent to a total elongation of x% (actual stress)
S	Effective axial force (Tension is positive)
t_c	Characteristic thickness to be replaced by t_1 or t_2 as relevant, see Table 5-6
T	Temperature
t, t_{nom}	Nominal wall thickness of pipe (un-corroded)
T_0	Testing temperature
t_1, t_2	Pipe wall thickness, see Table 5-6
t_{corr}	Corrosion allowance, see Table 5-6
T_c/T_c'	Contingency time for operation/ceasing operation, see Sec.4 C600
t_{fab}	Fabrication thickness tolerance, see Table 7-18
$t_{m,min}$	Measured minimum thickness
T_{max}	Maximum design temperature, see Sec.4 B100

T_{\min}	Minimum design temperature, see Sec.4 B100
t_{\min}	Minimum thickness
T_{pop}	Planned operational period, see Sec.4 C600
T_R/T_R'	Reference period for operation/ceasing operation, see Sec.4 C600
T_{Safe}	Planned time to cease operation, see Sec.4 C600
T_{WF}	Time between generated weather forecasts.
W	Section modulus or Specimen thickness.
W_{sub}	Submerged weight

D 300 Symbols – greek characters

α	Thermal expansion coefficient
α_c	Flow stress parameter, see Eq. 5.22
α_{fab}	Fabrication factor, see Table 5-5
α_{gw}	Girth weld factor (strain resistance), see Eq. 5.30
α_h	$\left(\frac{R_{t0,5}}{R_m} \right)_{\max}$ train hardening
α_{mpt}	Mill pressure test factor, see Table 5-9
α_p	Pressure factor used in combined loading criteria, see Eq. 5.19
α_{pm}	Plastic moment reduction factor for point loads, see Eq. 5.26
α_{spt}	System pressure test factor, see Table 5-9
α_U	Material strength factor, see Table 5-4
β	Factor used in combined loading criteria
ε	Strain
ε_c	Characteristic bending strain resistance, see Eq. 5.30
ε_f	Accumulated plastic strain resistance
$\varepsilon_{l,\text{nom}}$	Total nominal longitudinal strain
ε_p	Plastic strain
ε_r	Residual strain
$\varepsilon_{r,\text{rot}}$	Residual strain limit
γ_A	Load effect factor for accidental load, see Table 4-4
γ_c	Condition load effect factor, see Table 4-5
γ_E	Load effect factor for environmental load, see Table 4-4
γ_ε	Resistance factor, strain resistance, see Table 5-9
γ_F	Load effect factor for functional load, see Table 4-4
γ_{inc}	Incidental to design pressure ratio, see Table 3-1
γ_m	Material resistance factor, see Table 5-2
γ_{rot}	Safety factor for residual strain
γ_{SC}	Safety class resistance factor, see Table 5-3
η	Usage factor
κ	Curvature
ν	Poisson's ratio
μ	Friction coefficient
ρ_{cont}	Density pipeline content
ρ_t	Density pipeline content during system pressure test
σ	Standard deviation of a variable (e.g. thickness)
σ_e	Equivalent stress, Von Mises, see Eq. 5.41
σ_h	Hoop stress, see Eq. 5.42
σ_l	Longitudinal/axial stress, see Eq. 5.43
τ_{lh}	Tangential shear stress

D 400 Subscripts

A	Accidental load
BA	Buckle arrestor
c	Characteristic resistance
d	Design value
E	Environmental load
e	External
el	Elastic
F	Functional load
h	Circumferential direction (hoop direction)
H	Circumferential direction (hoop direction)
i	Internal
L	Axial (longitudinal) direction
M	Moment
mpt	Mill Pressure Test
p	Plastic
R	Radial direction
Rd	Design resistance (i.e. including partial resistance factors)
s	Steel
S	SLS
Sd	Design load (i.e. including load effect factors)
spt	System Pressure Test
U	ULS
X	Crossover (buckle arrestors)

SECTION 2 SAFETY PHILOSOPHY

A. General

A 100 Objective

101 This section presents the overall safety philosophy that shall be applied in the concept development, design, construction, operation and abandonment of pipelines.

A 200 Application

201 This section applies to all submarine pipeline systems which are to be built and operated in accordance with this standard.

202 The integrity of a submarine pipeline system shall be ensured through all phases, from initial concept through to final de-commissioning, see Figure 1. Two integrity stages are defined:

- establish integrity in the concept development, design and construction phases; and
- maintain integrity in the operations phase.

203 This section also provides guidance for extension of this standard in terms of new criteria, etc.

B. Safety Philosophy Structure

B 100 General

101 The integrity of the submarine pipeline system is ensured through a safety philosophy integrating different parts as illustrated in Figure 2.

102 The overall safety principles and the arrangement of safety systems shall be in accordance with DNV-OS-A101 and DNV-OS-E201. See also Sec.3 D.

B 200 Safety objective

201 An overall safety objective shall be established, planned and implemented, covering all phases from conceptual development until abandonment.

Guidance note:

Most companies have a policy regarding human aspects, environment and financial issues. These are typically on an overall level, but may be followed by more detailed objectives and requirements in specific areas. These policies should be used as a basis for defining the Safety Objective for a specific pipeline system. Typical statements may be:

- The impact on the environment shall be reduced to as far as reasonably possible.
- No releases will be accepted during operation of the pipeline system.
- There shall be no serious accidents or loss of life during the construction period.
- The pipeline installation shall not, under any circumstances impose any threat to fishing gear.
- Diverless installation and maintenance.

Statements such as those above may have implications for all or individual phases only. They are typically more relevant for the work execution (i.e. how the Contractor executes his job) and specific design solutions (e.g. burial or no burial). Having defined the Safety Objective, it can be a point of discussion as to whether this is being accomplished in the actual project. It is therefore recommended that the overall Safety Objective be followed up by more specific, measurable requirements.

If no policy is available, or if it is difficult to define the safety objective, one could also start with a risk assessment. The risk assessment could identify all hazards and their consequences, and then enable back-extrapolation to define acceptance criteria and areas that need to be followed up more closely.

The structural failure probability is reflected in the choice of three safety classes (see B400). The choice of safety class should also include consideration of the expressed safety objective.

---e-n-d---of---G-u-i-d-a-n-c-e---n-o-t-e---

Concept		Design		Construction							Operation				Abandonment
Business development	Concept development	Basic design	Detail design	Linepipe	Components and assemblies	Corrosion protection and weight coating	Pre-intervention	Installation	Post-intervention	Pre-commissioning	Commissioning	Integrity management	Inspection and repair	Re-qualification	
2* & 3		4, 5 & 6		7	8	9	10			11					
Establish Integrity											Maintain Integrity				

* indicates Section in this Standard.

Figure 1
Integrity assurance activities during the pipeline system phases



Figure 2
Safety Philosophy structure

B 300 Systematic review of risks

301 A systematic review shall be carried out at all phases to identify and evaluate threats, the consequences of single failures and series of failures in the pipeline system, such that necessary remedial measures can be taken. The extent of the review or analysis shall reflect the criticality of the pipeline system, the criticality of a planned operation, and previous experience with similar systems or operations. The uncertainty in the applied risk review model itself shall also be qualified.

Guidance note:

A methodology for such a systematic review is quantitative risk analysis (QRA). This may provide an estimation of the overall risk to human health and safety, environment and assets and comprises:

- hazard identification
- assessment of probabilities of failure events
- accident developments
- consequence and risk assessment.

The scope of the systematic review should comprise the entire pipeline system, and not just the submarine pipeline system.

It should be noted that legislation in some countries requires risk analysis to be performed, at least at an overall level to identify critical scenarios that might jeopardise the safety and reliability of a pipeline system. Other methodologies for identification of potential hazards are Failure Mode and Effect Analysis (FMEA) and Hazard and Operability studies (HAZOP).

---e-n-d---of---G-u-i-d-a-n-c-e---n-o-t-e---

302 Special attention shall be given to sections close to installations or shore approaches where there is frequent human activity and thus a greater likelihood and consequence of damage to the pipeline. This also includes areas where pipelines are installed parallel to existing pipelines and pipeline crossings.

B 400 Design criteria principles

401 Safety of the pipeline system is ensured by use of a safety class methodology. The pipeline system is classified into one or more safety classes based on failure consequences, normally given by the content and location. For each safety class, a set of partial safety factors is assigned to each limit state.

B 500 Quality assurance

501 The safety format requires that gross errors (human errors) shall be controlled by requirements for organisation of the work, competence of persons performing the work, verification of the design, and quality assurance during all relevant phases.

502 It is assumed that the operator of a pipeline system has established a quality objective. The operator shall, in both internal and external quality related aspects, seek to achieve the quality level of products and services intended in the quality objective. Further, the operator shall provide assurance that intended quality is being, or will be, achieved.

503 Documented quality systems shall be applied by operators and other parties (e.g. design contractors, manufactures, fabricators and installation contractors) to ensure that products, processes and services will be in compliance with the requirements. Effective implementation of quality systems shall be documented.

504 Repeated occurrence of non-conformities reflecting systematic deviations from procedures and/or inadequate workmanship shall initiate:

- investigation into the causes of the non-conformities
- reassessment of the quality system
- corrective action to establish possible acceptability of products
- preventative action to prevent re-occurrence of similar non-conformities.

Guidance note:

ISO 9000 give guidance on the selection and use of quality systems.

---e-n-d---of---G-u-i-d-a-n-c-e---n-o-t-e---

505 Quality surveillance in the construction phase shall be performed by the operator or an inspectorate nominated by the operator. The extent of quality surveillance shall be sufficient to establish that specified requirements are fulfilled and that the intended quality level is maintained.

506 To ensure safety during operations phase, an integrity management system in accordance with Sec.11 C shall be established and maintained.

B 600 Health, safety and environment

601 The concept development, design, construction, operation and abandonment of the pipeline system shall be conducted in compliance with national legislation and company policy with respect to health, safety and environmental aspects.

602 The selection of materials and processes shall be conducted with due regard to the safety of the public and employees and to the protection of the environment.

C. Risk Basis for Design

C 100 General

101 The design format is based upon a limit state and partial safety factor methodology, also called Load and Resistance Factor Design format (LRFD). The load and resistance factors depend on the safety class, which characterizes the consequences of failure.

C 200 Categorisation of fluids

201 Fluids to be transported by the pipeline system shall be categorised according to their hazard potential as given by Table 2-1.

Category	Description
A	Typical non-flammable water-based fluids.
B	Flammable and/or toxic fluids which are liquids at ambient temperature and atmospheric pressure conditions. Typical examples are oil and petroleum products. Methanol is an example of a flammable and toxic fluid.
C	Non-flammable fluids which are non-toxic gases at ambient temperature and atmospheric pressure conditions. Typical examples are nitrogen, carbon dioxide, argon and air.
D	Non-toxic, single-phase natural gas.
E	Flammable and/or toxic fluids which are gases at ambient temperature and atmospheric pressure conditions and which are conveyed as gases and/or liquids. Typical examples would be hydrogen, natural gas (not otherwise covered under category D), ethane, ethylene, liquefied petroleum gas (such as propane and butane), natural gas liquids, ammonia, and chlorine.

Guidance note:

It is recommended to categorize CO₂ pipelines as more severe by Category E unless long operational experience exist by the operator of CO₂ pipeline of similar composition and operated in similar manner. Recommended practice for pipelines conveying CO₂ is given in DNV-RP-J202.

---e-n-d---of---G-u-i-d-a-n-c-e---n-o-t-e---

202 Gases or liquids not specifically identified in Table 2-1 should be classified in the category containing fluids most similar in hazard potential to those quoted. If the fluid category is not clear, the most hazardous category shall be assumed.

C 300 Location classes

301 The pipeline system shall be classified into location classes as defined in Table 2-2.

Location	Definition
1	The area where no frequent human activity is anticipated along the pipeline route.
2	The part of the pipeline/riser in the near platform (manned) area or in areas with frequent human activity. The extent of location class 2 should be based on appropriate risk analyses. If no such analyses are performed a minimum horizontal distance of 500 m shall be adopted.

C 400 Safety classes

401 Pipeline design shall be based on potential failure consequence. This is implicit by the concept of safety class. The safety class may vary for different phases and locations. The safety classes are defined in Table 2-3.

Safety class	Definition
Low	Where failure implies insignificant risk of human injury and minor environmental and economic consequences
Medium	Where failure implies low risk of human injury, minor environmental pollution or high economic or political consequences.
High	Classification for operating conditions where failure implies risk of human injury, significant environmental pollution or very high economic or political consequences

402 The partial safety factors related to the safety class are given in Sec.5 C200.

403 For normal use, the safety classes in Table 2-4 apply:

Phase	Fluid Category A, C		Fluid Category B, D and E	
	Location Class		Location Class	
	1	2	1	2
Temporary ^{2,3}	Low	Low	-	-
Operational	Low	Medium ⁴	Medium	High

1) Other classifications may exist depending on the conditions and criticality of failure the pipeline. For pipelines where some consequences are more severe than normal, i.e. when the table above does not apply, the selection of a higher safety class shall also consider the implication, on the total gained safety. If the total safety increase is marginal, the selection of a higher safety class may not be justified.

2) Installation until pre-commissioning (temporary phase) will normally be classified as safety class Low.

3) For safety classification of temporary phases after commissioning, special consideration shall be made to the consequences of failure, i.e. giving a higher safety class than Low.

4) Risers during normal operation will normally be classified as safety class High.

C 500 Reliability analysis

501 As an alternative to the specific LRFD (and ASD) format, a recognised structural reliability analysis (SRA) based design method may be applied provided that:

- the method complies with DNV Classification Note no. 30.6 “*Structural reliability analysis of marine structures*”
- the approach is demonstrated to provide adequate safety for familiar cases, as indicated by this standard.

Reliability based limit state design shall not be used to replace the safety factors for pressure containment criterion in Sec.5 with the exception of accidental pressure. Accidental limit states shall be designed based on SRA in line with Sec.5 D1000 ensuring that the overall nominal failure probability complies with the nominal failure probability target values in this sub-section.

502 Suitably competent and qualified personnel shall perform the structural reliability analysis, and extension into new areas of application shall be supported by technical verification.

503 As far as possible, nominal target failure probability levels shall be calibrated against identical or similar pipeline designs that are known to have adequate safety on the basis of this standard. If this is not feasible, the nominal target failure probability level shall be based on the failure type and safety class as given in Table 2-5.

Limit State Category	Limit State	Safety Classes			
		Low	Medium	High	Very High ⁴⁾
SLS	All	10 ⁻²	10 ⁻³	10 ⁻³	10 ⁻⁴
ULS	Pressure Containment ¹⁾	10 ⁻⁴ to 10 ⁻⁵	10 ⁻⁵ to 10 ⁻⁶	10 ⁻⁶ to 10 ⁻⁷	10 ⁻⁷ to 10 ⁻⁸
ALS					
ULS	All other	10 ⁻³	10 ⁻⁴	10 ⁻⁵	10 ⁻⁶
FLS ²⁾					
ALS ³⁾					

1) The failure probability for the pressure containment (wall thickness design) is one to two order of magnitudes lower than the general ULS criterion given in the Table, in accordance with industry practice and reflected by the ISO requirements.
 2) The failure probability will effectively be governed by the last year in operation or prior to inspection depending on the adopted inspection philosophy.
 3) Nominal target failure probabilities can alternatively be one order of magnitude less (e.g. 10⁻⁴ per pipeline to 10⁻⁵ per km) for any running km if the consequences are local and caused by local factors.
 4) See Appendix F Table F-2.
 5) The target shall be interpret as “probability that a failure occurs in the period of one year”.

Guidance note:

Local factors and associated consequences may be e.g. shipping lanes.

---e-n-d---of---G-u-i-d-a-n-c-e---n-o-t-e---

SECTION 3

CONCEPT AND DESIGN PREMISE DEVELOPMENT

A. General

A 100 Objective

101 This section identifies and provides a basis for definition of relevant field development characteristics. Further, key issues required for design, construction, operation, and abandonment of the submarine pipeline system are identified.

A 200 Application

201 This section applies to submarine pipeline systems which are to be built according to this standard.

202 The design premises outlined in this section should be developed during the conceptual phase and reviewed and updated when found necessary.

A 300 Systematic review

301 The overall requirement to systematic review in Sec.2 shall be reflected in the concept evaluation.

302 Threats identified may typically have impacts on cost, schedule and performance, and may include:

- Scope changes (flow characteristics, throughputs, maturity of technical solutions)
- Market factors and prices (material, equipment, contractors)
- Severe weather conditions (delays to marine operations due to limiting weather conditions)
- Contractor availability and performance (cost, construction delays, quality)
- Supply and quality of material (delays, performance)
- Availability and cost of financing (delays, commercial feasibility)
- Constructability (limited access for installation vessels, simultaneous operations with other installation activities, vessel capacity and deck space)
- Novel technology.

303 Threat identification for the Society / Safety report

- Environmental impact
- Impact on other industries
- Safety of life.

304 Threats identification on the pipeline may include:

- Environment
- Third party activities
- Geo-hazards
- Flow constraints.

305 Impacts of the identified threats on operation of the submarine pipeline system shall be evaluated.

B. Concept Development

B 100 Concept development

101 When selecting the submarine pipeline system concept all aspects related to design, construction, operation and abandonment shall be considered. Due account should be given to identification of potential aspects which can stop the concept from being realised:

- long lead effects of early stage decisions (e.g. choice of material grade may affect manufacturing aspects of linepipe, choice of diameter may give restrictions to installation methods etc.)
- life cycle evaluations (e.g. maintenance activities etc.)
- installation aspects for remote areas (e.g. non-availability of major installation equipment or services and weather issues).

102 Data and description of field development and general arrangement of the pipeline system shall be established.

103 The data and description should include the following, as applicable:

- safety objective
- environmental objective
- location, inlet and outlet conditions

- pipeline system description with general arrangement and battery limits
- functional requirements including field development restrictions, e.g., safety barriers and subsea valves
- installation, repair and replacement of pipeline elements, valves, actuators and fittings
- project plans and schedule, including planned period of the year for installation
- design life including specification for start of design life, e.g. final commissioning, installation etc.
- data of product to be transported including possible changes during the pipeline system's design life
- transport capacity and flow assurance
- pipeline safety system requirements including process system layout and incidental to design pressure ratio evaluations
- pipeline sizing data
- attention to possible code breaks in the pipeline system
- geometrical restrictions such as specifications of constant internal diameter, requirement for fittings, valves, flanges and the use of flexible pipe or risers
- relevant pigging scenarios (inspection and cleaning)
- pigging fluids to be used and handling of pigging fluids in both ends of pipeline including impact on process systems
- pigging requirements such as bend radius, pipe ovality and distances between various fittings affecting design for pigging applications
- sand production
- second and third party activities
- restricted access for installation or other activities due to presence of ice.

104 An execution plan should be developed, including the following topics:

- general information, including project organisation, scope of work, interfaces and project development phases
- contacts with Purchaser, authorities, third party, engineering, verification and construction Contractors
- legal aspects, e.g. insurance, contracts, area planning, requirements to vessels.

105 The design and planning for the submarine pipeline system should cover all development phases including construction, operation and abandonment.

C. Design Premise

C 100 Hydraulic analyses and flow assurance

101 Hydraulic analyses of the pipeline systems should be performed to determine the required diameter and pressure to meet the transport capacity requirement.

102 A parameter safety envelope (.e.g. pressure, temperature, content composition) shall be determined. The hydraulics of the pipeline system should be analysed to demonstrate that the pipeline system can safely transport the fluids within this parameter safety envelope. This shall include identification of constraints and requirements for its operation. This analysis should cover steady-state and transient operating conditions.

Guidance note 1:

Examples of constraints and operational requirements are allowances for pressure surges, prevention of blockage such as caused by the formation of hydrates and wax deposition, measures to prevent unacceptable pressure losses from higher viscosities at lower operation temperatures, measures for the control of liquid slug volumes in multi-phase fluid transport, flow regime for internal corrosion control erosional velocities and avoidance of slack line operations. It includes requirements to insulation, maximum shut-down times, requirements for heating etc. as well as description of pressure designing cases (e.g. preservation cases with methanol) with associated temperatures.

---e-n-d---of---G-u-i-d-a-n-c-e---n-o-t-e---

Guidance note 2:

The parameter safety envelope shall also include minimum values if applicable. Examples of this may be minimum required pressures for pipeline systems that not are designed for the fully external over pressure.

---e-n-d---of---G-u-i-d-a-n-c-e---n-o-t-e---

103 The hydraulics of the pipeline system shall be analysed to demonstrate that the Pipeline Control System and Pipeline Safety System meet its requirement during start-up, normal operation, shut-down (e.g. closing of valves) and all foreseen non-intended scenarios. This shall also include determination of required incidental to design pressure ratio.

104 The hydraulic analyses shall be used to determine the characteristic high design temperature profile based on conservative insulation values reflecting the variation in insulation properties of coatings and surrounding seawater, soil and gravel.

105 The hydraulic analyses shall be used to determine the characteristic low design temperature. Benefit of specifying low temperatures locally due to e.g. opening of valves is allowed and shall be documented e.g. by hydraulic analyses.

C 200 Environmental condition

201 Environmental phenomena that might impair proper functioning of the system or cause a reduction of the reliability and safety of the system shall be considered, including:

- wind
- tide
- waves
- internal waves and other effects due to differences in water density
- current
- ice
- earthquake
- soil conditions
- temperature
- marine growth (fouling).

202 Recommended practice for principles and methodologies for establishing environmental conditions and loads is given in DNV-RP-C205.

C 300 Collection of environmental data

301 The environmental data shall be representative for the geographical areas in which the pipeline system is to be installed. If sufficient data are not available for the geographical location in question, conservative estimates based on data from other relevant locations may be used.

302 Statistical data shall be utilised to describe environmental parameters of a random nature (e.g. wind, waves). The parameters shall be derived in a statistically valid manner using recognised methods.

303 For the assessment of environmental conditions along the pipeline route, the pipeline may be divided into a number of sections, each of which is characterised by a given water depth, bottom topography and other factors affecting the environmental conditions.

304 The environmental data to be used in the design of the submarine pipeline system which is connected to an offshore structure or routed near an offshore structure are in principle the same as the environmental data used in the design of the offshore structure.

C 400 Environmental data

401 The estimated maximum tide shall include both astronomic tide and storm surge. Minimum tide estimates should be based upon the astronomic tide and possible negative storm surge.

402 All relevant sources to current shall be considered. This may include tidal current, wind induced current, storm surge current, density induced current or other possible phenomena. For near-shore regions, long-shore current due to wave breaking shall be considered. Variations in magnitude with respect to direction and water depth shall be considered when relevant.

403 In areas where ice may develop or where ice bergs may pass or where the soil may freeze sufficient statistics shall be established in order to enable calculations of relevant loads.

404 Air and sea temperature statistics shall be provided giving representative high and low design values.

405 Marine growth on pipeline systems shall be considered, taking into account both biological and other environmental phenomena relevant for the location.

C 500 Pipeline route

501 The pipeline route shall be selected with due regard to safety of the public and personnel, protection of the environment, and the probability of damage to the pipe or other facilities. Agreement with relevant parties should be sought as early as possible. Factors to take into consideration shall, at minimum, include the following:

Environment

- archaeological sites
- exposure to environmental damage
- areas of natural conservation interest such as oyster beds and coral reefs
- marine parks
- turbidity flows.

Seabed characteristics

- uneven seabed
- unstable seabed
- soil properties (hard spots, soft sediment and sediment transport)
- subsidence
- seismic activity.

Facilities

- offshore installations
- subsea structures and well heads
- existing pipelines and cables
- obstructions
- coastal protection works.

Third party activities

- ship traffic
- fishing activity
- dumping areas for waste, ammunition, etc.
- mining activities
- military exercise areas.

Landfall

- local constraints
- 3rd party requirements
- environmental sensitive areas
- vicinity to people
- limited construction period.

502 Expected future marine operations and anticipated developments in the vicinity of the pipeline shall be considered when selecting the pipeline route.

503 In-line assemblies should not be located on the curved route sections of the pipeline.

Guidance note:

It is preferred to have a sagbend length of straight section after a curve before the in-line assembly because of potential rotation.

---e-n-d---of---G-u-i-d-a-n-c-e---n-o-t-e---

504 Pipeline ends should be designed with a reasonable straight length ahead of the target boxes. Curvatures near pipeline ends should be designed with due regard to end terminations, lay method, lay direction and existing/planned infrastructure.

C 600 Route survey

601 Surveys shall be carried out along the total length of the planned pipeline route to provide sufficient data for design and construction related activities.

602 The survey corridor shall have sufficient width to define an installation and pipeline corridor which will ensure safe installation and operation of the pipeline.

603 The required survey accuracy may vary along the proposed route. Obstructions, highly varied seabed topography, or unusually or hazardous sub-surface conditions may dictate more detailed investigations. The survey accuracy shall be sufficient for performing the design, construction and operation activities in a safe manner.

604 Investigations to identify possible conflicts with existing and planned installations and possible wrecks and obstructions shall be performed. Examples of such installations include other submarine pipelines, and power and communication cables.

605 The results of surveys shall be presented on accurate route maps and alignments, scale commensurate with required use. Location of the pipeline, related facilities together with seabed properties, anomalies and all relevant pipeline attributes shall be shown. Reference seawater elevation shall be defined.

606 Additional route surveys may be required at landfalls to determine:

- seabed geology and topography specific to landfall and coastal environment
- environmental conditions caused by adjacent coastal features
- location of the landfall to facilitate installation
- facilitate pre or post installation seabed intervention works specific to landfall, such as trenching
- location to minimise environmental impact.

607 All topographical features which may influence the stability and installation or influence seabed intervention of the pipeline shall be covered by the route survey, including:

- obstructions in the form of rock outcrops, large boulders, pock marks, etc., that could necessitate remedial, levelling or removal operations to be carried out prior to pipeline installation
- topographical features that contain potentially unstable slopes, sand waves, pock marks or significant depressions, valley or channelling and erosion in the form of scour patterns or material deposits.

608 Areas where there is evidence of increased geological activity or significant historic events that if re-occurring again may impact the pipeline, additional geohazard studies should be performed. Such studies may include:

- extended geophysical survey
- mud volcanoes or pockmark activity
- seismic hazard
- seismic fault displacements
- possibility of soil slope failure
- mudflow characteristics
- mudflow impact on pipelines.

C 700 Seabed properties

701 Geotechnical characteristics necessary for evaluating the effects of relevant loading conditions shall be determined for the seabed deposits, including possible unstable deposits in the vicinity of the pipeline. For guidance on soil investigation for pipelines, reference is made to Classification Note No. 30.4 “Foundations”.

702 Geotechnical properties may be obtained from generally available geological information, results from seismic surveys, seabed topographical surveys, and geotechnical in-situ tests and laboratory tests on sampled soil. Supplementary information may be obtained from visual surveys or special tests, as e.g. pipe penetration tests.

703 Soil parameters of main importance for the pipeline response are:

- shear strength parameters (intact and remoulded undrained shear strength for clay, and angle of friction for sands); and
- relevant deformation characteristics.

These parameters should preferably be determined from adequate laboratory tests or from interpretation of in-situ tests. In addition, classification and index tests should be considered, such as:

- unit weight
- water content
- liquid and plastic limit
- grain size distribution
- carbonate content
- other relevant tests.

704 It is primarily the characteristics of the upper layer of soil that determine the response of the pipeline resting on the seabed. The determination of soil parameters for these very shallow soils may be relatively more uncertain than for deeper soils. Also the variations of the top soil between soil testing locations and between tested locations and non-tested locations add to the uncertainty. Soil parameters used in the design may therefore need to be defined with upper bound, best estimate and lower bound limits valid within defined areas or sections of the route. The characteristic value(s) of the soil parameter(s) used in the design shall be in line with the selected design philosophy accounting for these uncertainties.

Guidance note:

For deep water areas the upper layer may be slurry with a very small strength. In these cases emphasis should also be made to the soil layer underneath.

---e-n-d---of---G-u-i-d-a-n-c-e---n-o-t-e---

705 Since the distance between soil investigations is often much larger than the length of pipe involved in a particular design situation, one will in such circumstances have to assume that the soil characteristics for the design situation is the worst of high and low estimates obtained from relevant available soil investigation data related to the entire route or to a defined section of the route.

706 In areas where the seabed material may be subjected to erosion, special studies of the current and wave conditions near the bottom including boundary layer effects may be required for the on-bottom stability calculations of pipelines and the assessment of pipeline spans.

707 Additional investigation of the seabed material may be required to evaluate specific scenarios, as for example:

- challenges with respect to excavation and burial operations
- probability of forming free-pans caused by scouring during operational phase
- challenges with respect to pipeline crossing
- challenges with the settlement of pipeline system and/or the protection structure at the valve/tee locations
- possibilities of mud slides or liquefaction as the result of repeated loading
- implications for external corrosion.

D. System Design Principles

D 100 System integrity

101 The pipeline system shall be designed, constructed and operated in such a manner that:

- the specified transport capacity is fulfilled and the flow assured
- the defined safety objective is fulfilled and the resistance against loads during planned operational conditions is sufficient
- the safety margin against accidental loads or unplanned operational conditions is sufficient.
- system layout, including needs for different valves etc., meets the requirements imposed by the systematic review of the process control.

102 Pipelines in C-Mn steel for potentially corrosive fluids of categories B, D and E (see Sec.2 C) should be designed for inspection pigging. In cases where the pipeline design does not allow inspection pigging, an analysis shall be carried out in accordance with recognised procedures to document that the risk of failure leading to a leak is acceptable. For corrosive fluids of other categories the benefit of inspection pigging on operational reliability shall be evaluated.

103 The need for in-line cleaning and/or inspection, involving the presence of appropriate pig launcher / receiver should be determined in the design phase.

104 The possibility of changes in the type or composition of fluid to be transported during the lifetime of the pipeline system shall be assessed in the design phase.

105 Any re-qualification deemed necessary due to changes in the design conditions shall take place in accordance with provisions set out in Sec.11.

D 200 Pipeline control and safety system

201 The incidental pressure is defined as having an annual probability of exceedance less than 10^{-2} (a probability of being exceeded within a year). If the pressure probability density function does not have a monotonic decay beyond 10^{-2} the pressure exceeding the incidental pressure shall be checked as accidental loads in compliance with Sec.5 D1000.

Guidance note 1:

Examples of pressure probability density distributions are given in Figure 1. An example of a pipeline system with a two peak distribution may be a pipeline system protected by a HIPP system.

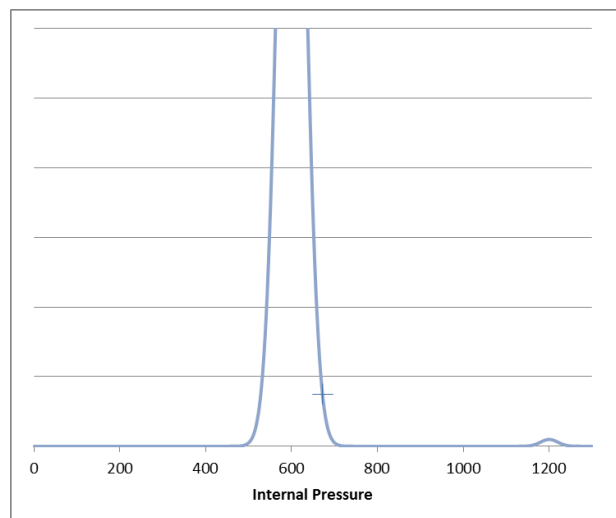

Figure 1
Pressure distribution function with two peak distribution

The 100-year value, the incidental pressure (see mark in Figure 1), will be used for normal design for both two peak distributions and single peak distributions. For two peak distributions the second peak pressure shall also be checked for accidental limit state in accordance with Sec.5 D1000 (see pressure of 1200 in Figure 1).

---e-n-d---of---G-u-i-d-a-n-c-e---n-o-t-e---

Guidance note 2:

When the submarine pipeline system is connected to another system with different pressure definition the pressure values may be different in order to comply with the requirements of this sub-section, i.e. the design pressure may be

different in two connected systems. The conversion between the two system definitions will often then be based on that the incidental pressures are equal.

---e-n-d---of---G-u-i-d-a-n-c-e---n-o-t-e---

202 The submarine pipeline system shall have a specified incidental pressure or be split into different sections with different specified incidental pressures. These should all be defined at a defined reference elevation.

203 To fulfil the requirements in 201 and 202 a Pipeline Control and Safety System may be required. This comprises the Pipeline Control System (PCS) and Pipeline Safety System (PSS).

Guidance note:

An example of situations where a Pipeline Control and Safety System may not be required is if full shut-in pressure including dynamic effects, is used as incidental pressure.

---e-n-d---of---G-u-i-d-a-n-c-e---n-o-t-e---

204 The purpose of the Pipeline Control System is to maintain the operating parameters within operating envelope during normal operation e.g. to ensure that the local design pressure is not exceeded at any point in the submarine pipeline system. The Pipeline Control System should operate automatically. Due account shall be given to the tolerances of the pipeline control system and its associated instrumentation, see Figure 1 in Sec.1. Hence, the maximum allowable operating pressure (MAOP) is equal to the design pressure minus the Pipeline Control System operating tolerance.

205 The Pipeline Control System could be included as a risk reducing measure provided that this system is independent of PSS and further complies with the following:

- The Pipeline Control System is not included as a part of the demand rate defined for the PSS
- Failure of an automatic pipeline control system shall not affect the alarm system needed for human intervention.
- Maximum risk reduction (PFD) taken is less than 10^{-1} unless the PCS is built in accordance with safety system standards, e.g., IEC61511.
- Risk reduction from human intervention, in addition to PCS, assumes that actions are based upon information from systems independent of PCS and PSS. The sum of Human Intervention and PCS risk reduction shall then not be less than 10^{-2} .

206 The purpose of the Pipeline Safety System is to protect the submarine pipeline system by limiting the operating parameters within the parameter safety envelope during incidental operation, e.g. to ensure that the local incidental pressure is not exceeded at any point in the pipeline system in the event of failure of the pipeline control system. The Pipeline Safety System shall operate automatically. Due account shall be given to the tolerances of the pipeline safety system. Hence, the maximum allowable incidental pressure is equal to the incidental pressure minus the pipeline safety system operating tolerance.

207 The Pipeline Control System is a basic process control system as defined by IEC 61511. The Pipeline Safety shall comply with the requirements of IEC 61511. Pipeline Safety Systems required with a probability of failure on demand of less than 10^{-3} shall consist of two independent systems.

Guidance note:

The requirements for the level of risk reduction to be provided by the pipeline safety system, the SIL Level shall be derived according to the requirements of Sec.5 D1000 and not from a risk assessment. Sec.13 E600 provides further guidance.

---e-n-d---of---G-u-i-d-a-n-c-e---n-o-t-e---

208 The Pipeline Safety System may consist of pressure relief devices (ISO 4126) and/or safety instrumented systems, see IEC 61511. Pressure relief valves are considered fulfilling requirements to the Pipeline Safety System if these are designed and maintained to relieve the required discharge capacity at a pressure not exceeding the maximum allowable incidental pressure.

209 A design pressure may be defined for each incidental pressure. The incidental to design pressure ratio shall be selected such that the Pipeline Control and Safety System meet the requirements in 201 and 202. Typical and minimum incidental to design ratios are given in Table 3-1. When design pressure is used for structural design purpose, this shall be minimum 91% of the incidental pressure.

Table 3-1 Incidental to design pressure ratios	
Condition or pipeline system	γ_{inc}
Typical pipeline system	1.10
Minimum, except for below	1.05
When design pressure is equal to full shut-in pressure including dynamic effects	1.00

Guidance note:

This standard use incidental pressure in all limit states. Other referenced codes (e.g. for components) may use design pressure instead. For such applications, the design pressure shall be the higher of p_{li}/γ_{inc} and $0.91 \cdot p_{li}$. For pipeline systems conveying liquids particular attention shall be given to dynamic effects and pump characteristics when determining the incidental pressure.

---e-n-d---of---G-u-i-d-a-n-c-e---n-o-t-e---

D 300 External corrosion control

301 For the selection and detailed design of external corrosion control, the following conditions relating to the environment shall be defined, in addition to those mentioned in C201:

- exposure conditions, e.g. burial, rock dumping, etc.
- sea water and sediment resistivity.

302 Other conditions affecting external corrosion which shall be defined are:

- temperature profiles (e.g. average, characteristic high design) along the pipeline and through the pipe wall thickness
- pipeline fabrication and installation procedures
- requirements for mechanical protection, submerged weight and thermal insulation during operation
- design life
- selected coating and cathodic protection system.

303 Special attention should be given to the landfall section (if any) and interaction with relevant cathodic protection system for onshore vs. offshore pipeline sections.

304 The impact on the external pipe condition of the third party activities as mentioned in C501 should be considered.

D 400 Internal construction conditions

401 A description of the internal pipe conditions during construction phase shall be prepared (this includes storage, construction, installation, pressure testing and commissioning). The duration of exposure to sea water or humid air, and the need for using inhibitors or other measures to control corrosion shall be considered.

D 500 Internal corrosion control

501 In order to assess the need for internal corrosion control, including corrosion allowance and provision for inspection and monitoring, the following conditions shall be defined:

- operating temperature/pressure profiles along the pipeline including expected variations during the design life
- flow velocity and flow regime
- fluid composition (initial and anticipated variations during the design life) with emphasis on potentially corrosive components (e.g. hydrogen sulphide, carbon dioxide, water content and expected content of dissolved salts in produced fluids, residual oxygen and active chlorine in sea water)
- chemical additions and provisions for periodic cleaning
- provision for inspection of corrosion damage and expected capabilities of inspection tools (i.e. detection limits and sizing capabilities for relevant forms of corrosion damage)
- the possibility of erosion by any solid particles in the fluid shall be considered. Recommended practice for erosive wear in piping systems is given in DNV-RP-O501.

SECTION 4 **DESIGN - LOADS**

A. General

A 100 Objective

101 This section defines the loads to be checked by the limit states in Sec.5. This includes:

- load scenarios
- categorisation of loads
- design load effects
- characteristic load
- load effect factor combinations
- load effect calculations.

A 200 Application

201 This section applies to all parts of the submarine pipeline system.

A 300 Systematic review

301 The overall requirement to systematic review in Sec.2 will for this section imply a review of loads based on their uncertainty and importance for the different limit states.

A 400 Load scenarios

401 All loads and forced displacements which may influence the pipeline shall be taken into account. For each cross section or part of the system to be considered and for each possible mode of failure to be analysed, all relevant combinations of loads which may act simultaneously shall be considered.

402 The most unfavourable load scenario for all relevant phases and conditions shall be considered. Typical scenarios to be covered in the design are:

- transportation
- installation
- as laid
- water filled
- system pressure test
- operation
- shut-down.

A 500 Categorisation of loads

501 The objective of the categorisation of loads into the different load categories is to relate the load effect to the associated uncertainties.

502 Unless the load is categorised as accidental it shall be categorised as:

- functional load,
- environmental load, or
- interference load.

The load categories are described in B, C and E below. Construction loads shall be categorised into the above loads and are described in D. Accidental loads are described in F.

A 600 Design load effects

601 The design load effect calculations are given in G.

B. Functional Loads

B 100 General

101 Loads arising from the physical existence of the pipeline system and its intended use shall be classified as functional loads.

102 Effects from the following phenomena are the minimum to be considered when establishing functional loads:

- Weight
- reactions from installation vessel (tensioners, straightener, Stinger/rollers)
- external hydrostatic pressure

- static hydrodynamic forces during installation
- reactions from soil in sag bend
- internal pressure
- temperature of contents
- pre-stressing
- reactions from components (flanges, clamps etc.)
- permanent deformation of supporting structure
- cover (e.g. soil, rock, mattresses, culverts)
- reaction from seabed (friction and rotational stiffness)
- permanent deformations due to subsidence of ground, both vertical and horizontal
- permanent deformations due to frost heave
- changed axial friction due to freezing
- possible loads due to ice interference, e.g. bulb growth around buried pipelines near fixed points (in-line valves/tees, fixed plants etc.), drifting ice etc.
- loads induced by pigging operations.

103 The weight shall include weight of pipe, buoyancy, contents, coating, anodes, marine growth and all attachments to the pipe.

104 End cap forces due to pressure shall be considered, as well as any transient pressure effects during normal operation (e.g. due to closure of valves).

105 Temperature due to internal fluid and external environmental shall be determined and corresponding temperature profiles for the following scenarios:

- The maximum and minimum design (100-year return values) temperature during operation
- Representative temperatures during operation
- Representative temperatures during installation, as-laid, water filled and system pressure test.

Guidance note:

The temperature is normally determined for the pipe steel (to be used for structural purpose) but may also be required for anodes, coating etc.

The selection of design or operational temperature is given by Table 4-3.

---e-n-d---of---G-u-i-d-a-n-c-e---n-o-t-e---

106 Local minimum temperature profiles, which may be caused by e.g. sudden shut-downs, may be applied. This will typically be relevant to defined components and sections of the pipeline (e.g. spots around valves).

107 Fluctuations in temperature shall be taken into account when checking fatigue strength.

108 For expansion analyses, the temperature difference relative to laying shall be considered. The temperature profile shall be applied.

109 Pre-stressing, such as permanent curvature or a permanent elongation introduced during installation, shall be taken into account if the capacity to carry other loads is affected by the pre-stressing. Pretension forces induced by bolts in flanges, connectors and riser supports and other permanent attachments, shall be classified as functional loads.

110 The soil pressure acting on buried pipelines shall be taken into account if significant.

B 200 Internal pressure loads

201 The following internal pressures shall be defined at a certain defined reference level; system test pressure, operating pressure (if relevant), design pressure (if applicable), and incidental pressure, see Sec.3 D200 for definitions and Figure 1 in Sec.1. These pressures are summarised in Table 4-1.

<i>Pressure</i>	<i>Abbreviations</i>	<i>Symbol</i>	<i>Description</i>
Mill test	-	P_h	Hydrostatic test pressure at the mill, see Sec.7 E.
System test	-	P_t	The pressure to which the complete submarine pipeline system is tested to prior to commissioning, see Sec.5 B200.
Incidental	-	P_{inc}	Maximum pressure (100-year value) the submarine pipeline system is designed to withstand, see Sec.3 D200.
Maximum allowable incidental	MAIP	-	Maximum allowable incidental pressure is equal to the incidental pressure minus the pipeline safety system (PSS) operating tolerance.
Design	-	P_D	The maximum pressure during normal operation that the pipeline control system (PCS) allows.
Maximum allowable operating	MAOP	-	Maximum allowable operating pressure is equal to the design pressure minus the pipeline control system (PCS) operating tolerance, and is hence the upper limit of the pipeline control system.

Guidance note:

The incidental pressure is defined in terms of exceedance probability within a year. The ratio between the incidental pressure and the design pressure, see Table 3-1, is determined by the accuracy and speed of the pipeline safety system. When the pressure source is given (e.g. well head shut-in pressure) this may constitute the selection of the incidental pressure. The design pressure can then be established based on the pipeline safety system. When transport capacity requirement constitute the design premise this may give the design pressure and the incidental pressure can then be established based on the pipeline safety system.

---e-n-d---of---G-u-i-d-a-n-c-e---n-o-t-e---

202 The local pressure is the internal pressure at a specific point based on the reference pressure adjusted for the fluid column weight due to the difference in elevation. It can be expressed as:

$$p_{li} = p_{inc} + \rho_{cont} \cdot g \cdot (h_{ref} - h_l) \quad (4.1)$$

$$p_{lt} = p_t + \rho_t \cdot g \cdot (h_{ref} - h_l) \quad (4.2)$$

$$p_{inc} = p_d \cdot \gamma_{inc} \quad (4.3)$$

where

- p_{li} is the local incidental pressure
- p_{inc} is the incidental reference pressure at the reference elevation
- ρ_{cont} is the density of the relevant content of the pipeline
- g is the gravity
- h_{ref} is the elevation of the reference point (positive upwards)
- h_l is the elevation of the local pressure point (positive upwards)
- p_{lt} is the local system test pressure
- p_t is the system test reference pressure at the reference elevation
- ρ_t is the density of the relevant test medium of the pipeline
- p_d is the design pressure at the pressure reference elevation
- γ_{inc} is the incidental to design pressure ratio

203 In cases where external pressure increases the capacity, the external pressure shall not be taken as higher than the water pressure at the considered location corresponding to low astronomic tide including possible negative storm surge.

204 In cases where the external pressure decreases the capacity, the external pressure shall not be taken as less than the water pressure at the considered location corresponding to high astronomic tide including storm surge.

C. Environmental Loads

C 100 General

101 Environmental loads are defined as those loads on the pipeline system which are caused by the surrounding environment, and that are not otherwise classified as functional or accidental loads.

102 Recommended practice for calculation of characteristic environmental loads is given in DNV-RP-C205.

C 200 Wind loads

201 Wind loads shall be determined using recognised theoretical principles. Alternatively, direct application of data from adequate tests may be used.

202 The possibility of vibrations and instability due to wind induced cyclic loads shall be considered (e.g. vortex shedding).

C 300 Hydrodynamic loads

301 Hydrodynamic loads are defined as flow-induced loads caused by the relative motion between the pipe and the surrounding water.

302 All relevant sources for hydrodynamic loads shall be considered. This may include waves, current, and relative pipe motions and indirect forces e.g. caused by vessel motions.

303 The following hydrodynamic loads shall be considered:

- drag and lift forces which are in phase with the absolute or relative water particle velocity
- inertia forces which are in phase with the absolute or relative water particle acceleration
- flow-induced cyclic loads due to vortex shedding, galloping and other instability phenomena

- impact loads due to wave slamming and slapping, and
- buoyancy variations due to wave action.

Guidance note:

Recent research into the hydrodynamic coefficients for open bundles and piggy-back lines indicates that the equivalent diameter approach may be nonconservative, and a system specific computational fluid dynamics (CFD) analysis may be required to have a robust design.

---e-n-d---of---G-u-i-d-a-n-c-e---n-o-t-e---

304 The applied wave theory shall be capable of describing the wave kinematics at the particular water depth in question including surf zones hydrodynamics where applicable. The suitability of the selected theory shall be demonstrated and documented.

305 The current-induced drag and lift forces on the submarine pipeline system shall be determined and combined with the wave-induced forces using recognised theories for wave-current interaction. A vector combination of the current and wave-induced water particle velocities may be used, however, calculation of the total particle velocities and accelerations based upon more exact theories on wave-current interaction is preferable.

306 Data from model testing or acknowledged industry practice may be used in the determination of the relevant hydrodynamic coefficients.

307 Consideration shall be given to wave direction, short crested waves, wave refraction and shoaling, shielding and reflecting effects.

308 Variations in current velocity magnitude and direction as a function of water depth shall be considered.

309 Where parts of the pipeline system are positioned adjacent to other structural parts, possible effects due to disturbance of the flow field shall be considered when determining the wave and/or current actions. Such effects may cause an increased or reduced velocity, or dynamic excitation by vortices being shed from the adjacent structural parts.

310 If parts of the submarine pipeline system is built up of a number of closely spaced pipes, then interaction and solidification effects shall be taken into account when determining the mass and drag coefficients for each individual pipe or for the whole bundle of pipes. If sufficient data is not available, large-scale model tests may be required.

311 For pipelines on or close to a fixed boundary (e.g. pipeline spans) or in the free stream (e.g. risers), lift forces perpendicular to the axis of the pipe and perpendicular to the velocity vector shall be taken into account (possible vortex induced vibrations).

312 In connection with vortex shedding-induced transverse vibrations, potential increase in drag coefficient shall be taken into account.

313 Possible increased waves and current loads due to presence of Tee's, Y's or other attachments shall be considered.

314 The effect of possible wave and current loading on the submarine pipeline system in the air gap zone shall be included.

Guidance note:

Maximum wave load effects may not always be experienced during the passing of the design wave. The maximum wave loads may be due to waves of a particular length, period or steepness.

The initial response to impulsive wave slam or slap usually occurs before the exposed part of the submarine pipeline system is significantly immersed. Therefore, other fluid loading on the system need not normally be applied with the impulsive load. However, due to structural continuity of the riser, global wave loading on other parts of the system must be considered in addition to the direct wave loading.

Wave slam occurs when an approximately horizontal member is engulfed by a rising water surface as a wave passes. The highest slamming forces occur for members at mean water level and the slam force directions are close to the vertical.

Wave slap is associated with breaking waves and can affect members at any inclination, but in the plane perpendicular to the wave direction. The highest forces occur on members above mean water level.

Both slam and slap loads are applied impulsively (over a short instant of time) and the dynamic response of the submarine pipeline system shall be considered.

---e-n-d---of---G-u-i-d-a-n-c-e---n-o-t-e---

315 Parts of the submarine pipeline system, located above the normal wave impact zone, may be exposed to wave loading due to wave run-up. Loads due to this effect shall be considered.

316 The increased loads from marine growth shall be considered as follows:

- Increased drag/lift area due to the marine growth
- Increased pipe surface roughness and resulting increase in drag coefficient and reduced lift coefficient
- Any beneficial effect of the marine growth should be ignored in stability analyses

317 Tide loads shall be considered when the water depth is a significant parameter, e.g. for the establishment of wave actions, pipe lay operation particularly near shore approaches/landfalls, etc.

C 400 Ice loads

401 In areas where ice may develop or drift, the possibility of ice loads on the pipeline system shall be considered.

Guidance note:

Ice loads may be due to ice frozen on the pipeline system itself, or partly due to floating ice, or combination of these two.

---e-n-d---of---G-u-i-d-a-n-c-e---n-o-t-e---

402 The possibility of ice scouring and impacts from drifting ice shall be considered for shore approaches and areas where ice may interfere with the seabed and the submarine pipeline system.

403 Increased hydrodynamic loading due to presence of ice shall be considered.

404 In case of ice frozen to parts of the submarine pipeline system or vessels, (e.g. due to sea spray) the following forces shall be considered:

- weight of the ice
- impact forces due to thaw of the ice
- forces due to expansion of the ice
- increased wind, waves and current forces due to increased exposed area.

405 Forces from floating ice shall be calculated according to recognised theory. Due attention shall be paid to the mechanical properties of the ice, contact area, shape of structure, direction of ice movements, etc. The oscillating nature of the ice forces (built-up of lateral force and fracture of moving ice) shall be taken into account. When forces due to lateral ice motion will govern structural dimensions, model testing of the ice-structure interaction may be required.

C 500 Earthquake

501 Load imposed by earth quake, either directly or indirectly (e.g. due to failure of pipeline gravel supports), shall be classified as accidental or environmental loads, depending on the probability of earthquake occurrence in line with accidental loads in F.

Guidance note:

Special attention shall be given to ensure that appropriate loads from earth quakes are included in the design. This implies that e.g. 100-year, 1000-year and 10 000-year characteristic return period values needs to be evaluated. Note that implementation of load (effect) factors may vary from code to code and also depends on characteristic return period for the load.

---e-n-d---of---G-u-i-d-a-n-c-e---n-o-t-e---

C 600 Characteristic environmental load effects

601 The characteristic environmental load and the corresponding load effect depend on condition:

- weather restricted condition
- unrestricted condition (temporary condition or permanent condition).

Figure 1 outlines the procedure for assessing environmental loads. Operation limits (OP_{LIM}) is the minimum environmental limitation of the operations involved in pipe laying, and may be pipe load effects, pipe handling, anchor handling, HSE issues etc.

Guidance note:

Limiting pipe load effects are typically local buckling or fatigue.

---e-n-d---of---G-u-i-d-a-n-c-e---n-o-t-e---

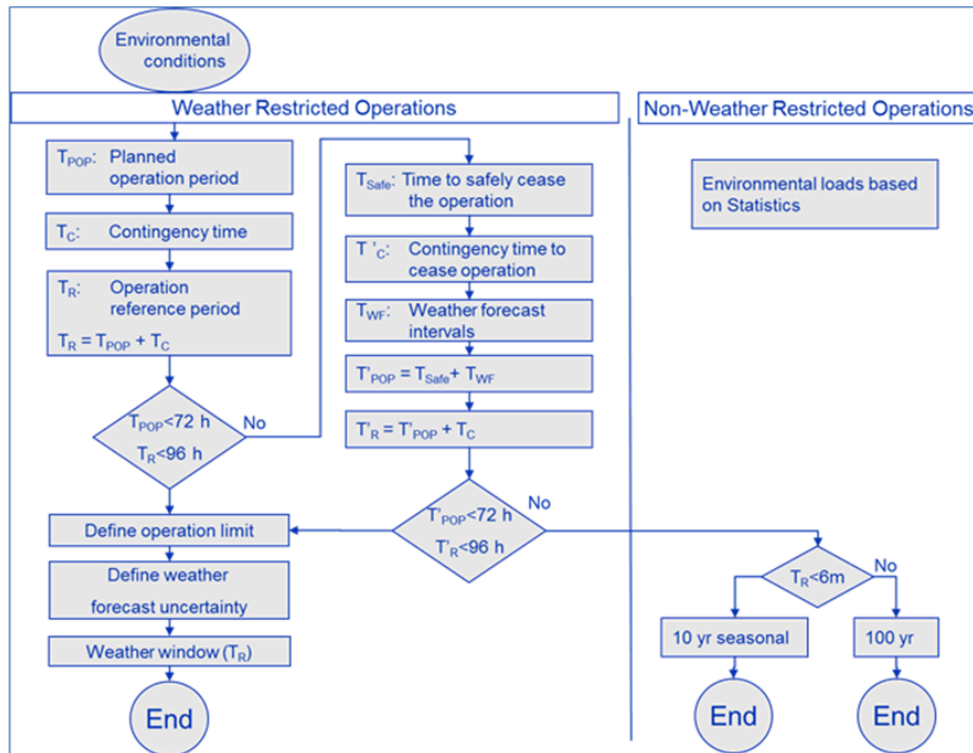

Figure 1
Determination of characteristic environmental load

602 Weather restricted operations may start-up based upon reliable weather forecast less than the operation limit. Uncertainty in the weather forecast for the operational period shall be considered.

Guidance note 1:

The operation limit may be defined by maximum allowed structural response (e.g. local buckling in the sag bend), anchor handling capability, safe working conditions on deck, assistance system or any limitations identified in HAZOP. In case operation limits are stricter for ceasing the operation than for normal laying this should be evaluated in detail.

---e-n-d---of---G-u-i-d-a-n-c-e---n-o-t-e---

Guidance note 2:

For weather restricted operations and example of how to account for the uncertainty in weather forecast reference is made to DNV-OS-H101.

---e-n-d---of---G-u-i-d-a-n-c-e---n-o-t-e---

603 Operations with a reference period (T_R) less than 96 hours and a planned operation period (T_{POP}) less than 72 hours can be defined as weather restricted. The operation reference period (T_R) is the planned operation period (T_{POP}) including contingency time, (T_C).

604 An operation can be defined as weather restricted operation even if the planned operation time exceeds 72 hours provided that the operation can be interrupted and put into a safe condition within the maximum allowable period for a weather restricted operation. The reference period for such operations is defined as the planned operation period for ceasing the operation, (T'_{POP}), including the contingency time for ceasing the operation (T'_C). The planned operation period for ceasing the operations is defined as the time to safely cease the operation (T_{Safe}) and the weather forecast intervals (T_{WF}).

605 An operation can be defined as a temporary condition if the duration is less than 6 months unless defined as weather restricted conditions. The environmental load effect for temporary conditions shall be taken as the 10-year return period for the actual season.

Guidance note:

Conditions exceeding 6 months but no longer than 12 months may occasionally be defined as temporary conditions.

---e-n-d---of---G-u-i-d-a-n-c-e---n-o-t-e---

606 Conditions not defined as weather restricted conditions or temporary conditions shall be defined as permanent conditions. The environmental load effect for permanent conditions shall be taken as the 100-year return period.

607 When considering the environmental design load the most unfavourable relevant combination, position and direction of simultaneously acting environmental loads shall be used in documenting the integrity of the submarine pipeline system. Functional loads (see B), interference loads (see E) and accidental loads (see F) shall be combined with the environmental loads as appropriate, see G103.

608 The characteristic environmental load effect for installation, L_E , is defined as the most probable largest load effect for a given seastate and appropriate current and wind conditions given by:

$$F(L_E) = 1 - \frac{1}{N} \quad (4.4)$$

where:

$F(L_E)$ is the cumulative distribution function of L_E , and N is the number of load effect cycles in a sea-state of a duration not less than 3 hours.

609 The most critical load effect combination for the relevant return period shall be used. When the correlations among the different environmental load components (i.e. wind, wave, current or ice) are unknown the characteristic combined environmental loads in Table 4-2 may be used.

Table 4-2 Combinations of characteristic environmental loads in terms of return period ¹⁾				
<i>Wind</i>	<i>Waves</i>	<i>Current</i>	<i>Ice</i>	<i>Earth quake</i>
Permanent condition				
100-year	100-year	10-year		
10-year	10-year	100-year		
10-year	10-year	10-year	100-year	
10-year	10-year	10-year		100-year ²⁾
Temporary condition				
10-year	10-year	1-year		
1-year	1-year	10-year		
1-year	1-year	1-year	10-year	
1-year	1-year	1-year		10-year ²⁾
1) This is in compliance with ISO 16708, but in conflict with ISO 13623 in case the design life is less than 33 years.				
2) Special attention shall be given to potential waves or current induces by earthquakes.				

D. Construction Loads

D 100 General

101 Loads which arise as a result of the construction and operation of the submarine pipeline system shall be classified into functional and environmental loads.

102 Construction loads include:

- stacking of pipes
- pipe transportation loads
- handling of pipe and pipe sections, e.g. lifting of pipe, pipe joints, pipe strings and pipe spools, and reeling of pipe strings
- static and dynamic installation loads
- pull-in at landfalls, tie-ins, trenching etc.
- pressure testing
- commissioning activities, e.g. increase in pressure differential due to vacuum drying
- dynamic loads from pre-commissioning activities, e.g. flooding and de-watering with pigs.

103 Inertia loads due to sudden water filling, excessive deformation in overbend and sagbend, and forces due to operation errors or failures in equipment that could cause or aggravate critical conditions shall be considered, see Sec.10 A300.

Guidance note:

The design criteria for such considerations will depend on the likelihood of the scenario. In case the likelihood is less than once in hundred years, it can be considered as an accidental limit state and be checked in accordance with Sec.5 D1000, else a normal ULS check apply.

---e-n-d---of---G-u-i-d-a-n-c-e---n-o-t-e---

104 For construction loads imposed by geometrical tolerances, extreme tolerances may be taken as mean \pm 3 standard deviations of the combined tolerances.

E. Interference Loads

E 100 General

101 Loads which are imposed on the pipeline system from 3rd party activities shall be classified as interference loads. Typical interference load include trawl interference, anchoring, vessel impacts and dropped objects.

102 The requirement for designing the submarine pipeline system for interference loads shall be determined based upon interference frequency studies and assessment of the potential damage. If the probability of occurrence is less than 10^{-2} within a year the load shall be classified as accidental load, see F.

103 The trawling loads can be divided in accordance with the three crossing phases:

- Trawl impact, i.e. the initial impact from the trawl board or beam which may cause local dents on the pipe or damage to the coating.
- Over-trawling, often referred to as pull-over, i.e. the second phase caused by the wire and trawl board or beam sliding over the pipe. This will usually give a more global response of the pipeline.
- Hooking, i.e. the trawl board is stuck under the pipe and in extreme cases, forces as large as the breaking strength of the trawl wire are applied to the pipeline.

Hooking has often a frequency less than 10^{-2} per year and then categorised as an accidental load.

104 Recommended practice for calculations of trawl interference loads is given in DNV-RP-F111.

105 The trawl impact energy shall be determined considering, as a minimum:

- the trawl gear mass and velocity
- the effective added mass and velocity.

The impact energy shall be used for testing of the pipeline coatings and possible denting of the pipeline wall thickness. In case piggy-back lines these shall also have adequate safety against trawl impacts.

106 Other 3rd party interference loads shall be calculated using recognised methods.

F. Accidental Loads

F 100 General

101 Loads which are imposed on a pipeline system under abnormal and unplanned conditions and with an probability of occurrence less than 10^{-2} within a year shall be classified as accidental loads.

102 Typical accidental loads can be caused by:

- extreme wave and current loads
- vessel impact or other drifting items (collision, grounding, sinking, iceberg)
- dropped objects
- infrequent internal over pressure (e.g. in case of malfunction of HIPPS)
- seabed movement and/or mud slides
- explosion
- fire and heat flux
- accidental water filling due to wet buckle
- operational malfunction
- dragging anchors.

103 Recommended practice for size and frequency of accidental loads is given in DNV-RP-F107.

G. Design Load Effects

G 100 General

101 A load effect is the resulting cross sectional loads arising as response to applied loads (e.g. weight, pressure, drag).

102 The magnitude of a time variant load effect to be used in a limit state criterion is defined by its probability of being exceeded, the characteristic load effect.

103 The characteristic load effects from the different load categories are combined by load effect factors to constitute the design load effect.

G 200 Characteristic load

201 The characteristic load effect is a quantified load effect to be used in the design load effect calculation.

The characteristic load for time invariant loads is the nominal (average) load. The characteristic load for time variant loads is given in C600.

202 The characteristic load effect is composed of contributions of functional, environmental and interference load effects.

203 For non-weather restricted operations, the characteristic load will be the most critical 100-year load effect

Guidance note:

The 100-year return period implies a probability of exceedance of 10^{-2} within a year.

---e-n-d---of---G-u-i-d-a-n-c-e---n-o-t-e---

204 The most critical 100-year load effect is normally governed by extreme functional, extreme environmental, extreme interference or accidental load effect. Unless special evaluation is carried out to identify the most critical 100-year load effect, the characteristic load effects in Table 4-3 shall be used.

205 In addition to the characteristic loads defined above, the fatigue load case shall also be checked, see Table 4-3.

Table 4-3 Characteristic loads					
<i>Extreme Load</i>	<i>Load effect factor combination¹⁾</i>	<i>Functional load</i>	<i>Environmental load</i>	<i>Interference load</i>	<i>Accidental load</i>
Functional load effect	a, b	100-year ²⁾	1-year	Associated	NA
Environmental load effect	a, b	Associated ³⁾	100-year ⁴⁾	Associated	NA
Interference load effect	b	Associated ³⁾	Associated	UB	NA
Fatigue load effect ⁵⁾	c	Associated	Associated	Associated	NA
Accidental load effect	d	Associated	Associated	Associated	BE

Characteristic load definition
 n-year: Most probable maximum in n years, UB: Upper Bound, BE: Best estimate

- 1) The referred load effect factor combinations are given in Table 4-4.
- 2) This will normally be equivalent to an internal pressure equal to the local incidental pressure combined with expected associated values of other functional loads.
- 3) This will normally be equivalent to an internal pressure and temperature not less than the operating pressure and the operating temperature profiles.
- 4) As defined in Table 4-2.
- 5) The fatigue load cases are;
 - a) cyclic functional loading (start-up and shut-down, pressure and temperature cycles shall be represented),
 - b) random environmental load (e.g. wave and current spectra, conservative pressure and temperature for the fatigue damage shall be used) and
 - c) repeated interference loading (conservative pressure and temperature for the fatigue damage shall be used)

G 300 Design load effect

301 Each limit state, see Sec.5 D, shall be checked for the design load effect.

302 The design load effect can generally be expressed in the following format:

$$L_{Sd} = L_F \cdot \gamma_F \cdot \gamma_c + L_E \cdot \gamma_E + L_I \cdot \gamma_F \cdot \gamma_c + L_A \cdot \gamma_A \cdot \gamma_c \quad (4.5)$$

In specific forms, this corresponds to:

$$M_{Sd} = M_F \cdot \gamma_F \cdot \gamma_c + M_E \cdot \gamma_E + M_I \cdot \gamma_F \cdot \gamma_c + M_A \cdot \gamma_A \cdot \gamma_c \quad (4.6)$$

$$\varepsilon_{Sd} = \varepsilon_F \cdot \gamma_F \cdot \gamma_c + \varepsilon_E \cdot \gamma_E + \varepsilon_I \cdot \gamma_F \cdot \gamma_c + \varepsilon_A \cdot \gamma_A \cdot \gamma_c \quad (4.7)$$

$$S_{Sd} = S_F \cdot \gamma_F \cdot \gamma_c + S_E \cdot \gamma_E + S_I \cdot \gamma_F \cdot \gamma_c + S_A \cdot \gamma_A \cdot \gamma_c \quad (4.8)$$

Guidance note:

The load combinations to the left are referred to explicitly in the limit state criteria, e.g. Eq. (5.19).

---e-n-d---of---G-u-i-d-a-n-c-e---n-o-t-e---

303 The design load effect shall be calculated for the characteristic load (see G200) for all relevant load effect combinations and corresponding load effect factors in Table 4-4.

Table 4-4 Load effect factor combinations

Limit State / Load combination	Load effect combination		Functional loads ¹⁾	Environmental load	Interference loads	Accidental loads
			γ_F	γ_E	γ_F	γ_A
ULS	a	System check ²⁾	1.2	0.7		
	b	Local check	1.1	1.3	1.1	
FLS	c		1.0	1.0	1.0	
ALS	d		1.0	1.0	1.0	1.0

1) If the functional load effect reduces the combined load effects, γ_F shall be taken as 1/1.1.
 2) This load effect factor combination shall only be checked when system effects are present, i.e. when the major part of the pipeline is exposed to the same functional load. This will typically only apply to pipeline installation.

Guidance note:

The partial safety factors in DNV-OS-F101 have been determined by structural reliability methods to a pre-defined failure probability. Structural reliability calculations differentiate between single joint failures (local checks) and series system failures (system effects).

These two kinds of scenarios are expressed as two different load effect combinations in DNV-OS-F101:

- a) shall only be considered for scenarios where system effects are present
- b) for local scenarios and shall always be considered.

When system effects are present, the pipeline will fail at its weakest point. Hence, the likely load shall be combined with the extreme low resistance. Applied to pipelines system effect can be expressed as the weakest link principle (where the chain gets weaker the longer the chain is). This is characterised by that the whole pipeline is exposed to the same load over time.

Applied to pipelines, system effects are present for:

- pressure containment
- collapse, in as installed configuration
- installation.

The first two are handled by the use of thickness t_1 . This is also why thickness t_2 and not t_1 is used for the burst capacity in the local buckling for pressurised pipes, since it is a local check.

Regarding installation, an extreme environmental load is not likely to occur when the weakest pipe section is at the most exposed location indicating that system effects not are present. However, combined with a more representative environmental load (in the extreme case, “flat sea”), the whole pipeline will undergo the same deformation “over time”, hence, having a system effect present.

In Table 4-4, load effect factor combination a has a load effect factor of 1.2 for the functional load to cover the system effect combined with a 0.7 load effect factor for the extreme environmental load giving a more “representative” environmental load, applicable for the above.

Another example of where system effects are present is for reeling where the whole pipe is exposed to the same deformation (neglecting the variation in drum diameter increase). For this application, a condition load factor of 0.82 applies, giving the total load effect factor of $1.2 \times 0.82 = 1.0$.

Hence, load combination b shall always be checked while load combination a normally is checked for installation only.

---e-n-d---of---G-u-i-d-a-n-c-e---n-o-t-e---

304 The condition load effect factor applies to the conditions in Table 4-5. Condition load effect factors are in addition to the load effect factors and are referred to explicitly in Eq. (4.5, 4.6 and 4.7).

Table 4-5 Condition load effect factors, γ_C	
Condition	γ_C
Pipeline resting on uneven seabed	1.07
Reeling on and J-tube pull-in	0.82
System pressure test	0.93
Otherwise	1.00

Guidance note:

“Uneven seabed” refers to pipeline resting on the seabed and not to installation on un-even seabed. Several condition factors may be required simultaneously, e.g. for pressure testing of pipelines on seabed, the resulting condition factor will be $1.07 \cdot 0.93 = 1.00$.

---e-n-d---of---G-u-i-d-a-n-c-e---n-o-t-e---

G 400 Load effect calculations

401 The load effect calculations shall be based on accepted principles of statics, dynamics, strength of materials and soil mechanics.

402 Industry recognised calculations tools, or tools documented to provide corresponding results, should be used for design and construction analyses of the submarine pipeline system.

403 Model tests may be used in combination with, or instead of, theoretical calculations. In cases where theoretical methods are inadequate, model or full-scale tests may be required.

404 The dynamic effect shall be taken into account when determining responses to dynamic loads.

405 The effect of statistical uncertainty due to the amount and accuracy of data shall be assessed and, if significant, shall be included in the evaluation of the characteristic load effect.

406 When non-linear material is required in the analyses the stress-strain curve shall be based on specified minimum values accounting for temperature derating (f_y and f_u) considered being engineering stress values, except for when the mean or upper bound values are explicitly required by the procedure (e.g. for fracture mechanics applications). The use of true versus engineering stress strain curve shall be consistent.

Guidance note:

The strain at f_u is normally considerably less than the fracture strain and is normally in the order of 6 to 10%. This should be determined from tests of similar material.

---e-n-d---of---G-u-i-d-a-n-c-e---n-o-t-e---

407 Load effect calculation should be performed applying nominal cross section values unless otherwise required by the code.

Guidance note:

Special attention shall be given to ensure that conservative load effect calculations are performed, implying that the applied cross section values are conservative.

---e-n-d---of---G-u-i-d-a-n-c-e---n-o-t-e---

408 The effective axial force that determines the global response of a pipeline is denoted S. Counting tensile force as positive:

$$S(p_i) = N - p_i \cdot A_i + p_e \cdot A_e = N - \frac{\pi}{4} \cdot (p_i \cdot (D - 2 \cdot t_2)^2 - p_e \cdot D^2) \quad (4.9)$$

409 Split up into functional, environmental and accidental effective force, the following applies:

$$S_F(p_i) = N_F - p_i \cdot A_i + p_e \cdot A_e = N_F - \frac{\pi}{4} \cdot (p_i \cdot (D - 2 \cdot t_2)^2 - p_e \cdot D^2) \quad (4.10)$$

$$S_E = N_E$$

$$S_A = N_A$$

410 In the as-laid condition, when the pipe temperature and internal pressure are the same as when the pipe was laid,

$$S = H \quad (4.11)$$

Where H is the effective (residual) lay tension. The effective residual lay tension may be determined by comparing the as-laid survey data to results from FE analysis.

411 Effective axial force of a totally restrained pipe in the linear elastic stress range is:

$$S = H - \Delta p_i \cdot A_i \cdot (1 - 2 \cdot \nu) - A_s \cdot E \cdot \alpha \cdot \Delta T \quad (4.12)$$

where:

H = Effective (residual) lay tension

Δp_i = Internal pressure difference relative to as laid

ΔT = Temperature difference relative to as laid.

SECTION 5 DESIGN – LIMIT STATE CRITERIA

A. General

A 100 Objective

101 This section provides limit state criteria and general requirements for the submarine pipeline systems.

A 200 Application

201 This standard includes no limitations on water depth. However, when this standard is applied in deep water where experience is limited, special consideration shall be given to:

- other failure mechanisms than those given in this section
- validity of parameter range (environmental/design/operational parameters)
- dynamic effects.

202 This standard does not specify any explicit limitations with respect to elastic displacements or vibrations, provided that the effects of large displacements and dynamic behaviour, including fatigue effect of vibrations, operational constraints and ratcheting, are taken into account in the strength analyses and found acceptable.

203 This standard does not specify any limitations on pipe geometries but some limit states were developed for a limited geometry and load range that is stated with the criterion. For geometries and loads outside these limits, criteria need to be developed in accordance with the safety philosophy in Sec.2.

204 The local buckling limit states, see D300 to D600, are only applicable to pipelines that are straight in stress-free condition and are not applicable to e.g. bends.

205 For parts of the submarine pipeline system which extend onshore complementary requirements are given in Appendix F.

206 For spiral welded pipes, the following additional limitations apply:

- when supplementary requirement F (fracture arrest properties) is specified, see Sec.7, the possibility for a running fracture to continue from a weld in one pipe joint to the weld of the next pipe joint shall be assessed
- external pressure resistance should be documented
- the design shall be based on the load controlled condition, see D600, unless the feasibility for use of displacement controlled condition can be documented.

Guidance note:

The limitations to fracture arrest and load controlled condition are due to limited experience with spiral welded pipes subjected to running fracture or large strains.

---e-n-d---of---G-u-i-d-a-n-c-e---n-o-t-e---

A 300 Systematic review

301 The overall requirement to systematic review in Sec.2 will for this section imply:

- A clear definition of code break between components and pipeline system
- Clear definition of the codes' pressure definitions correspondence
- A clear description of the overall system including interfaces and responsibilities, covering both temporary and permanent phases.
- An overall review of all potential failure modes shall be conducted
- The structural integrity and functionality of pipeline components shall comply with the safety requirements for the connected pipeline system, ref. Sec.2.
- Pre-commissioning activities

Guidance note:

The above will include a HAZID of the installation activity to identify potential impact on design such as selection of safety class during installation (ref. Sec.10 F800).

---e-n-d---of---G-u-i-d-a-n-c-e---n-o-t-e---

B. System Design Requirements

B 100 Submarine pipeline system layout

101 Pipelines, risers and J-tubes should be routed inside the structure to avoid vessel impact, and shall be

protected against impact loads from vessels and other mechanical interaction. Risers and J-tubes should not be located inside the loading zones of platforms.

102 The routing of risers and J-tubes shall be based on the following considerations:

- platform configuration and topsides layout
- space requirements
- movements of the riser or J-tube
- cable/pipeline approach
- riser or J-tube protection
- in-service inspection and maintenance
- installation considerations.

103 Crossing between pipelines and pipelines or cables should be kept separated by a minimum vertical distance of 0.3 m. Potential electrical interference and associated consequences between pipelines and cables shall be considered.

104 The submarine pipeline system shall be protected against unacceptable damage caused by e.g. dropped objects, fishing gear, ships, anchoring etc. Protection may be achieved by one or a combination of the following means:

- concrete coating
- burial
- cover (e.g. sand, gravel, mattress)
- other mechanical protection.

105 Relative settlement between the protective structure and the submarine pipeline system shall be properly assessed in the design of protective structures, and shall cover the full design life of the submarine pipeline system. Adequate clearance between the pipeline components and the members of the protective structure shall be provided to avoid fouling.

106 For structural items, doubler plates and rings welded directly to pressure containing parts, the following apply:

- Design shall be performed for all relevant failure modes, e.g. yielding, fatigue and fracture.
- For duplex stainless steels and 13Cr martensitic stainless steels a stress analysis shall be performed in each case to determine that local stresses will not initiate HISC. Recommended practice for design of duplex stainless steels is given in DNV-RP-F112.
- Welding directly to the pressure containing parts shall be performed in accordance with qualified welding procedures according to Appendix C.
- NDT shall be performed to ensure structural integrity of the pressure containing parts.
- The toe-to-toe distance from other welds shall be minimum $2 \cdot t$ or 50 mm, whichever is larger.

107 For doubler plates or rings the following apply:

- Design shall be performed for all relevant failure modes.
- Doubler plates should be circular.
- Welds shall be performed in accordance with qualified welding procedures.
- Doubler rings shall be made as fully encircling sleeves with the longitudinal welds made with backing strips, and avoiding penetration into the main pipe material.
- Other welds shall be continuous, and made in a manner minimising the risk of root cracking and lamellar tearing.

108 Girth welds should not be covered under doubler rings, clamps, or other items.

109 Riser and J-tube supports shall be designed to ensure a smooth transition of forces between riser/J-tube and support.

110 For requirements to transitions, see F112 through F115.

111 For piggable components the internal diameter of the component shall meet the requirements imposed by the pig-train.

Guidance note:

It is recommended that bends radius are designed with a radius not less than $5 \times$ nominal internal pipe diameter.

3D bends may be acceptable if PIG is designed for it, typically taking into account:

- Length of the pig;
- Pig-body diameter;
- Position of the seal- and guide-discs;
- Material and size of the discs;
- Position of the gauge-plate.

In addition, a trial fit to be performed.

---e-n-d---of---G-u-i-d-a-n-c-e---n-o-t-e---

B 200 Pressure test philosophy and criteria

201 The pressure containment capacity of the pipeline system is ensured by:

- Design criteria and safety factors
- Pressure testing all pressure containing parts by
 - Strength pressure test; Mill pressure test for pipe joints (Sec.7 E100) and hydrostatic test for components (Sec.8 G100), and
 - Gross error leak test; System pressure test (B203 and Sec.10 I300) and hydrostatic test for pipeline assemblies (Sec.7 E100)

Unless waived by B204 or Sec.7 E107.

Guidance note:

The purposes of the mill test are:

- to constitute a pressure containment proof test
- to ensure that all pipe sections have a minimum yield stress.

Therefore, the mill test pressure is defined in terms of stress utilisation, see Sec.7 E100, rather than in terms of design pressure. “in terms of stress utilisation” implies that the same structural utilisation will be achieved independent on temperature de-rating or corrosion allowance used in the design.

The purpose of the system pressure test is to prove the pressure containment of the submarine pipeline system, i.e. it constitutes a leakage test after completed construction disclosing gross errors.

The strength test shall reflect the highest utilisation the part will be exposed to during its entire life with probability less of being exceeded within a year less than 10^{-2} . The system pressure test differential pressure shall be α_{spt} higher than the 100-year pressure difference.

In case mill test or system test not meets the corresponding requirements in terms of pressure level this will result in limitations of the incidental pressure as per Eq. 5.6

---e-n-d---of---G-u-i-d-a-n-c-e---n-o-t-e---

202 The pipeline system shall be system pressure tested after installation in accordance with Sec.10 I300 unless this is waived by agreement in accordance with 203 below. The local test pressure (p_{lt}) during the system pressure test shall fulfil the following requirement for the safety class during normal operation:

$$p_{lt} \geq \alpha_{spt} p_{li} \tag{5.1}$$

α_{spt} see Table 5-9.

Guidance note:

With an incidental pressure of 10% above design pressure, the above gives a system test pressure of approximately 1.15 times the local design pressure (for safety class medium and high) at the highest point (given that the test medium density is higher than the density of the operational content of the pipeline system part tested), see Figure 1.

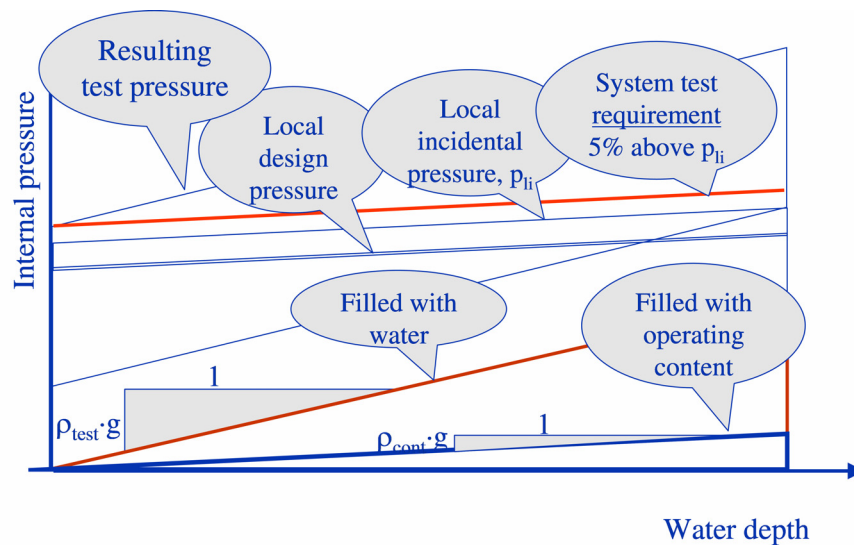

Figure 1
Illustration of local pressures and requirements to system pressure test

---e-n-d---of---G-u-i-d-a-n-c-e---n-o-t-e---

203 Alternative means to prove the same level of safety as with the system pressure test is allowed by agreement given that the mill pressure test requirement of Sec.7 E100 has been met and not waived in accordance with Sec.7 E107.

The industries knowledge and track record to date implies the limitations in Table 5-1 for waiving the system pressure test.

Table 5-1 Requirements to waive system pressure test	
<i>Requirement</i>	
Other aspects with respect to system pressure test than pressure containment integrity such as cleaning, contractual, shall be agreed.	
An inspection and test regime for the entire submarine pipeline system shall be established and demonstrated to provide the same level of safety as the system pressure test with respect to detectable defect sizes etc.; Records shall show that the specified requirements have consistently been obtained during manufacture, fabrication and installation.	<p>Guidance note: The requirement implies that a reporting limit lower than the acceptance criteria shall be used. This enables tracking of tendencies such that it can be documented that the criteria has been consistently met. It will also indicate systematic errors</p> <p style="text-align: center;">---e-n-d---of---G-u-i-d-a-n-c-e---n-o-t-e---</p>
Less than 75% of the pressure containment design resistance shall be utilised	<p>Guidance note: The requirement implies that external pressure governs the wall thickness design. For deep water pipelines, the benefit of a system pressure test is limited; hence this criterion. The limitation implies that the wall thickness shall be at least 33% larger than required by the pressure containment criterion.</p> <p style="text-align: center;">---e-n-d---of---G-u-i-d-a-n-c-e---n-o-t-e---</p>
The linepipe shall be seamless or produced by the SAW method. Repairs by other methods are allowed by agreement.	<p>Guidance note: Other welding methods have to date not proved similar degree of quality as SAW. SAW is not required for the girth welds</p> <p style="text-align: center;">---e-n-d---of---G-u-i-d-a-n-c-e---n-o-t-e---</p>
All components and risers shall be hydrostatically pressure tested during manufacture.	<p>Guidance note: Components include flanges, valves, fittings, mechanical connectors, induction bends, couplings and repair clamps, pig traps etc.</p> <p style="text-align: center;">---e-n-d---of---G-u-i-d-a-n-c-e---n-o-t-e---</p>
Automated Ultrasonic Testing (AUT) shall be performed after installation welding. Alternative NDT methods proven to give the same detectability and sizing accuracy may be allowed by agreement.	<p>Guidance note: AUT is normally required in order to ensure that no critical defects exist. The acceptance criterion is often based on an ECA linking the fracture toughness, defects and loads. A reporting limit less than this acceptance criteria is required in order to ensure that there is no systematic error on the welding and to prove that the criteria are systematically met.</p> <p style="text-align: center;">---e-n-d---of---G-u-i-d-a-n-c-e---n-o-t-e---</p>
The pipeline shall not be exposed to accumulated nominal plastic strains exceeding 2% after AUT.	
Installation and intervention work shall be unlikely to have caused damage to the submarine pipeline system.	<p>Guidance note: Special attention shall here be given to ploughing, other trenching methods or third party damages e.g. anchor chains of wires.</p> <p style="text-align: center;">---e-n-d---of---G-u-i-d-a-n-c-e---n-o-t-e---</p>

204 During system pressure test, all limit states for safety class low shall be satisfied (see D).

B 300 Monitoring/inspection during operation

301 The parameter safety envelope established in the conceptual phase, see Sec.3 C100 and D200, shall be extended/modified in the design phase by the parameters which could violate limit states of a pipeline system. These shall be monitored, inspected and evaluated with a frequency which enables remedial actions to be carried out before the system is damaged, see Sec.11.

Guidance note:

As a minimum the monitoring/inspection frequency should be such that the pipeline system will not be endangered due to any realistic degradation/deterioration that may occur between two consecutive inspection intervals.

---e-n-d---of---G-u-i-d-a-n-c-e---n-o-t-e---

302 Special focus shall be on monitoring and inspection strategies for “live pipeline systems” i.e. pipeline systems that are designed to change the configuration during its design life.

Guidance note:

Example of such systems may be pipelines that are designed to experience global buckling or possible free-span developments or potential pipeline walking.

---e-n-d---of---G-u-i-d-a-n-c-e---n-o-t-e---

303 Instrumentation of the pipeline system may be required when visual inspection or simple measurements are not considered practical or reliable, and available design methods and previous experience are not sufficient for a reliable prediction of the performance of the system.

304 Operating requirements affecting safety and reliability of the pipeline system shall be identified during the design phase, and shall be documented in the DFI Resumé and reflected in the PIM system.

C. Design Format

C 100 General

101 The design format in this standard is based on a Load and Resistance Factor Design (LRFD) format.

102 The fundamental principle of the LRFD format is to verify that design load effects, L_{Sd} , do not exceed design resistances, R_{Rd} , for any of the considered failure modes in any load scenario:

$$f\left(\left(\frac{L_{Sd}}{R_{Rd}}\right)_i\right) \leq 1 \tag{5.2}$$

Where the fractions i denotes the different loading types that enters the limit state.

103 A design load effect is obtained by combining the characteristic load effects from the different load categories and certain load effect factors, see Sec.4 G.

104 A design resistance is obtained by dividing the characteristic resistance by resistance factors that depends on the safety class, reflecting the consequences of failures, see 200.

C 200 Design resistance

201 The design resistance, R_{Rd} , can generally be expressed in the following format:

$$R_{Rd} = \frac{R_c(f_c, t_c, f_0)}{\gamma_m \cdot \gamma_{SC}} \tag{5.3}$$

where

- R_c is the characteristic resistance
- f_c is the characteristic material strength, see Eq. 5.4 and Eq.5.5
- t_c is the characteristic thickness, see Table 5-6 and Table 5-7
- f_0 is the out of roundness of the pipe, prior to loading
- γ_m, γ_{SC} are the partial resistance factors, see Table 5-2 and Table 5-3

202 Ovality of the pipeline is defined in Eq. 5.14. This will affect the structural capacity of the pipeline and shall be taken as the maximum ovality prior to loading. Advantage of an ovality less than 0.5% is not allowed. Ovality in excess of 3% shall be assessed in line with D900.

203 The material resistance factor, γ_m , is dependent on the limit state category and is defined in Table 5-2.

Limit state category ¹⁾	SLS/ULS/ALS	FLS
γ_m	1.15	1.00
1) The limit states (SLS, ULS, ALS and FLS) are defined in D.		

204 Based on potential failure consequences the pipeline shall be classified into a safety class see Sec.2 C400. This will be reflected in the safety level by the Safety Class resistance factor γ_{SC} given in Table 5-3. A corresponding safety class dependent strain resistance factor is defined for the displacement controlled limit state, see D608, 609 and Table 5-10.

The safety class may vary for different phases and different locations.

Safety class	γ_{SC}		
	Low	Medium	High
Pressure containment ¹⁾	1.046 ^{2),3)}	1.138	1.308 ⁴⁾
Other	1.04	1.14	1.26

1) The number of significant digits is given in order to comply with the ISO usage factors.
 2) Safety class low will be governed by the system pressure test which is required to be 3% above the incidental pressure. Hence, for operation in safety class low, the resistance factor will effectively be minimum 3% higher.
 3) For system pressure test, α_U shall be equal to 1.00, which gives an allowable hoop stress of 96% of SMYS both for materials fulfilling supplementary requirement U and those not.
 4) For parts of pipelines in location class 1, resistance safety class medium may be applied (1.138).

205 Possible beneficial strengthening effect of weight coating on a steel pipe shall not be taken into account in the characteristic resistance, unless the strengthening effect is documented. Coating which adds significant bending stiffness to the pipe may increase the stresses/strains in the pipe at any discontinuity in the coating (e.g. at field joints). When appropriate, this effect shall be taken into account.

206 Possible beneficial strengthening effect of cladding or liner on a steel pipe shall not be taken into account in the characteristic resistance, unless the strengthening effect is documented.

C 300 Characteristic material properties

301 Characteristic material properties shall be used in the resistance calculations. The yield stress and tensile strength in the limit state formulations shall be based on the engineering stress-strain curve.

302 The characteristic material strength f_y and f_u , values to be used in the limit state criteria are:

$$f_y = (SMYS - f_{y,temp}) \cdot \alpha_U \tag{5.4}$$

$$f_u = (SMTS - f_{u,temp}) \cdot \alpha_U \tag{5.5}$$

Where:

$f_{y,temp}$ and $f_{u,temp}$ are the de-rating values due to the temperature of the yield stress and the tensile strength respectively, see 304.

α_U is the material strength factor, see Table 5-4.

303 The different mechanical properties refer to room temperature unless otherwise stated.

304 The material properties shall be selected with due regard to material type and potential temperature and/or ageing effects and shall include:

- yield stress
- tensile strength
- Young's modulus
- temperature expansion coefficient.

For C-Mn steel and 13Cr this shall be considered for temperatures above 50°C, and for 22Cr and 25Cr for temperatures above 20°C.

Guidance note 1:

Field joint coating application during installation may also impose temperatures in excess of the above and shall be considered.

---e-n-d---of---G-u-i-d-a-n-c-e---n-o-t-e---

Guidance note 2:

If no other information of de-rating effects on the yield stress exist the recommendations for C-Mn steel, 22Cr and 25Cr Figure 2 below may be used. For 13Cr testing is normally required.

---e-n-d---of---G-u-i-d-a-n-c-e---n-o-t-e---

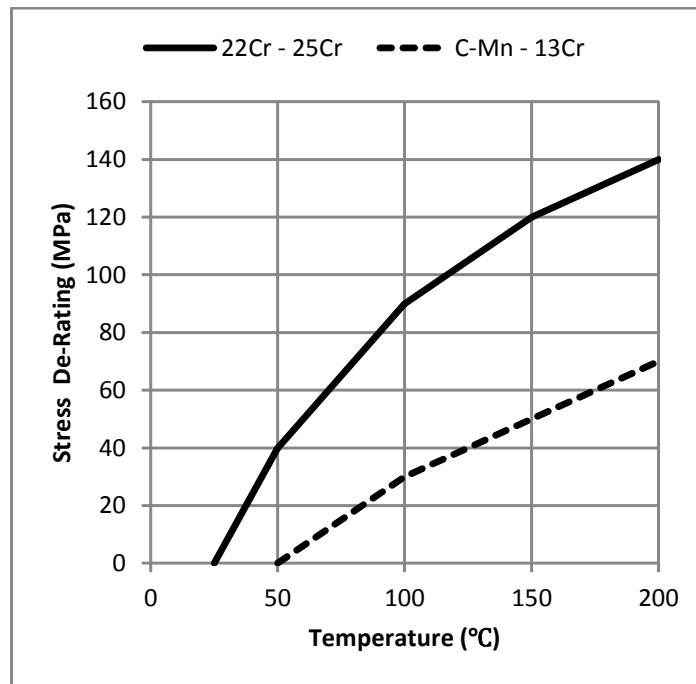

Figure 2
 Proposed de-rating values for yield stress of C-Mn, 13Cr, 22Cr and 25Cr

Guidance note:

If no other information on de-rating effect of the ultimate stress exists, the de-rating of the yield stress can be conservatively applied.

---e-n-d---of---G-u-i-d-a-n-c-e---n-o-t-e---

305 Any difference in the de-rating effect of temperature for tension and compression shall be accounted for.

Guidance note:

Difference in de-rating effect for tension and compression has been experienced on 13Cr steel material.

---e-n-d---of---G-u-i-d-a-n-c-e---n-o-t-e---

306 The material strength factor, α_U , depend on Supplementary requirement U as shown in Table 5-4.

Factor	Normally	Supplementary requirement U
α_U	0.96	1.00

Note: For system pressure test, α_U shall be equal to 1.00, which gives an allowable hoop stress of 96% of SMYS both for materials fulfilling supplementary requirement U and those not. This is equivalent to the mill test utilisation.

Guidance note:

The application of supplementary requirement U requires documentation after the manufacture and shall be used with care. Based on production data, it may be used for future upgrade of the pipeline

---e-n-d---of---G-u-i-d-a-n-c-e---n-o-t-e---

307 For manufacturing processes which introduce cold deformations giving different strength in tension and compression, a fabrication factor, α_{fab} , shall be determined. If no other information exists, maximum fabrication factors for pipes manufactured by specific processes are given in Table 5-5.

The fabrication factor may be increased through heat treatment or external cold sizing (compression), if documented.

Pipe	Seamless	UO & TRB & ERW	UOE
α_{fab}	1.00	0.93	0.85

308 For material susceptible to HISC, see D900 and Sec.6 B300.

C 400 Characteristic wall thickness

401 Two different characterisations of the wall thickness are used; t_1 and t_2 and are referred to explicitly in the design criteria. Thickness t_1 is used where failure is likely to occur in connection with a low capacity (i.e. system effects are present) while thickness t_2 is used where failure is likely to occur in connection with an extreme load effect at a location with average thickness. These are defined in Table 5-6.

	Prior to operation ¹⁾	Operation ²⁾
t_1	$t-t_{fab}$	$t-t_{fab}-t_{corr}$
t_2	t	$t-t_{corr}$

1) Is intended when there is negligible corrosion (mill pressure test, construction (installation) and system pressure test condition). If corrosion exist, this shall be subtracted similar to as for operation.
 2) Is intended when there is corrosion.

402 If relevant, erosion allowance shall be compensated for in the similar way as the corrosion allowance. Minimum wall thickness independent on limit state requirements are given in Table 5-7.

Safety Class	Location class	Minimum thickness
High	2	12 mm unless equivalent protection against accidental loads, other external loads and excessive corrosion is provided by other means. For diameters less than 219 mm (8") minimum wall thickness can be less but shall be determined including the above considerations.

The minimum wall thickness requirement is based on failure statistics, which clearly indicate that impact loads and corrosion are the most likely causes of failure and have the decisive effect on thickness design (not D/t_2).

403 Wall thickness for on bottom stability calculations is given in E502.

C 500 Stress and strain calculations

501 Local stress and strain concentrations may be caused by:

- Weld geometry (e.g. high/low)
- Weld material properties
- Welded attachments (e.g. anode pads)

502 The strain concentration shall account for the non-linear stress-strain relationship for the relevant load level considering:

- reduction of yield stress in field joints due to high temperature imposed by field joint coating application during installation
- undermatch/overmatch of actual weld metal yield stress, relative to actual pipe material yield stress.

503 Local stress and strain concentration factors (SCF/SNCF) shall be included in fatigue and fracture assessments in line with the limit state.

Guidance note:

Local stress concentrations (that may be caused by welded attachments, the weld itself, or very local discontinuities) will affect the pipe only locally and are typically accounted for in fatigue and fracture evaluations. Global stress concentrations (such as stress amplifications in field joints due to concrete coating, which typically extend one diameter) will affect the pipe globally, and shall be accounted for in the local buckling evaluations as well as fatigue and fracture evaluations.

---e-n-d---of---G-u-i-d-a-n-c-e---n-o-t-e---

Different approaches for calculation of the SNCF for fracture assessment are specified in Appendix A.

504 Global stress and strain concentrations may be caused by:

- variations in actual material yield stress and strain hardenability between pipe joints and in the weld metal due to scatter in material properties
- variations in cross sectional area (actual diameter or wall thickness) between pipe joints
- stiffening effects of coating and variations in coating thickness

505 Plastic strain shall be calculated from the point where the material stress-strain curve deviates from a linear relationship, see Figure 3.

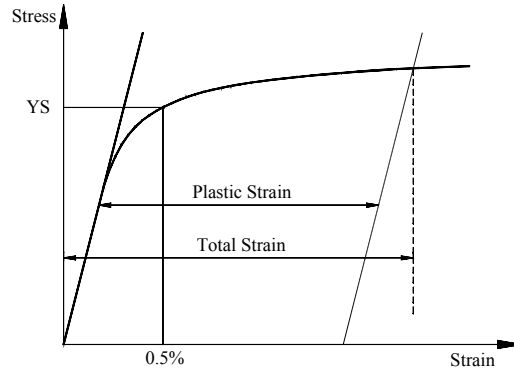

Figure 3
Reference for plastic strain calculation

Guidance note:

The yield stress is defined as the stress at which the total strain is 0.5%. As an example for a 415 grade C-Mn steel, a unidirectional strain of 0.5% corresponds to an elastic strain of approximately 0.2% and a plastic strain of 0.3%.

---e-n-d---of---G-u-i-d-a-n-c-e---n-o-t-e---

D. Limit States

D 100 General

101 All relevant limit states (failure modes) shall be considered in design for all relevant phases and scenarios listed in Sec.4.

Guidance note:

Limit state design implies that the pipeline is checked for all relevant failure modes. The failure modes vary in criticality and are split into the following limit state categories:

- Serviceability Limit State Category
- Ultimate Limit State Category
 - Fatigue Limit States
 - Accidental Limit State

Fatigue and accidental limit states are sub-categories of Ultimate Limit States accounting for accumulated cyclic load effects and accidental (in-frequent) loads respectively.

Pipeline limit state checks are typically split into different scenarios. A scenario is not identical with a limit state, and may include different limit states. A typical link between scenarios and limit states is given in Table 5-8.

Scenario	Ultimate Limit States						Serviceability Limit States			
	Bursting	Fatigue	Fracture	Collapse	Propagating buckling	Combined loading	Dent	Ovalisation	Ratcheting	Displacement
Wall thickness design	X			X	X					
Installation		X	X	X	X	X		X		X
Riser	X	X	X	X	X	X		X		X
Free-span	(X)	X	X			X				
Trawling/3rd party	(X)	X				X	X			
On bottom stability	(X)	(X)	(X)			(X)	(X)	(X)		X ¹
Pipeline Walking		X				X				
Global Buckling	(X)	X	X			X			X	

1) Typically applied as a simplified way to avoid checking each relevant limit state

---e-n-d---of---G-u-i-d-a-n-c-e---n-o-t-e---

102 In case no specific design criterion is given for a specific limit state this shall be developed in compliance with the safety philosophy in Sec.2.

D 200 Pressure containment (bursting)

201 The pressure containment shall fulfil the following criteria:

$$p_{li} - p_e \leq \text{Min} \left(\frac{p_b(t_1)}{\gamma_m \cdot \gamma_{SC}}; \frac{p_{lt}}{\alpha_{spt}} - p_e; \frac{p_h}{\alpha_{mpt} \cdot \alpha_U} \right) \quad (5.6)$$

$$p_{lt} - p_e \leq \text{Min} \left(\frac{p_b(t_1)}{\gamma_m \cdot \gamma_{SC}}; p_h \right) \quad (5.7)$$

Unless the mill test has been waived or limited in accordance with Sec.7 E100 or the system test has been waived in accordance with B204. α_{mpt} and α_{spt} are given in Table 5-9.

	γ_{SC}		
<i>Safety class</i>	<i>Low</i>	<i>Medium</i>	<i>High</i>
α_{mpt} ¹	1,000	1,088	1,251
α_{spt}	1,03	1,05	1,05

1) This factor is given by:

$$\frac{\gamma_m \cdot \gamma_{SC} \cdot 0.96}{2/\sqrt{3}}$$

202 The pressure containment resistance $p_b(t)$ is given by:

$$p_b(t) = \frac{2 \cdot t}{D - t} \cdot f_{cb} \cdot \frac{2}{\sqrt{3}} \quad (5.8)$$

where

$$f_{cb} = \text{Min} \left[f_y; \frac{f_u}{1.15} \right] \quad (5.9)$$

Guidance note:

In the above formulae, t shall be replaced by t_1 when used in Eq 5.7 and t_2 when used in Eq. 5.19.

---e-n-d---of---G-u-i-d-a-n-c-e---n-o-t-e---

203 Reduction in pressure containment resistance due to true compressive forces (load controlled), N, shall be considered. Recommended practice for reduction in pressure containment capacity due to compressive axial stresses is given in DNV-RP-F101.

D 300 Local buckling - general

301 Local buckling (pipe wall buckling) implies gross deformation of the cross section. The following criteria shall be fulfilled:

- system collapse (external over pressure only)
- propagation buckling (external over pressure only)
- combined loading criteria, i.e. interaction between external or internal pressure, axial force and bending moment.

These will be given in the following sub-sections.

302 Large accumulated plastic strain may aggravate local buckling and shall be considered.

D 400 Local Buckling – external over pressure only (system collapse)

401 The external pressure at any point along the pipeline shall fulfil the following criterion (system collapse check):

$$p_e - p_{\min} \leq \frac{p_c(t_1)}{\gamma_m \cdot \gamma_{SC}} \quad (5.10)$$

where

p_{min} is the minimum internal pressure that can be sustained. This is normally taken as zero for as-laid pipeline.

Guidance note:

The system collapse will occur at the weakest point in the pipeline. This will normally be represented by f_y and the minimum wall thickness, t_1 .

A seamless produced linepipe's weakest section may not be well represented by the minimum wall thickness since it is not likely to be present around the whole circumference. A larger thickness, between t_1 and t_2 , may be used for such pipes if this can be documented representing the lowest collapse capacity of the pipeline.

---e-n-d---of---G-u-i-d-a-n-c-e---n-o-t-e---

402 The characteristic resistance for external pressure (p_c) (collapse) shall be calculated as:

$$(p_c(t) - p_{el}(t)) \cdot (p_c(t)^2 - p_p(t)^2) = p_c(t) \cdot p_{el}(t) \cdot p_p(t) \cdot f_o \cdot \frac{D}{t} \quad (5.11)$$

where:

$$p_{el}(t) = \frac{2 \cdot E \cdot \left(\frac{t}{D}\right)^3}{1 - \nu^2} \quad (5.12)$$

$$p_p(t) = f_y \cdot \alpha_{fab} \cdot \frac{2 \cdot t}{D} \quad (5.13)$$

$$f_o = \frac{D_{max} - D_{min}}{D} \quad (5.14)$$

not to be taken < 0.005 (0.5%)

α_{fab} is the fabrication factor, see Table 5-5.

Guidance note 1:

In the above formulas, t shall be replaced by t_1 or t_2 as given in the design criteria.

---e-n-d---of---G-u-i-d-a-n-c-e---n-o-t-e---

Guidance note 2:

Ovalisation caused during the construction phase shall be included in the total ovality to be used in design. Ovalisation due to external water pressure or bending moment shall not be included.

---e-n-d---of---G-u-i-d-a-n-c-e---n-o-t-e---

D 500 Propagation buckling

501 Propagation buckling cannot be initiated unless local buckling has occurred. In case the external pressure exceeds the criterion given below, buckle arrestors should be installed and spacing determined based on cost and spare pipe philosophy. The propagating buckle criterion reads:

$$p_e - p_{min} \leq \frac{p_{pr}}{\gamma_m \cdot \gamma_{SC}} \quad (5.15)$$

where

$$p_{pr} = 35 \cdot f_y \cdot \alpha_{fab} \left(\frac{t_2}{D}\right)^{2.5} \quad (5.16)$$

$$15 < D/t_2 < 45$$

α_{fab} is the fabrication factor, see Table 5-5

Guidance note 1:

Collapse pressure, p_c , is the pressure required to buckle a pipeline.

Initiation pressure, p_{init} , is the pressure required to start a propagating buckle from a given buckle. This pressure will depend on the size of the initial buckle.

Propagating pressure, p_{pr} , is the pressure required to continue a propagating buckle. A propagating buckle will stop when the pressure is less than the propagating pressure.

The relationship between the different pressures are: $p_c > p_{init} > p_{pr}$

---e-n-d---of---G-u-i-d-a-n-c-e---n-o-t-e---

Guidance note 2:

The safety class and amount of metal loss due to corrosion shall be determined based on the probability and possibility of experiencing a high external over pressure during operation. For liquid pipelines, safety class low and non-corroded cross section is normally used while other properties may be used for gas pipelines since they may experience a nearly zero internal pressure in the operational phase.

Note that the possibility of a propagating buckle shall not be combined with the likelihood of getting an initiating event in the shut-down time span, since a dent caused during the pressurised condition, may start propagating as the internal pressure is lost.

---e-n-d---of---G-u-i-d-a-n-c-e---n-o-t-e---

502 A buckle arrestor capacity depends on

- propagating buckle resistance of adjacent pipe
- propagating buckle resistance of an infinite buckle arrestor
- length of arrestor.

An integral buckle arrestor may be designed by:

$$p_e \leq \frac{p_x}{1.1 \cdot \gamma_m \cdot \gamma_{SC}} \quad (5.17)$$

where the crossover pressure p_x is

$$p_x = p_{pr} + (p_{pr,BA} - p_{pr}) \cdot \left[1 - EXP\left(-20 \frac{t_2 \cdot L_{BA}}{D^2}\right) \right] \quad (5.18)$$

$p_{pr,BA}$ is the propagating buckle capacity of an infinite arrestor. This is calculated by Eq. 5.16 with the buckle arrestor properties

L_{BA} buckle arrestor length

Guidance note:

The propagating buckle criterion, Eq. 5.15, corresponds to a nominal failure probability that is one order of magnitude higher than the target nominal failure probability. This is because it is dependent on an initiating even. However, for a buckle arrestor, it is recommended to have a larger confidence and a safety class higher than for the propagating pressure is recommended.

---e-n-d---of---G-u-i-d-a-n-c-e---n-o-t-e---

D 600 Local buckling - combined loading criteria

601 Differentiation is made between:

- Load Controlled condition (LC condition)
- Displacement Controlled condition (DC condition).

Different limit states apply to these two conditions.

602 A load-controlled condition is one in which the structural response is primarily governed by the imposed loads.

603 A displacement-controlled condition is one in which the structural response is primarily governed by imposed geometric displacements.

Guidance note:

A pipeline checked for displacement controlled criteria will typically have tensile strains in excess of 0.4%. Fracture assessment is required if tensile strains exceed 0.4%, see 900.

---e-n-d---of---G-u-i-d-a-n-c-e---n-o-t-e---

604 A load controlled design criterion can always be applied in place of a displacement controlled design criterion.

Guidance note 1:

An example of a purely displacement-controlled condition is a pipeline bent into conformity with a continuous curved structure, such as a J-tube. In that case, the curvature of the pipe axis is imposed but the circumferential bending that leads to ovalisation is determined by the interaction between the curvature of the axis and the internal forces induced by the curvature.

A less clear-cut example is a pipeline in contact with the rollers of a lay barge stinger. On a large scale, the configuration of the pipeline has to conform to the rollers, and in that sense is displacement controlled. On a local scale however, bending of the pipe between the rollers is determined by the interaction between weight and tension and is load-controlled. Contact with the rollers will further reduce the capacity. The stinger tip will, however, always be load controlled.

Another intermediate case is an expansion spool in contact with the seabed. Pipeline expansion induced by temperature and pressure imposes a displacement at the end of the spool. The structural response of the spool itself has little effect on the imposed expansion displacement, and the response is primarily displacement-controlled. However, the lateral resistance to movement of the spool across the seabed also plays a significant part and induces a degree of load control.

System effect has also a slightly different effect in local buckling – combined loading than for bursting and collapse. A uniform moment/curvature cannot be applied to the whole pipeline at once but will typically occur as a peak moment “moving” along the pipeline. This applies to sag bend, stinger and reeling. Local buckling – combined loading will then be governed by the maximum moment capacity variation along the pipe. This will occur a small distance (typically in the order of a diameter) into the weak part, when the peak moment moves from strong to weak section. For such applications, more detailed assessment can be based on a weak link evaluation, where this weak link is the extreme variation from one joint to another.

The answer to the question on if a condition is load controlled or displacement controlled is impossible since the questions in wrong, the question should be; how can one take partial benefit of that a condition is partially displacement controlled element? On a general basis this needs sensitivity analyses. A load controlled criterion can, however, always be applied

---e-n-d---of---G-u-i-d-a-n-c-e---n-o-t-e---

Guidance note 2:

If the design is based on extreme variation from one joint to the other, benefit may be taken from selection of matching, as closely as possible, wall thickness/diameter of the pipes and the actual yield stress on both sides of the weld.

---e-n-d---of---G-u-i-d-a-n-c-e---n-o-t-e---

Load controlled condition

605 Pipe members subjected to bending moment, effective axial force and internal overpressure shall be designed to satisfy the following criterion at all cross sections:

$$\left\{ \gamma_m \cdot \gamma_{SC} \cdot \frac{|M_{Sd}|}{\alpha_c \cdot M_p(t_2)} + \left\{ \frac{\gamma_m \cdot \gamma_{SC} \cdot S_{Sd}(p_i)}{\alpha_c \cdot S_p(t_2)} \right\}^2 \right\}^2 + \left(\alpha_p \cdot \frac{p_i - p_e}{\alpha_c \cdot p_b(t_2)} \right)^2 \leq 1 \quad (5.19)$$

Applies for

$$15 \leq D/t_2 \leq 45, P_1 > P_e, |S_{Sd}|/S_p < 0.4$$

where

- M_{Sd} is the design moment, see Eq. 4.6
- S_{Sd} is the design effective axial force, see Eq. 4.8
- p_i is the internal pressure, see Table 4-3
- p_e is the external pressure, see Sec.4 B200
- p_b is the burst pressure, Eq. 5.8
- S_p and M_p denote the plastic capacities for a pipe defined by:

$$S_p(t) = f_y \cdot \pi \cdot (D - t) \cdot t \quad (5.20)$$

$$M_p(t) = f_y \cdot (D - t)^2 \cdot t \quad (5.21)$$

$$\alpha_c = (1 - \beta) + \beta \cdot \frac{f_u}{f_y} \quad (5.22)$$

$$\alpha_p = \begin{cases} 1 - \beta & \frac{p_i - p_e}{p_b} < \frac{2}{3} \\ 1 - 3\beta \left(1 - \frac{p_i - p_e}{p_b} \right) & \frac{p_i - p_e}{p_b} \geq \frac{2}{3} \end{cases} \quad (5.23)$$

$$\beta = \frac{60 - D/t_2}{90} \quad (5.24)$$

α_c is a flow stress parameter and α_p account for effect of D/t₂ ratio.

Guidance note:

For applications outside the axial load limitations, reference is made to DNV-OS-F201.

The left hand side of the combined loading criterion is referred to as interaction ratio in order not to mix it with “unity check”. In a unity check, the loads are normally directly proportional to the utilisation while the axial load and internal pressure are squared in this criterion.

---e-n-d---of---G-u-i-d-a-n-c-e---n-o-t-e---

606 If the pipeline in addition to the axial load, pressure and moment also has a lateral point load, this should be included by a modification of the plastic moment capacity as follows:

$$M_{p, \text{point load}} = M_p \cdot \alpha_{pm} \quad (5.25)$$

where

α_{pm} = Plastic moment reduction factor accounting for point load

$$\alpha_{pm} = 1 - \frac{D/t_2}{130} \frac{R}{R_y} \quad (5.26)$$

R = Reaction force from point load

$$R_y = 3.9 \cdot f_y \cdot t_2^2 \quad (5.27)$$

607 Pipe members subjected to bending moment, effective axial force and external overpressure shall be designed to satisfy the following criterion at all cross sections:

$$\left\{ \gamma_m \cdot \gamma_{SC} \cdot \frac{|M_{Sd}|}{\alpha_c \cdot M_p(t_2)} + \left\{ \frac{\gamma_m \cdot \gamma_{SC} \cdot S_{Sd}}{\alpha_c \cdot S_p(t_2)} \right\}^2 \right\}^2 + \left(\gamma_m \cdot \gamma_{SC} \cdot \frac{P_e - P_{min}}{p_c(t_2)} \right)^2 \leq 1 \quad (5.28)$$

$$15 \leq D/t_2 \leq 45, \quad P_i < P_e, \quad |S_{Sd}|/S_p < 0.4$$

where

p_{min} is the minimum internal pressure that can be sustained. This is normally taken as zero for installation except for cases where the pipeline is installed water filled.

p_c is the characteristic collapse pressure, Eq. 5.10. This shall be based on thickness t_2 .

Guidance note:

For applications outside the axial load limitations, reference is made to DNV-OS-F201

---e-n-d---of---G-u-i-d-a-n-c-e---n-o-t-e---

Displacement controlled condition

608 Pipe members subjected to longitudinal compressive strain (bending moment and axial force) and internal over pressure shall be designed to satisfy the following criterion at all cross sections:

$$\varepsilon_{Sd} \leq \varepsilon_{Rd} = \frac{\varepsilon_c(t_2, P_{min} - p_e)}{\gamma_\varepsilon} \quad (5.29)$$

$$D/t_2 \leq 45, \quad p_i \geq p_e$$

where:

ε_{Sd} = Design compressive strain, Eq. (4.6)

$$\varepsilon_c(t, P_{min} - p_e) = 0.78 \cdot \left(\frac{t}{D} - 0.01 \right) \cdot \left(1 + 5.75 \cdot \frac{P_{min} - p_e}{p_b(t)} \right) \cdot \alpha_h^{-1.5} \cdot \alpha_{gw} \quad (5.30)$$

p_{min} = Minimum internal pressure that can be continuously sustained with the associated strain

γ_ε = Strain resistance factor, Table 5-10

$$\alpha_h = \left(\frac{R_{t0,5}}{R_m} \right)_{\max}, \quad \text{Table 7.5 and Table 7.11}$$

α_{gw} = See Sec.13.

609 Pipe members subjected to longitudinal compressive strain (bending moment and axial force) and

external over pressure shall be designed to satisfy the following criterion at all cross sections:

$$\left(\frac{\varepsilon_{sd}}{\varepsilon_c(t_2, 0)} \right)^{0.8} + \frac{p_e - p_{min}}{p_c(t_2)} \leq 1 \quad (5.31)$$

$D/t_2 < 45, p_{min} < p_e$

Guidance note 1:

For $D/t_2 < 23$, the utilisation may be increased provided that full scale testing, observation, or former experience indicate sufficient safety margin in compliance with this standard. Any increased utilisation shall be supported by analytical design methods.

---e-n-d---of---G-u-i-d-a-n-c-e---n-o-t-e---

Guidance note 2:

System effects are normally not present for local buckling considerations and, hence, t_2 should be used. However, for reeling, a large portion of the pipeline will be exposed to similar curvature and load combination “a” shall be used combined with the condition factor of 0.82, yielding unity, and the nominal thickness can be used also for this criteria. The thickness and yield stress variation along the pipe, in particular between two pipe joints should be evaluated in addition to this system effect.

---e-n-d---of---G-u-i-d-a-n-c-e---n-o-t-e---

Table 5-10 Resistance strain factors, γ_ε		
Safety class		
Low	Medium	High
2.0	2.5	3.3

610 A higher probability of failure corresponding to a serviceability limit state may be allowed during the installation phase provided that:

- aids to detect buckle are provided
- repair of potential damage is feasible and may be performed during laying
- buckle arrestors are installed if the external pressure exceeds the initiation propagating pressure.

Relevant resistance factors may then be calibrated according to the SLS requirements in Sec.2.

D 700 Global buckling

701 Global buckling implies buckling of the pipe as a bar in compression.

702 The effect of internal and external pressures should be taken into account using the concept of an effective axial force, see Sec.4 G400. The procedure is as for “ordinary” compression members in air.

703 Distinction shall be made between load-controlled and displacement-controlled global buckling.

Load controlled global buckling condition is characterised by that the applied load is independent on the deflection of the pipeline

Displacement controlled, or partially displacement controlled global buckling condition is characterised by that the major part of the applied load is dependent on the deflection of the pipeline. Expansion force due to pressure and temperature are examples of such.

704 Load-controlled global buckling may be designed in accordance with DNV-OS-C101 Design of Offshore Steel Structures, General (LRFD).

705 For displacement controlled global buckling, see E300.

D 800 Fatigue

801 The submarine pipeline system shall have adequate safety against fatigue failures within the design life of the system.

802 All stress fluctuations imposed on the pipeline system during the entire design life, including the construction phase, which have magnitude and corresponding number of cycles large enough to cause fatigue effects shall be taken into account when determining the long-term distribution of stress ranges. The fatigue check shall include both low-cycle fatigue and high-cycle fatigue. The requirements regarding accumulated plastic strain (D900) shall also be satisfied.

Guidance note:

Typical causes of stress fluctuations in a pipeline system are:

- direct wave action
- vibrations of the pipeline system, e.g. due to vortex shedding (current, waves, wind, towing) or fluid flow
- supporting structure movements, e.g. installation vessel
- fluctuations in operating pressure and temperature.

Locations to be checked are the girth welds, seam welds and construction details. Seam welds will be more vulnerable to fatigue for higher steel grades.

---e-n-d---of---G-u-i-d-a-n-c-e---n-o-t-e---

803 Special consideration shall be given to the fatigue assessment of construction details likely to cause stress concentrations, and to the possibility of having low-cycle high strain fatigue. The specific design criterion to be used depends upon the analysis method, which may be categorised into:

- methods based upon fracture mechanics (see 804)
- methods based upon fatigue tests (see 805).

804 Where appropriate, a calculation procedure based upon fracture mechanics may be used. The specific criterion to be used shall be determined on a case-by-case basis, and shall reflect the target safety levels in Sec.2 C500. For further guidance on fracture mechanics based fatigue analyses see Appendix A.

805 When using calculation methods based upon fatigue tests, the following shall be considered:

- determination of long-term distribution of stress range, see 807
- selection of appropriate S-N curve (characteristic resistance), see 808
- determination of stress concentration factor (SCF) not included in the S-N curve
- determination of accumulated damage, see 809.

806 As most of the loads which contribute to fatigue are of a random nature, statistical consideration is normally required in determining the long-term distribution of fatigue loading effects. Where appropriate, deterministic or spectral analysis may be used.

807 The characteristic resistance is normally given as S-N curves or ε -N curves, i.e. stress amplitudes (or strain amplitudes for the case of low-cycle fatigue), versus number of cycles to failure, N. The S-N curve shall be applicable for the material, construction detail, NDT acceptance criteria and state of stress considered, as well as to the surrounding environment. The S-N curve shall be based on the mean curve of log (N) with the subtraction of two standard deviations in log (N). If a fracture mechanics assessment (ECA) is performed according to requirements in D1100, the S-N curve shall be validated for the allowable defect sizes determined by the ECA or a fracture mechanics based fatigue assessment shall be performed as described in Appendix A.

808 In the general case where stress fluctuations occur with varying amplitude of random order, the linear damage hypothesis (Miner's rule) may be used. The application of Miner's rule implies that the long-term distribution of stress range is replaced by a stress histogram, consisting of a number of constant amplitude stress or strain range blocks, $(\sigma_r)_i$ or $(\varepsilon_r)_i$, and the corresponding number of repetitions, n_i . Thus, the fatigue criterion is given by:

$$D_{fat} \cdot DFF \leq 1.0 \quad (5.32)$$

$$D_{fat} = \sum_{i=1}^k \frac{n_i}{N_i} \quad (5.33)$$

Where:

- D_{fat} = Miner's sum
- k = number of stress blocks
- n_i = number of stress cycles in stress block i
- N_i = number of cycles to failure at constant stress range of magnitude $(\sigma_r)_i$ or strain range $(\varepsilon_r)_i$.
- DFF = Design Fatigue Factor, see Table 5-11

809 Allowable Design Fatigue Factors are given in Table 5-11.

Table 5-11 Allowable Design Fatigue Factor			
<i>Safety Class</i>	<i>Low</i>	<i>Medium</i>	<i>High</i>
DFF	3	6	10

810 Recommended practice for fatigue calculations/analysis caused by vortex induced vibrations or direct wave loading is given in DNV-RP-F105 and DNV-RP-F204.

Guidance note:

Note that DNV-RP-F105 assumes all fatigue damage may be caused by vortex induced vibrations. The allowable fatigue damage ratio shall be reduced in accordance with 811.

---e-n-d---of---G-u-i-d-a-n-c-e---n-o-t-e---

811 The split between the different phases of the design fatigue life as described in Table 5-11 shall be agreed in the initiation phase of the project and be based on the highest safety class during the lifetime.

Guidance note:

For a pipeline where e.g. 50% of the design lifetime can be utilized during the installation and which is classified as safety class medium (high) during the operational phase this will correspond to a damage ratio of 10% (5%) of the operational lifetime.

A common split between installation, as laid and operation is 10%, 10% and 80% but depend on the need for fatigue capacity in the different phases. For a pipeline resting on the seabed with limited need for fatigue resistance in the operation phase (i.e. no free spans or buried pipeline), the split between installation, as laid and operation could be 80%, 10% and 10%.

---e-n-d---of---G-u-i-d-a-n-c-e---n-o-t-e---

812 Recommend practice for fatigue strength analysis is given in DNV-RP-C203. Recommended practice for environmental conditions and loads is given in DNV-RP-C205.

D 900 Fracture, supplementary requirement P and F and HISC

901 Pipeline systems shall have adequate resistance against initiation of unstable fracture.

902 The safety against unstable fracture is considered satisfactory if the requirements in Table 5-12 are met.

Table 5-12 Requirements to unstable fracture¹⁾		
<i>Total nominal strain</i>	<i>Accumulated plastic strain</i>	
$\epsilon_{l,nom} \leq 0.4\%$		Materials, welding, workmanship and testing are in accordance with the requirements of this standard As an alternative girth welds allowable defect sizes may be assessed according to Appendix A.
$0.4\% < \epsilon_{l,nom}$		The integrity of the girth welds shall be assessed in accordance with Appendix A
$1.0\% < \epsilon_{l,nom}^{2)}$		Supplementary requirement (P) shall be applied
or	$2.0\% < \epsilon_p$	
1) The strain levels refers to after NDT.		
2) Total nominal strain in any direction from a single event.		

903 Pipeline systems transporting gas or mixed gas and liquids under high pressure shall have adequate resistance to running ductile fractures. This may be achieved by using:

- material with low transition temperature and adequate Charpy V-notch toughness
- adequate DWTT shear fracture area
- lowering the stress level
- use of mechanical crack arrestors
- by a combination of these methods.

Design solutions shall be validated by calculations based upon relevant experience and/or suitable tests. Requirements to fracture arrest properties need not be applied when the pipeline design tensile hoop stress is below 40% of f_y .

Guidance note:

CO₂ is normally in the liquid dense phase during normal operation of a pipeline. When decompressed, CO₂ will change phase from liquid to gas, and this decompression behaviour is significantly different compared to natural gas, and needs to be accounted for in running ductile fracture assessments for pipelines conveying CO₂.

---e-n-d---of---G-u-i-d-a-n-c-e---n-o-t-e---

904 Material meeting the supplementary requirement for fracture arrest properties (F) (Sec.7 I200) is considered to have adequate resistance to running ductile fracture for applications carrying essentially pure methane up to 80% usage factor, 15 MPa internal pressure and 30 mm wall thickness. For depths down to 10 metres and onshore, the required Charpy V-notch impact energy shall be specially considered.

905 For duplex stainless steels and 13Cr martensitic stainless steels or other materials susceptible to HISC local stresses shall be sufficient low to avoid initiation of HISC. Recommended practice for design of duplex stainless steels is given in DNV-RP-F112.

D 1000 Ultimate limit state – accidental loads

1001 The design against accidental loads may be performed by direct calculation of the effects imposed by the loads on the structure, or indirectly, by design of the structure as tolerable to accidents.

1002 The acceptance criterion for ALS relate to the overall allowable probability of severe consequences.

1003 Design with respect to accidental load must ensure that the overall nominal failure probability complies with the nominal failure probability target values in Sec.2. The overall nominal failure probability from accidental loads can be expressed as:

$$\sum_i P_{fi|Di} \cdot P_{Di} \leq P_{f,target} \quad (5.34)$$

where

- $P_{fi|Di}$ is the probability of failure for the damaging event i
- P_{Di} is the probability of the damaging event i within a year
- $P_{f,target}$ is the target probability of failure within a year, see Sec.2 C
- $P_{f,T}$ is the relevant target nominal failure probability according to Sec.2. The number of discretisation levels must be large enough to ensure that the resulting probability is evaluated with sufficient accuracy.

1004 The inherent uncertainty of the frequency and magnitude of the accidental loads, as well as the approximate nature of the methods for determination of accidental load effects, shall be recognised. Sound engineering judgement and pragmatic evaluations are hence required.

1005 If non-linear, dynamic finite element analysis is applied, it shall be ensured that system performance and local failure modes (e.g. strain rate, local buckling, joint overloading and joint fracture) are adequately accounted for by the models and procedures applied.

1006 A simplified design check with respect to accidental load may be performed as shown in Table 5-13 using appropriate partial safety factors. The adequacy of simplified design check must be assessed on the basis of the summation above in order to verify that the overall failure probability complies with the target values in Sec.2.

<i>Prob. of occurrence ¹⁾</i>	<i>Safety Class Low</i>	<i>Safety Class Medium</i>	<i>Safety Class High</i>
$> 10^{-2}$	Accidental loads may be regarded similar to environmental loads and may be evaluated similar to ULS design check		
$10^{-2} - 10^{-3}$	To be evaluated on a case by case basis		
$10^{-3} - 10^{-4}$	$\gamma_C = 1.0$	$\gamma_C = 1.0$	$\gamma_C = 1.0$
$10^{-4} - 10^{-5}$	Accidental loads or events may be disregarded		$\gamma_C = 0.9$
$10^{-5} - 10^{-6}$			$\gamma_C = 0.8$
$< 10^{-6}$			

1) When failure mode is bursting the probability of occurrence should be 1-2 order of magnitudes lower, ref Table 2-5.

Note to table; Standard industry practice assumes safety factors equal to 1.0 for an accidental event with a probability of occurrence less than 10^{-2} within a year and survival of the pipeline is merely related to a conservative definition of characteristic resistance. In this standard, accidental loads and events are introduced in a more general context with a link between probability of occurrence and actual failure consequence. For combined loading the simplified design check proposes a total factor in the range 1.1-1.2, which is consistent with standard industry practice interpreted as corresponding to safety class Medium for accidental loads with a probability of occurrence equal to 10^{-4} .

D 1100 Ovalisation

1101 The submarine pipeline system shall not be subject to excessive ovalisation. The residual flattening due to bending and point loads, together with the out-of-roundness tolerance from fabrication of the pipe, is not to exceed 3%, defined as:

$$f_0 = \frac{D_{max} - D_{min}}{D} \leq 0.03 \quad (5.35)$$

The requirement may be relaxed if:

- a corresponding reduction in moment resistance has been included
- geometrical restrictions are met, such as pigging requirements
- additional cyclic stresses caused by the ovalisation have been considered
- tolerances in the relevant repair system are met.

1102 Ovalisation shall be checked for point loads at any point along the submarine pipeline system. Such point loads may arise at free-span shoulders, artificial supports and support settlements.

D 1200 Accumulated deformation

1201 Accumulated plastic deformation of pipe caused by cyclic loads leading to increased diameter or ovality (ratcheting) shall be considered. If the ratcheting causes increased ovality, special consideration shall also be made of the effect on buckling resistance.

1202 Accumulated longitudinal displacement of the pipeline (pipeline walking) shall be considered. This may occur during start-up/shut-down for:

- pipeline shorter than two anchor lengths, or
- pipeline parts with virtual anchor, and
- pipeline laying on seabed slope, or
- pipeline connected to pulling force (e.g. connected to SCR).

D 1300 Dent

1301 The acceptance criterion for impact refer to an acceptable dent size. The maximum accepted ratio of permanent dent depth to the pipe diameter is given in the following criterion:

$$\frac{H_p}{D} \leq 0.05\eta \quad (5.36)$$

where:

H_p = permanent plastic dent depth

η = usage factor given in Table 5-14. Load effect factors equal to unity.

<i>Impact frequency (per year per km)</i>	<i>Usage factor η</i>
> 100	0
1-100	0.3
10^{-4} -1	0.7

1302 When allowing for permanent dents, additional failure modes such as fatigue and collapse shall be taken into account. Any beneficial effect of internal over-pressure, i.e. “pop-out” should not be included. The beneficial effects of protective coating may be taken into account. The impact effectiveness of coating shall be documented.

E. Special Considerations

E 100 General

101 This subsection gives guidance on scenarios that shall be evaluated separately. Both the load effects and acceptance criteria are affected.

E 200 Pipe soil interaction

201 For limit states influenced by the interaction between the pipeline and the soil, this interaction shall be determined taking due account for all relevant parameters and the uncertainties related to these.

In general pipeline soil interaction depends on the characteristics of the soil and the pipeline, on the entire interaction history since and including laying and on the failure mode in question, which shall all be properly accounted for in the simulation of the pipeline soil interaction.

202 The main soil characteristics governing the interaction are the shear strength and deformation properties.

203 Pipeline characteristics of importance are submerged weight in all phases, diameter, stiffness, roughness of the pipeline surface, and initial embedment from installation which shall all be accounted for as relevant for the limit state in question.

204 All relevant load effects shall be considered. This includes:

- load duration and history effects (e.g. varying vertical reactions from installation laying pressures in possible combination with horizontal motions)
- variations in the unit weight of the pipe (e.g. empty, water filled and operation conditions)
- cyclic loading effects (both directly from pipe as well as hydrodynamic loads)

205 Calculation of soil resistance for a design situation shall be based on the worst case of high and low estimates of shear strength affecting the end result for the design situation, as described in Sec.3 C305. Where

best estimate and upper and lower bounds of the soil resistance are to be defined these shall all relate to the worst case shear strength definition, but reflect for all other uncertainties, such as assumptions of laying effects and uncertainties related to selection of calculation method.

206 Some soils have different resistance values for long term loading and for short term loading, related to the difference in drained and undrained behaviour and to creep effects in drained and undrained condition. This shall be taken into account.

207 For limit states involving or allowing for large displacements (e.g. lateral pull-in, pipeline expansion of expansion loops, global buckling or when displacements are allowed for on-bottom condition) the soil will be loaded far beyond failure, involving large non-linearities, remoulding of soil, ploughing of soil etc. Such non-linear effects and the uncertainties related to these shall be considered.

208 For pipelines that are buried (trenched and/or covered by gravel) and susceptible to global buckling the uplift resistance and possible increased axial resistance shall be considered. The possible effect of backfill material from trenching shall be considered.

209 Due to the uncertainties in governing soil parameters, load effects, idealization of calculation models etc., it is difficult to define universally valid methods for simulation of pipe soil interaction effects. The limitations of the methods used, whether theoretically or empirically based, shall be thoroughly considered in relation to the problem at hand. Extrapolation beyond documented validity of a method shall be performed with care, as shall simplifications from the problem at hand to the calculation model used. When large uncertainties exist, the use of more than one calculation approach shall be considered.

E 300 Global buckling

301 For load controlled global buckling, see D700.

302 Displacement or partially displacement controlled global buckling may be allowed. This implies that global buckling may be allowed provided that:

- pipeline integrity is maintained in post-buckling configurations (e.g. local buckling, fracture, fatigue etc.)
- displacement of the pipeline is acceptable.

Guidance note:

It is not sufficient to design HP/HT pipelines for global buckling based on “worst case” axial and lateral soil resistance combined with displacement controlled local buckling criteria only. These upper and lower bound soil resistance values will typically have a probability of exceedance in the order of a couple of per cent and will not alone prove a sufficient nominal failure probability. A more total evaluation of the failure probability is, hence, required.

---e-n-d---of---G-u-i-d-a-n-c-e---n-o-t-e---

303 The pipeline may buckle globally, either downwards (in a free span), laterally (“snaking” on the seabed), or vertically (as upheaval buckling of a buried pipeline or on a free-span shoulder of an exposed pipeline).

304 The following global buckling initiators shall be considered:

- trawl board impact, pullover and hooking
- out of straightness.

305 Recommended practice for structural assessment of high pressure/high temperature pipelines is given in DNV-RP-F110.

E 400 Free spanning pipelines and risers

401 Spanning risers and pipelines shall have adequate safety against local buckling, fatigue, fracture and ovality and these shall be documented.

402 Recommended practice for free spanning pipelines is given in DNV-RP-F105. Recommended practice for fatigue design of risers is given in DNV-RP-F204.

E 500 On bottom stability

501 The pipeline shall not move from its as-installed position. This does not include permissible lateral or vertical movements, thermal expansion, and a limited amount of settlement after installation. This applies for the entire lifetime of the pipeline (including metal loss due to corrosion or erosion). The stability of the pipeline shall be documented.

Guidance note:

The acceptance criterion on permissible movements may vary along the pipeline route. Examples of possible limitations to pipeline movements include:

- local buckling, fatigue and fracture of pipe
- deterioration/wear of coating
- geometrical limitations of supports
- distance from other pipelines, structures or obstacles.

---e-n-d---of---G-u-i-d-a-n-c-e---n-o-t-e---

502 For weight calculations of the pipe, the nominal wall thickness shall be reduced to compensate for the expected average weight reduction due to metal loss. For pipelines with minor corrosion allowance this reduction may be omitted and the nominal thickness used.

503 The submarine pipeline system shall have a specific gravity sufficient to avoid floatation. If a sufficient low probability of negative buoyancy is not documented, the following criterion applies:

$$\gamma_w \cdot \frac{b}{W_{sub} + b} \leq 1.00 \quad (5.37)$$

Where:

- γ_w = Safety factor on weight, 1.1
- b = buoyancy
- W_{sub} = Submerged weight

504 Pipelines shall have adequate safety against sinking. Special considerations shall here be made to mechanical components such as valves and Tee's. If the soil is, or is likely to be, liquefied, it shall be documented that the depth of sinking will be satisfactorily limited (either by the depth of liquefaction or by the build-up of vertical resistance during sinking).

Guidance note:

If the specific submerged weight of the water-filled pipe is less than that of the soil, then no further analyses are required to document safety against sinking.

---e-n-d---of---G-u-i-d-a-n-c-e---n-o-t-e---

505 Buried pipelines shall have adequate safety against floatation in soil.

506 When the pipeline is routed in areas that may be influenced by unstable slopes that could lead to slope failure and flow of soil that will impact the pipeline, the probability of such slope failures shall be evaluated. Any relevant slope failure triggering effect, such as wave loading, earthquake loading or man made activities (e.g. the pipe-laying itself), shall be considered. Possible flow rates and densities at the pipeline shall be evaluated for stability. If stability cannot be guaranteed by sufficient weight of the pipeline, by burial of the pipeline or by other means, re-routing of the pipeline shall be required.

507 The most unfavourable combination of simultaneously acting vertical and horizontal forces on the pipeline shall be considered. When determining this unfavourable combination, the variation in forces along the line, including directionality effects of waves and current, should be addressed.

508 Axial (longitudinal) stability shall be checked. The anode structural connection (when exposed to friction, e.g., pipelines without weight coating) shall be sufficient to sustain the anticipated friction force.

509 Pipeline movements due to thermal axial expansion, shall be allowed for near platforms/structures (e.g. at riser tie-in point) and where the pipeline changes direction (e.g. at offset spools). The expansion calculations shall be based upon conservative values for the axial frictional resistance.

510 In shallow water, the repeated loading effects due to wave action may lead to a reduction of the shear strength of the soil. This shall be considered in the analysis, particularly if the back fill consists of loose sand, and in general if the soil consists of silt or sand with high silt content. Both cases may be susceptible to liquefaction.

511 If the stability of the pipeline depends on the stability of the seabed, the latter should be checked.

512 Recommended practice for stability of pipelines exposed to wave and current loads is given in DNV-RP-F109.

E 600 Trawling interference

601 The submarine pipeline system shall be checked for all three loading phases due to trawl gear interaction, as outlined in Sec.4 E.

602 The acceptance criteria are dependent on the trawling frequency (impact) and the safety class.

603 Trawl pullover loads shall be checked in combination with other relevant load effects. Trawl pullover shall be combined with global buckling. Accumulation of damage due to subsequent trawling is not normally allowed.

604 Hooking loads shall be checked in combination with other relevant load effects. All relevant failures modes shall be checked.

605 Recommended practice for trawl and pipeline interference is given in DNV-RP-F111.

E 700 Third party loads, dropped objects

701 The submarine pipeline system shall be designed for impact forces caused by, e.g. dropped objects, fishing gear or collisions. The design may be achieved either by design of pipe, protection or means to avoid impacts.

702 The design criteria shall be based upon the frequency/likelihood of the impact force and classified as accidental, environmental or functional correspondingly, see D1000.

703 Recommended practice for risk assessment of pipeline protection is given in DNV-RP-F107.

E 800 Earth quakes

801 The submarine pipeline system shall have adequate resistance against earth quakes.

Guidance note:

The following scenarios shall typically be considered:

- Local buckling, collapse etc. of the pipeline due to seabed motions and movements
- Indirect effects (e.g. caused by movements of secondary structures)
- Failure of gravel supports
- Potential damage from mud-slides.

---e-n-d---of---G-u-i-d-a-n-c-e---n-o-t-e---

802 For design against earth quakes, reference is given to ISO 19901-2.

E 900 Thermal insulation

901 If the submarine pipeline system is thermally insulated,

- it shall be documented that the insulation is resistant to the combination of water, temperature and hydrostatic pressure.
- It should be documented that the resistant to oil and oil-based products, if relevant.
- It shall be documented that the required mechanical strength to external loads, as applicable.
- Degradation of the insulation during construction and operation shall be considered.

E 1000 Settings from plugs

1001 Recommended practice for loads from plugs is given in DNV-RP-F113.

F. Pipeline Components

F 100 General

101 This Subsection is applicable to pressure containing components (e.g. bends, flanges and connectors, Tee's, valves etc.) used in the submarine pipeline system. Supporting structure requirements are given in G.

102 Design of pipeline components shall be according to recognised codes combined with the additional requirements listed in Table 5-15.

103 Design of pipeline components shall also comply with the material, manufacturing and test requirements for components in Sec.8.

Table 5-15 Referenced standards for structural design of components		
<i>Component</i>	<i>Example of Design Codes¹⁾</i>	<i>Additional design requirements</i>
All Components listed below ²⁾	ASME VIII Division 2 / EN 13445 / PD 5500	F100
Induction Bends	ISO 15590-1	F200
Fittings	Tees: ASME B31.4, B31.8	F300
Flanges	ISO 15590-3/ ISO 7005-1 or NORSOK L005 / EN 1591-1	
Valves	ISO 14723	F400
Mechanical connectors	ASME VIII Division 2 / EN 13445 / PD 5500	
CP Insulating joints	ASME VIII Division 2 / EN 13445 / PD 5500	F500
Anchor flanges	N.A. see Note ²⁾	
Bolting	ASME VIII Division 2 / EN 13445 / PD 5500	
Pig traps	ASME VIII Division 2 / EN 13445 / PD 5500	F600
Repair clamps, repair couplings and hot taps	DNV-RP-F113	Hot tap's: API RP 2201
1) Other recognised equivalent codes may be used.		
2) Required in case the code used in the design of a component does not take into account forces other than the internal pressure, see 106.		

104 All pressure containing components used in the submarine pipeline system should represent at least the same safety level as the connecting riser/pipeline section.

105 The design pressure for the pipeline component shall be harmonised with the design pressure of the submarine pipeline systems.

Guidance note:

This implies that the design pressure for the component shall be selected such that it harmonises with the design and incidental pressure in the submarine pipeline system. Different design codes have different definitions of design pressure, and a thorough evaluation of this shall be performed.

---e-n-d---of---G-u-i-d-a-n-c-e---n-o-t-e---

106 The component shall be designed to accommodate the loading from the connected pipeline section and vice versa with appropriate safety. If the code used in the design of a component does not take into account forces other than the internal pressure, additional evaluations, e.g. FE analyses according to; ASME VIII Division 2 / EN 13445 / PD 5500, are required in order to address the maximum forces that can be transferred to the component from the connecting pipeline sections under installation and operation.

The strength shall, as a minimum be:

- equivalent to the connecting pipeline, or
- sufficient to accommodate the most probable maximum 100-year load effect that will be transferred to the component from the connecting pipeline under installation and operation, see Sec.4.

107 The use of other codes for structural design may require code breaks. These do only apply for design as the overall applicable code shall be this standard.

Guidance note:

It is recommended that the code break between line pipe and the relevant component standard is located at the component weld neck, see Figure 4. The code for pipeline component shall include pipe sections affected by the presence of the component.

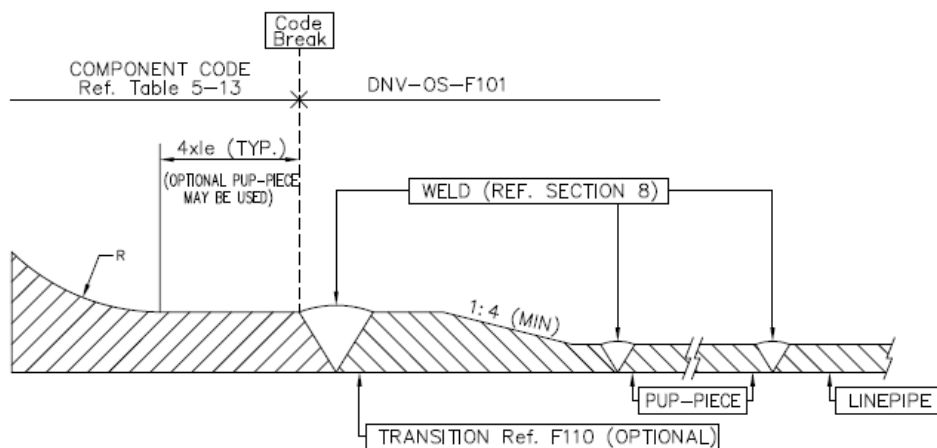

Figure 4
Code breaks between the line pipe and component connection

This pipe section should be minimum 4 times the elastic length of the pipeline section at code break, ref. DNV-RP-C203 Appendix D. The length may be reduced provided detailed analyses shows nominal pipe section stresses at shorter length.

The elastic length is defined as:

$$l_e = \frac{\sqrt{rt}}{\sqrt[4]{3(1-\nu^2)}} \quad 5.38$$

where

- r = radius to mid surface of the pipeline dimension,
- t = Wall thickness of the pipeline,
- ν = Poisson's ratio.

---e-n-d---of---G-u-i-d-a-n-c-e---n-o-t-e---

108 The load scenarios as described in Sec.4 as well as particular loads associated with the component shall be analysed. This implies that also external hydrostatic pressure shall be considered in the design with respect to both strength and internal leakage when relevant.

109 For material susceptible to HISC, see Sec.6 D500.

110 Sealing systems should be designed to allow testing without pressurising the pipeline.

111 The pigging requirements in B111 and Sec.3 D102 shall be considered for the component.

112 Transitions in C-Mn and low alloy steels where the nominal material thickness or yield stress is unequal shall be in accordance with ASME B 31.8 Appendix I, Figure I-5 or equally recognised codes. Transition in C-Mn linepipe by means of an external or internal taper shall be minimum 1:4. If transitions to these requirements are not feasible, a transition piece shall be inserted.

113 Transitions in duplex stainless steels and 13Cr martensitic stainless steels shall be such that the local stresses will not initiate HISC. Recommended practice for design of duplex stainless steels is given in DNV-RP-F112.

114 Internal transitions between different wall thicknesses and internal diameters for girth welds in pipes of equal SMYS may be made in the base material provided radiographic examination only is specified.

115 For welds to be examined by ultrasonic testing, transition tapering in the base material should be avoided. If tapering is unavoidable the pipe ends shall be machined to provide parallel external and internal surfaces before the start of the taper. The length of the parallel surfaces shall at least be sufficient to allow scanning from the external surface and sufficient for the required reflection off the parallel internal surface.

116 Specifications for installation and make-up of the component shall be established.

117 For pressure testing requirements of components, see Sec.8.

F 200 Induction bends

201 This Standard does not provide any limit state criteria for pipeline bends.

Guidance note:

Bends exposed to bending moments behave differently from straight pipes. Ovalisation becomes the first order of deformation and changes the stress pattern considerably compared to straight pipes.

---e-n-d---of---G-u-i-d-a-n-c-e---n-o-t-e---

202 As an alternative to recognised codes the following simplified Allowable Stress Design (ASD) check may be used provided that:

- The pressure containment criterion in D200 is fulfilled.
- The applied moment and axial load can be considered displacement controlled.
- The bend is exposed to internal over pressure or that the bend has no potential for collapse. This can be considered fulfilled if the system collapse design capacity is three times the external overpressure in question. The external pressure differential for the collapse limit state, $p_e - p_{min}$, shall hence be multiplied by a factor of 3 in Eq 5.14.
- That the imposed shape distortion (e.g. ovalisation) is acceptable.

The ASD criteria read:

$$\sigma_e \leq \eta \cdot f_y \quad (5.39)$$

$$|\sigma_i| \leq \eta \cdot f_y \quad (5.40)$$

where

$$\sigma_e \leq \sqrt{\sigma_h^2 + \sigma_i^2 - \sigma_h \cdot \sigma_i + 3 \cdot \tau_{hl}^2} \quad (5.41)$$

$$\sigma_h = (p_i - p_e) \frac{D - t_2}{2 \cdot t_2} \quad (5.42)$$

$$\sigma_i = \frac{N}{\pi \cdot (D - t_2) \cdot t_2} + \frac{M}{\frac{\pi \cdot (D^4 - (D - 2 \cdot t_2)^4)}{32 \cdot D}} \quad (5.43)$$

η = usage factor as given by Table 5-16

p_i = design pressure in line with ISO 13623

N = pipe wall force

M = bending moment, the most critical of tensile or compressive side shall be used.

Table 5-16 Usage factors for equivalent stress check			
	<i>Safety class</i>		
	<i>Low</i>	<i>Medium</i>	<i>High</i>
η	1.00	0.90	0.80

Guidance note:

The ovalisation of the bend has typically to be determined by finite element calculation. The acceptable distortion will typically be governed by the bullet points in D900.

---e-n-d---of---G-u-i-d-a-n-c-e---n-o-t-e---

F 300 Fittings

301 Tees shall be of the extruded outlet, integral reinforcement type. The design shall be according to ASME B31.4, B31.8 or equivalent.

302 Bars of barred tees should not be welded directly to the high stress areas around the extrusion neck. It is recommended that the bars transverse to the flow direction are welded to a pup piece, and that the bars parallel to the flow direction are welded to the transverse bars only. If this is impracticable, alternative designs should be considered in order to avoid peak stresses at the ends.

303 Wyes- and tees where the axis of the outlet is not perpendicular to the axis of the run (lateral tees) shall not be designed to ASME B31.4 or B31.8, as these items require special consideration, i.e. design by finite element analysis.

304 Standard butt welding fittings complying with ANSI B16.9, MSS SP-75 or equivalent standards may be used provided that:

- the actual bursting strength of the fitting is demonstrated to exceed that of the adjoining pipe
- the fitting is demonstrated to be able to accommodate the maximum forces that can occur in the pipeline in accordance with A105.

305 Branch welding fittings shall not be used when exceeding the maximum of 2 inches (2 3/8”) or an intersection angle of 72°.

F 400 Valves

401 The design shall ensure that internal gaskets are able to seal, and shall include a documented safety margin which is valid during all relevant pipeline operating conditions. Sealing will be sensitive to internal deflections, enlargement of gaps and changes in their support conditions. Valve operation will be sensitive to friction and clearances.

402 Consideration should be given to requirements for durability when exposed to abrasive material (e.g. weld scale, sand etc.) or to fire loads.

403 Valves with requirements for fire durability shall be qualified by applicable fire tests. Reference may be made to API 6FA and ISO 10497 for test procedures.

404 Valve control systems and actuators shall be designed and manufactured in accordance with recognised standards. The valve actuator specification should define torque requirements for valve operation, with a suitable safety margin to accommodate deterioration and friction increase during service.

405 If the code or standard used for design of a component does not take into account the possibility for internal leakage due to forces transferred to the component from the connecting pipeline sections, the additional calculations or qualification tests shall be performed.

F 500 Insulating joints

501 CP insulating joints shall be of the boltless, monolithic coupling type and shall be provided with a double seal system.

502 Insulating joints shall be fitted with pup pieces with mechanical properties and dimensions identical to that of the adjoining pipeline.

503 Insulating joints shall be capable of meeting the test requirements given in Sec.8 B900 and to withstand the effects of the environment without loss of performance.

504 To protect insulating joints and CP equipment from lightning effects, lightning protection shall be installed. Surge arrestors should be mounted across insulating joints and output terminals of D.C. voltage sources. Such measures should take into account the need for potential equalisation between the pipeline, anodes, power supplies, reference electrodes, etc. during lightning strikes. Alternative devices to the spark gap type can be used if documented to be reliable.

505 Bolting shall meet the requirements of Sec.6 C400.

506 All elastomeric materials used shall have a documented performance. The sealing materials shall have documented decompression, creep and temperature properties. O-ring seals shall be resistant to explosive decompression and AED certified. AED certification is not required for seals other than O-rings, provided they are enclosed in a completely confined space.

Sealing surfaces exposed to sea water shall be made of materials resistant to sea water at ambient temperature.

507 The insulating materials, including dielectric strength, compressive strength and suitability for use at the design temperatures shall be documented by testing in accordance with ASTM D 695.

F 600 Pig traps

601 The design of closures and items such as nozzle reinforcements, saddle supports, vent- kick and drain branches shall comply with the applied design standard.

602 Closures shall be designed such that the closure cannot be opened while the pig trap is pressurised. An interlock arrangement with the main pipeline valve should be provided.

G. Supporting Structure

G 100 General

101 Structural items such as support and protective structures that are not welded onto pressurized parts are considered as structural elements.

102 Steel structural elements shall be designed according to DNV-OS-C101 Design of Offshore Steel Structures, General (LRFD method).

G 200 Pipe-in-pipe and bundles

201 For pipe-in-pipe and bundle configurations, advantage may be taken of other loading conditions, e.g. pressure containment for the outer pipe. When determining the safety class, advantage may also be taken on the reduced failure consequences compared to those of ordinary pipelines.

Guidance note:

See Sec.13 for discussion on pipe-in-pipe.

---e-n-d---of---G-u-i-d-a-n-c-e---n-o-t-e---

202 The combined effective force for a pipe-in-pipe or a bundle may be calculated using the expression in Sec.4 G400 for each component and summing over all components. The external pressure for each component shall be taken as the pressure acting on its external surface, i.e. the pressure in the void for internal pipes. Release of effective axial force by end expansions, lateral and/or vertical deformations or buckling depends on how the pipes may slide relatively to each other. Therefore, analysis of cases where the effective axial force is important, such as analysis of expansion, buckling and dynamics, requires accurate modelling of axial restraints such as spacers, bulkheads etc.

G 300 Riser supports

301 The riser supports should be designed against the possible modes of failure with at least the same degree of safety as that of the riser they support. However, if safety considerations indicate that the overall safety is increased by a reduction of the failure load of certain supports, such considerations may govern the support design (weak link principle).

302 For bolted connections, consideration shall be given to friction factors, plate or shell element stresses, relaxation, pipe crushing, stress corrosion cracking, galvanic corrosion, fatigue, brittle failure, and other factors that may be relevant.

303 For supports with doubler and/or gusset plates consideration shall be given to lamellar tearing, pull out, element stresses, effective weld length, stress concentrations and excessive rotation. See also B108 through B111.

304 In clamps utilising elastomeric linings, the long-term performance of the material with regard to creep, sea water and air or sun light resistance shall be determined.

G 400 J-tubes

401 An overall conceptual evaluation shall be made in order to define the required:

- safety class
- impact design
- pressure containment resistance.

402 The J-tube shall be designed against the failure modes given in D100.

Guidance note:

401 above includes evaluation of whether the j-tube shall be designed for the full design pressure and to which safety class (i.e. hoop stress usage factors). The J-tube concept may e.g. be based on “burst disc” which will imply that a lower pressure containment resistance shall be governing. Other relevant evaluations may be J-tube pull-in forces, external impact, corrosion etc.

---e-n-d---of---G-u-i-d-a-n-c-e---n-o-t-e---

403 The J-tube spools should be joined by welding.

G 500 Stability of gravel supports and gravel covers

501 This applies to all types of gravel supports and covers, such as free span supports for installation and operating phases (excessive bending and fatigue), separation and pipeline stabilisation at crossings, suppressing of upheaval buckling, axial restraints/locking, stabilisation of pipeline etc.

502 The design of the gravel supports and covers shall consider the consequence of failure.

503 The design of the gravel supports and covers shall consider:

- weight of gravel supports and/or covers and pipeline
- loads imposed by pipeline (e.g. due expansion)
- seabed slope, both longitudinal and horizontal
- uncertainty in soil characteristics
- resistance against hydrodynamic loads
- slope failure (e.g. due to earthquakes)
- uncertainty in survey data
- subsea gravel installation tolerances, both horizontal and vertical.

H. Installation and Repair

H 100 General

101 The linepipe transportation should comply with the requirements of API5L and API5LW.

102 The pipeline strength and stability shall be determined according to D and E above.

Guidance note:

According to this standard, equivalent limit states are used for all phases. Hence the design criteria in this section also apply to the installation phase. Installation is usually classified as a lower safety class (safety class low) than operation, corresponding to lower partial safety factors (higher failure probability).

---e-n-d---of---G-u-i-d-a-n-c-e---n-o-t-e---

103 The design analysis for the submarine pipeline system shall include both installation and repair activities, in order to ensure that they can be installed and repaired without suffering damage or requiring hazardous installation or repair work.

104 The design shall verify adequate strength during all relevant installation phases and techniques to be used, including:

- initiation of pipe laying operation
- normal continuous pipe laying
- pipe lay abandonment and pipeline retrieval
- termination of laying operation
- tow out operations (bottom tow, off-bottom tow, controlled depth tow and surface tow)
- pipeline reeling and unreeling
- trenching and back filling
- riser and spool installation
- tie-in operations
- landfalls.

105 The configuration of pipeline sections under installation shall be determined from the laying vessel to the final position on the seabed. The configuration shall be such that the load effect levels are acceptable when all relevant effects are taken into account. Discontinuities due to weight coating, buckle arrestors, in-line assemblies etc. shall be considered.

106 The variation in laying parameters that affect the configuration shall be considered. An allowed range of parameter variation shall be established for the installation operation.

107 Critical laying parameters shall be determined for the installation limit condition, see Sec.4 C600 and Sec.10 F100.

108 Configuration considerations for risers and pipelines shall also be made for other installation and repair activities, and the allowed parameter variations and operating limit conditions shall be established.

109 If the installation and repair analyses for the submarine pipeline system show that the required parameters cannot be obtained with the equipment to be used, the submarine pipeline system shall be modified accordingly.

110 The flattening due to a permanent bending curvature, together with the out-of-roundness tolerances from fabrication of the pipe shall meet the requirements defined in D1100.

H 200 Pipe straightness

201 The primary requirement regarding permanent deformation during construction, installation and repair is the resulting straightness of the pipeline. This shall be determined and evaluated with due considerations of effects on:

- instability
- positioning of pipeline components e.g. valves and Tee-joints
- operation.

202 The possibility of instability due to out of straightness during installation (twisting) and the corresponding consequence shall be determined.

203 If in-line assemblies are to be installed potential rotation of the pipe due to out of straightness shall be controlled such that the load effects are acceptable and no damage to the pipeline or the in-line assembly occurs, and positioned on the seabed within defined limits.

204 The above equations only consider rotation due to residual strain from installation along a straight path. Other effects can also give rotation (curved lay route, eccentric weight, hydrodynamic loads, reduced rotational resistance during pulls due to lateral play/elasticity in tensioners/pads/tracks etc.) and need to be considered.

205 Instability during operation, due to out of straightness caused by the installation method and the corresponding consequences, shall be determined. Residual stresses affecting present and future operations and modifications shall also be considered.

206 The requirement for straightness applies to the assumed most unfavourable functional and environmental load conditions during installation and repair. This requirement also applies to sections of a pipeline where the strains are completely controlled by the curvature of a rigid ramp (e.g. stinger on installation vessel), whether or not environmental loads are acting on the pipe.

Guidance note:

Rotation of the pipe within the tensioner clamps of the pipe due to elasticity of the rubber and slack shall be included in the evaluation of the rotation.

---e-n-d---of---G-u-i-d-a-n-c-e---n-o-t-e---

H 300 Weight coating

301 Concrete crushing due to excessive compressive forces for static conditions in the concrete during bending at the overbend is not acceptable. See E900 for thermal insulation.

SECTION 6

DESIGN - MATERIALS ENGINEERING

A. General

A 100 Objective

101 This section provides requirements and recommendations to the selection of materials for submarine pipeline systems and to the external and internal corrosion control of such systems. Also covered is the specification of linepipe, pipeline components, coatings and cathodic protection. Finally, general considerations for fabrication applicable to the design phase are addressed.

102 The purpose of performing materials selection is to assess the feasibility of different candidate materials (including CRA's) to meet functional requirements for linepipe and for other components of a pipeline system. It may also include a cost comparison between candidate materials, including the calculated costs for operation and any associated risk cost (see D701). This activity is generally carried out during conceptual design of submarine pipeline systems.

A 200 Application

201 This section is applicable to the conceptual and design phases for submarine pipeline systems. It contains both normative requirements and information. (Sub-sections containing only informative text are indicated 'Informative' in heading).

202 Functional requirements for materials and manufacturing procedures for linepipe and pipeline components are contained in Sec.7 and 8, respectively. Manufacture and installation of systems for external corrosion control is addressed in Sec.9. Sec.9 also contains functional requirements to any concrete coating.

A 300 Systematic review

301 The overall requirement to systematic review in Sec.2 will for this section imply:

- Identification and evaluation of threats, the consequences of single failures and series of failures in the pipeline system applicable for the material selection and corrosion protection philosophy.
- Identification and evaluation of needs for supplementary requirements defined in this standard.
- Identification and evaluation of needs for supplementary requirements not accounted for in this standard. E.g. for CRA materials, and in particular for lined and clad pipes, it is possible that project specific requirements and design assumptions lead to requirements and technical solutions that are not fully accounted for in this standard.
- Review of potential Contractors, evaluation of their capabilities and identification of special needs, e.g. manufacturing procedure qualification, technical audits, follow-up during manufacturing, etc.

A 400 Documentation

401 The selection of materials during conceptual and/or detailed design shall be documented, preferably in a "Materials Selection Report", referring to the requirements and recommendations in this section, including use of CRAs, corrosion allowance and provisions for internal corrosion control. In the material selection document design premises for materials selection should be identified, making reference to the design basis and any other relevant project documents, together with the applicable codes and standards.

402 Any requirements and conditions on pipeline fabrication and operational procedures used as the basis for materials selection shall be duly high-lighted in the document to ensure that they are adequately transferred into these phases of the pipeline.

Guidance note:

The internal corrosion control of pipelines carrying potentially corrosive fluids based on chemical treatment is much based on conditions for periodic cleaning, corrosion monitoring and inspection of the integrity of the pipeline which are not always defined in the project design basis and need to be verified by the operator of the pipeline.

---e-n-d---of---G-u-i-d-a-n-c-e---n-o-t-e---

403 As a result of design activities, specifications of linepipe material, pipeline components (including bolts and nuts), pipeline coatings (including field joint coating and any concrete coating), anode manufacture and installation shall further be prepared as separate documents. Moreover, the design documentation shall include a cathodic protection design report.

B. Materials Selection for Linepipe and Pipeline Components

B 100 General

101 Materials for pipeline systems shall be selected with due consideration of the fluid to be transported, loads, temperature and possible failure modes during installation and operation. The selection of materials shall ensure compatibility of all components of the pipeline system. The following material characteristics shall be considered:

- mechanical properties
- hardness
- fracture toughness
- fatigue resistance
- weldability
- corrosion resistance.

102 Materials selection shall include identification of the following supplementary requirements for linepipe given in Sec.7 I as required:

- supplementary requirement S, H₂S service (see B200)
- supplementary requirement F, fracture arrest properties (see B407)
- supplementary requirement P, linepipe exposed to plastic deformation exceeding the thresholds specified in Table 5-12 (see B408 and 409)
- supplementary requirement D, more stringent dimensional requirements (see B403)
- supplementary requirement U, increased utilisation (see B410).

103 The mechanical properties, chemical composition, weldability and corrosion resistance of materials used in components shall be compatible with the part of the pipeline system where they are located. Low internal temperatures due to system depressurisation shall be considered during the material selection.

B 200 H₂S service

201 Pipelines to route fluids containing hydrogen sulphide (H₂S) shall be evaluated for H₂S service (also referred to as sour service) according to ISO 15156. For all pipeline components exposed to such internal fluids, materials shall be selected for compliance with this standard. For materials specified for H₂S service in ISO 15156, specific hardness requirements always apply. These are applicable both to manufactured materials as-delivered after manufacture and after fabrication (e.g. welding). For certain materials, restrictions for manufacture (e.g. heat treatment) and fabrication (e.g. cold forming) apply).

202 Any materials to be used that are not covered by ISO 15156 (e.g. C-Mn and low alloy steels with SMYS > 450 MPa, 13Cr martensitic stainless steels), shall be qualified according to the said standard. The same applies if a material specified for H₂S service is to be used beyond the conditions specified (e.g. max. hardness). In accordance with ISO 15156-2/3, the pipeline operator shall verify and retain the qualification records in case the testing was initiated by a contractor or supplier.

Guidance note:

Purchaser may consider to specify SSC testing of material grades meeting all requirements for H₂S service in ISO 15156 as a part of a program for pre-qualification of linepipe manufacturing or pipeline installation procedures. For such testing, the methods and acceptance criteria in ISO 15156-2/3 apply.

---e-n-d---of---G-u-i-d-a-n-c-e---n-o-t-e---

203 ISO 15156, Sec.1, states that the standard is only applicable “to the qualification and selection of materials for equipment designed and constructed using conventional elastic design criteria”. Any detrimental effects of induced loading will only apply if these are imposed during exposure to an H₂S-containing environment. ISO 15156 is thus not required to be fulfilled if H₂S is not present (e.g. for manufacture and installation of pipelines). Any restrictions for maximum allowable strain during operation are beyond the scope of this standard.

204 Supplementary requirements to H₂S service in this standard are given in Sec.7 I100 and Sec.8 C600.

B 300 Corrosion resistant alloys (informative)

301 Type 13Cr martensitic stainless steels (i.e. proprietary alloys developed for oil/gas pipelines) are generally considered fully resistant to CO₂-corrosion, provided welds have adequate PWHT. 22Cr and 25Cr duplex stainless steel and austenitic CRAs are also fully resistant and do not require PWHT. Duplex (ferritic-austenitic) and martensitic stainless steels may be less tolerant than C-Mn steel to well stimulation acids. Corrosion inhibitors for such acids developed for C-Mn steels may not be effective for CRAs.

302 Under conditions when water, oxygen and chloride can be present in the fluid, e.g. water injection, stainless steels can be susceptible to localised corrosion. Hence, the corrosion resistance shall be considered for each specific application. For special applications, corrosion testing should be considered to qualify the material for the intended use.

303 Alloy 625 (UNS N06625) is generally considered immune to ambient temperature seawater. Also type 25Cr duplex (e.g. UNS S32750/S32760) are generally resistant to ambient temperature seawater but require more stringent control of microstructure in base material and weld, consequently corrosion testing are often included for the qualification of manufacturing and fabrication procedures of these materials. Type 22Cr duplex, AISI 316 and Alloy 825 (UNS N08825) are not resistant to corrosion by raw seawater but are applicable for components exposed to treated seawater (deoxygenated to max. 10 ppb and max. 100 ppb as max monthly and daily residual concentrations of oxygen). For the latter materials, corrosion testing is not normally included in specifications for manufacture and fabrication.

304 Duplex and martensitic stainless steel linepipe and pipeline components require special considerations of the susceptibility of environmentally assisted cracking, primarily (HISC), see D502.

Guidance note:

In particular concerns of HISC apply to material subjected to plastic straining during installation, commissioning (in particular pressure testing) and operation with cathodic protection applied. PWHT is known to reduce the HISC susceptibility of welds for 13Cr martensitic stainless steel. Recommended practice for duplex stainless steel and HISC design is given in DNV-RP-F112.

---e-n-d---of---G-u-i-d-a-n-c-e---n-o-t-e---

305 In addition to resistance to internal corrosion and environmentally assisted cracking, the following major parameters shall be considered:

- mechanical properties
- ease of fabrication, particularly weldability.

Guidance note:

Procurement conditions such as availability, lead times and costs should also be considered.

---e-n-d---of---G-u-i-d-a-n-c-e---n-o-t-e---

B 400 Linepipe (informative)

401 Acceptance criteria and inspection requirements for linepipe, including pipe mill manufacturing welds, are given in Sec.7, with supplementary requirements specified in Sub-section I. Additional information, relevant for the selection and specification of linepipe is provided below.

Uniform elongation

402 Uniform elongation will in many cases be more relevant than elongation-at-break. Uniform elongation is the plastic deformation that takes place before necking starts. With information of the uniform elongation for a material it will be possible to more accurately determine how much safety margin is in a structure.

The uniform elongation can be determined by taking the total deformation at maximum load (i.e. the highest point of the stress-strain curve) and subtracting the elastic deformation (i.e. draw a line parallel to the initial loading curve down from the high point).

Dimensional tolerances

403 The most prominent benefit of specifying Supplementary requirement D is the eased fit-up prior to welding. Improved fit-up implies reduced stress concentrations and improved structural integrity. The tolerances specified in Sec.7 I400 are considered to be in the uppermost range of what may be achieved by reputable pipe mills. Stricter tolerances and additional requirements such as e.g. pipe eccentricity may be specified for further improvements, but may be costly as machining may be required. Supplementary requirement D is also beneficial when the pipe is exposed to high plastic straining due to reduced possibility for local buckling (reduced wall thickness difference between two adjoining pipes).

Corrosion testing of the CRA material of clad or lined linepipe

404 For Alloy 625 (UNS N06625) clad or lined pipe specified to be seawater resistant, testing according to ASTM G48, Method A, should be considered, with acceptance criteria as for 25Cr duplex, see Sec.7 C409.

Gripping force of lined linepipe

405 The gripping force (see Sec.7 D510) should be determined with due consideration of the project requirements, especially the level of installation and operational bending stresses. If no particular requirements are identified, the requirement should be based on the gripping force obtained during MPQT.

Influence of coating application on mechanical properties

406 Pipe tensile properties may be affected by high temperature during coating application. During pipe coating, including field coating, the pipes might be exposed to temperatures up to approximately 250°C. For TMCP processed pipes and cold formed pipes not subjected to further heat treatment mechanical properties may change due to strain aging, causing e.g. increased yield stress. This may further affect the critical defect size considerably if the pipe is strained above the yield stress.

Fracture arrest properties

407 Supplementary requirements to fracture arrest properties (F) are given in Sec.7 I200 and are valid for gas pipelines carrying essentially pure methane up to 80% usage factor, up to a pressure of 15 MPa, 30 mm wall thickness and 1120 mm diameter.

For conditions outside the above limitations the required fracture arrest properties should be based on calculations which reflect the actual conditions or on full-scale tests. The fracture toughness required to arrest fracture propagation for rich gas, i.e. gas mixtures that enter the two-phase state during decompression can be much higher than for essentially pure methane.

Calculations should be carried out by use of the Battelle Two Curve Method (TCM) and the appropriate correction factor for calculated required Charpy values ≥ 95 J. It is strongly recommended that the Battelle TCM is calibrated by use of data from full-scale test which are as close as possible to the actual pipeline conditions with regard to gas pressure, pipeline dimensions and gas composition. Although the Battelle TCM is based on physical models of the speed of crack propagation and the speed of decompression, it includes constants that are based on fitting data and calculations within a limited range of test conditions.

Reeling of longitudinally welded pipes and clad pipes

408 Due to the limited field experience, special considerations should be made for longitudinally welded pipes to ensure that both the longitudinal weld, heat affected zone and base material of such pipes are fit for intended use after significant straining.

409 It is recommended that the weld metal strength of the pipe longitudinal weld overmatches the strength of the base material. It is further recommended to have a limited cap reinforcement of the longitudinal weld in order to avoid strain concentrations.

Supplementary requirement U - Qualification in retrospect

410 The Purchaser may in retrospect upgrade a pipe delivery to be in accordance with Supplementary requirement U (requirements to mechanical testing are given in Sec.7, I500). In case of more than 50 test units it must be demonstrated that the actual average yield stress is at least two (2.0) standard deviations above SMYS. If the number of test units is between 10 and 20, the actual average yield stress should as a minimum be 2.3 standard deviations above SMYS, and 2.1 if the number of test units are between 21 and 50. It is not allowed to upgrade the SMYS reflecting the next material grade.

B 500 Pipeline components (informative)

501 Materials for components should be selected to comply with internationally recognised standards meeting the requirements given in Sec.7 and Sec.8. Modification of the chemical composition given in such standards may be necessary to obtain a sufficient combination of weldability, hardenability, strength, ductility, toughness and corrosion resistance.

502 A component should be forged rather than cast whenever a favourable grain flow pattern, a maximum degree of homogeneity, and the absence of internal flaws are of importance.

503 For component material delivered in the quenched and tempered condition, the tempering temperature should be sufficiently high to allow effective post weld heat treatment during later manufacture / installation. The minimum tempering temperature should, if lower than 610°C, be specified by the purchaser.

If welds between the component and other items such as linepipe are to be post weld heat treated at a later stage, or if any other heat treatment is intended, a simulated heat treatment of the test piece should, if required, be specified by the purchaser.

504 If the chemical composition and the delivery condition of components require qualification of a specific welding procedure for welding of the joint between the component and the connecting linepipe, then the component should be fitted with pup pieces of the linepipe material in order to avoid field welding of these components.

Alternatively, rings of the component material should be provided for welding procedure qualification of the field weld.

505 Particular consideration should be given to the suitability of elastomers and polymers for use in the specific application and service conditions.

B 600 Bolts and nuts

601 For selection of bolting materials, see Sec.8 C500, plus B603 and B604 of this Section.

602 When bolts and nuts shall be used at elevated temperature strength de-rating shall be applied, see Sec.5 C300. See also guidance note in Sec.8 C502.

603 Stainless steel according to ASTM A193/ASTM A320 grade B8M (type AISI 316) is applicable but requires efficient cathodic protection for subsea use. UNS N06625 or other Ni-based solution hardening alloys with equivalent or higher PRE are applicable as subsea bolting material without cathodic protection. These bolts shall only be used in the solution annealed condition (ASTM B446) or cold-worked to SMYS 720 MPa maximum. Restrictions for H₂S service according to ISO 15156 shall apply when applicable.

604 To restrict damage by HISC for low alloy and carbon steels, the hardness for any bolts and nuts to receive cathodic protection shall not exceed 35 HRC or 350 HV, as specified for the standard grades in Sec.8, Table 8-3. The same restriction shall apply for solution annealed or cold-worked type AISI 316 austenitic stainless steel and any other cold-worked austenitic alloys. Precipitation hardening Fe-or Ni-base alloys, duplex and martensitic stainless steels should not be specified as bolting material if subject to cathodic protection. For certification and traceability of bolts, see C400.

605 Any coating of bolts and nuts shall be selected with due considerations of how such coatings affect tensioning and as-installed properties.

Guidance note:

Zinc coating, phosphatising and epoxy based coatings are applicable; however, there have been concerns that hot-dip zinc coating may cause loss of bolt tensioning and that polymeric coatings may prevent efficient cathodic protection by electrically insulating the bolt from a cathodically protected surface. PTFE coatings have low friction coefficient and the torque has to be applied accordingly.

---e-n-d---of---G-u-i-d-a-n-c-e---n-o-t-e---

B 700 Welding consumables (informative)

Girth welds

701 Requirements to welding are covered in Appendix C. Requirements that are specific for pipeline installation welding are given in Sec.10. Below is provided guidance regarding the influence of weld metal strength on allowable defect size as determined by ECA (if applicable).

702 The requirement for welds to have strength level equal to or higher than (overmatching properties) the base material is to minimise deformation in the area adjacent to any possible defects.

703 For pipes exposed to global yielding, i.e. when girth welds are exposed to strain $\epsilon_{1,nom} \geq 0.4\%$, it is required to perform an ECA according to Appendix A. The ECA generally requires that the weld metal yield stress is matching or overmatching the longitudinal yield stress of the pipe. An ECA involving undermatching weld metal will require special considerations, see Appendix A.

Temperature effects

704 It must be noted that the reduction in yield stress at elevated temperature may be higher for the weld metal than the base material. Hence, undermatching may be experienced for high operation temperatures (e.g. snaking scenario). This is particularly relevant when welding clad or lined linepipe. Whenever such situations occur, it will be required to perform transverse all weld tensile testing of the weld metal and fracture toughness testing at the relevant temperature.

C. Materials Specification

C 100 General

101 Requirements to the manufacture of linepipe and pipeline components are covered in Sec.7 and Sec.8, respectively. This includes requirements to all relevant manufacturing steps from steel making to dispatch from the pipe mill or component manufacturing facility, but excluding any permanent external/internal coating.

C 200 Linepipe specification

201 A specification reflecting the results of the materials selection according to this section and referring to Sec.7, shall be prepared by the Purchaser. The specification shall state any options, additional requirements to and/or deviations from this standard pertaining to materials, manufacture, fabrication and testing of linepipe.

202 The material specification may be a Material Data Sheet referring to this standard.

203 The materials specification shall as a minimum include the following (as applicable):

- quantity (e.g., total mass or total length of pipe)
- manufacturing process (see Sec.7 A400)
- type of pipe (see Sec.7 A201)
- SMYS
- if the strain ageing effect achieved during external coating should be addressed (see B406)
- outside or inside diameter
- wall thickness
- whether data of the wall thickness variation (t_{max} and t_{min}) or the standard deviation in wall thickness variation shall be supplied to facilitate girth welds AUT (see App.E, B107)
- length and type of length (random or approximate)
- application of supplementary requirements (S, F, P, D or U), see B102 and B103
- delivery condition (see Sec.7, Table 7-1 and H200)
- minimum design temperature

- range of sizing ratio for cold-expanded pipe
- chemical composition for wall thickness > 25 mm (applicable to C-Mn steel pipe with delivery condition N or Q)
- chemical composition for wall thickness > 35 mm (applicable to C-Mn steel pipe with delivery condition M)
- if additional tensile testing in the longitudinal direction with stress strain curves shall be performed
- production tensile testing of base material at elevated temperatures is not required by this standard, however, if this is requested by Purchaser, temperature (e.g. maximum design temperature), acceptance criteria and test frequency shall be defined
- CVN test temperature for wall thickness > 40 mm
- liner/cladding material (UNS number)
- mechanical and corrosion properties of liner/cladding material
- “type” of seal weld for lined linepipe
- thickness of carrier pipe and liner/cladding material
- any project specific requirements to gripping force of lined linepipe
- if the ultrasonically lamination checked zone at the pipe ends shall be wider than 50 mm
- if diameter at pipe ends shall be measured as ID or D
- if pipes shall be supplied with other than square cut ends (see Sec.7 B336)
- if criteria for reduced hydrostatic test pressure, as given in Sec.7 E105, is fulfilled, and if it may be applied
- if the outside weld bead shall be ground flush at least 250 mm from each pipe end to facilitate girth welds AUT (see Sec.7 B338)
- if inside machining of pipe ends is applicable, and the distance from pipe end to tapered portion (see Sec.7 B339, and App.E B108)
- if pipes shall be supplied with bevel protectors, and in case of what type (see Sec.7 H300)
- if weldability testing is required
- if qualification testing shall be conducted after the pipe material has been heated to the expected coating temperature when fusion bonded epoxy is used (see B406 and B407)
- application of the alternative weld cap hardness of C-Mn steel pipe according to supplementary requirement S (see Sec.7 I107)
- if SSC testing shall be performed during MPQT for pipes conforming to supplementary requirement S
- if supplementary requirement P apply, the relevant straining for the installation process, possible corrective actions (e.g. “reel on and reel off twice”) and post installation conditions/operations introducing plastic deformation shall be specified.

C 300 Components specification

301 A specification reflecting the results of the materials selection according to this section and the pressure test philosophy in Sec.5 B200 and referring to Sec.8, shall be prepared by the Purchaser. The specification shall state any options, additional requirements to and/or deviations from this standard pertaining to materials, manufacture, fabrication and testing of the components.

302 The materials specification shall as a minimum include the following (as applicable):

- quantity (i.e the total number of components of each type and size)
- design standard
- required design life
- material type, delivery condition, chemical composition and mechanical properties at design temperature
- nominal diameters, D or ID, out of roundness and wall thickness for adjoining pipes including required tolerances
- bend radius, see Sec.8 B313
- type of component, piggable or not piggable
- gauging requirements, see Sec.10 I210
- minimum design temperature (local)
- maximum design temperature (local)
- design pressure (local)
- water depth
- pipeline operating conditions including fluid characteristics
- details of field environmental conditions
- external loads and moments that will be transferred to the component from the connecting pipeline under installation and operation and any environmental loads
- functional requirements
- material specification including, material type, delivery condition, chemical composition and mechanical properties at design temperature
- required testing
- required weld overlay, corrosion resistant or hardfacing
- if pup pieces of the linepipe material shall be fitted
- coating/painting requirements.

C 400 Specification of bolts and nuts

401 Bolts and nuts shall be supplied with certificates to EN 10204 Type 3.1 or ISO 10474 type 3.1.B. Bolts and nuts for pressure containing applications shall be marked for traceability to such certificates. Transfers of test results obtained by specific inspection on primary or incoming products shall not be acceptable for mechanical properties. Fasteners originating from different manufacturing lots shall not be commingled.

402 Bolts and nuts for pressure containing and main structural applications should be specified to have rolled threads.

403 Any coating of bolts shall be specified in the purchase document for bolting.

Guidance note:

Bolts to be installed continuously submerged in seawater shall be designed to receive cathodic protection and do not need any coating for corrosion control. Reference is made to B600 for more information regarding use of bolts and nuts exposed to cathodic protection. For bolts to be exposed in splash zone or atmospheric zone corrosion protective coating may be considered.

---e-n-d---of---G-u-i-d-a-n-c-e---n-o-t-e---

C 500 Coating specification

501 As a part of detailed design, project specific requirements to as-applied coating properties and to quality control of the manufacture of coating materials and of coating application (including coating for risers, see D600) shall be defined in a purchase specification.

502 The specification of linepipe coating, field joint coating and any weight coating shall include requirements to the qualification of coating materials, coating application and repair procedures, dimensions of the linepipe cut-back (including tolerances) and to documentation of inspection and testing.

Guidance note:

Cut-backs shall be defined to accommodate any AUT equipment.

---e-n-d---of---G-u-i-d-a-n-c-e---n-o-t-e---

503 For specific linepipe and field joint coating systems the minimum requirements in ISO 21809 (part 1-3) shall apply with some additional requirements given in Sec.9 B in this DNV standard. For concrete coating the minimum requirements in ISO 21809-5 shall apply with additional requirements given in Sec.9 C in this DNV standard.

504 Recommended practice for application of linepipe and field joint coating systems (some additional systems to those defined in ISO 21809) are given in DNV-RP-F106 and DNV-RP-F102.

Guidance note:

These RPs comply with and refers to ISO 21809 and give some additional requirements and guidance to coating design and quality control of application.

---e-n-d---of---G-u-i-d-a-n-c-e---n-o-t-e---

C 600 Galvanic anode specification

601 As a part of design, specifications for manufacture and installation of galvanic anodes shall be prepared. These documents shall define requirements to materials, properties of anodes and anode fastening (including any special provisions for electrical continuity), and associated quality control. Detailed requirements are given in Sec.9.

C 700 Concrete coating specification

701 If concrete coating is applicable, project specific requirements to concrete coating shall be defined in a purchaser specification as part of detail design. ISO 21809-5 gives requirements to information that shall be supplied by the purchaser and additional requirement given in C702-C703 shall be included. Requirements to materials and concrete coating application are specified in Sec.9.

702 The amount of reinforcement shall be designed for the specific project; i.e. take into account the actual installation, laying and operation conditions for the pipeline. The percentage of reinforcement specified in Sec.9 C should be considered as absolute minimum amounts.

703 Minimum shear resistance capacity between concrete coating and corrosion coating shall be specified by the offshore laying contractor and included in the concrete coating specification.

Guidance note:

For coal tar asphalt/coal tar enamel linepipe coating the effect of operating temperature (>40°C) on shear strength capacity should be considered to prevent axial sliding of pipeline inside concrete coating.

---e-n-d---of---G-u-i-d-a-n-c-e---n-o-t-e---

D. Corrosion Control

D 100 General

101 All components of a pipeline system shall have adequate corrosion control both externally and internally to avoid failures caused or initiated by corrosion.

Guidance note:

Any corrosion damage may take the form of a more or less uniform reduction of pipe wall thickness, but scattered pitting and grooving corrosion oriented longitudinally or transversally to the pipe axis is more typical. Stress corrosion cracking is another form of damage. Uniform corrosion and corrosion grooving may interact with internal pressure or external operational loads, causing rupture by plastic collapse or brittle fracture. Discrete pitting attacks are more likely to cause a pinhole leakage once the full pipe wall has been penetrated.

---e-n-d---of---G-u-i-d-a-n-c-e---n-o-t-e---

102 Pipeline systems may be exposed to a corrosive environment both internally and externally. Options for corrosion mitigation include use of corrosion protective coatings and linings, cathodic protection (externally only), and chemical treatment or fluid processing (internally only).

D 200 Corrosion allowance

201 For submarine pipeline systems a corrosion allowance may serve to compensate for internal and/or external corrosion and is mostly applied for control of internal or external pressure. For C-Mn steel components, a corrosion allowance may be applied either alone or in addition to some system for corrosion mitigation. However, for external corrosion protection of continuously submerged components, cathodic protection is mandatory and a corrosion allowance for external corrosion control is then superfluous.

Guidance note:

A requirement for wall thickness determined by installation forces and exceeding that needed for pressure containment at the initial design pressure, or wall thickness not needed for pressure containment due to a later down rating of operational pressure can be utilised for corrosion control but is not referred to in this document as a “corrosion allowance”.

A corrosion allowance is primarily used to compensate for forms of corrosion attack affecting the pipeline's pressure containment resistance, i.e. uniform attack and, to a lesser extent, corrosion damage as grooves or pits. Such damage is unlikely to affect the pipeline's pressure containment resistance but will cause a pinhole leak when the full wall thickness is penetrated. Any extra wall thickness will then only delay leakage in proportion to the increase in wall thickness.

---e-n-d---of---G-u-i-d-a-n-c-e---n-o-t-e---

202 The needs for, and benefits of, corrosion allowance shall be evaluated, taking into account the following factors as a minimum:

- design life and potential corrosivity of fluid and/or external environment
- expected form of corrosion damage (see Guidance note above)
- expected reliability of planned techniques and procedures for corrosion mitigation (e.g. chemical treatment of fluid, external coating, etc.)
- expected sensitivity and damage sizing capability of relevant tools for integrity monitoring, time to first inspection and planned frequency of inspection
- consequences of sudden leakage, requirements to safety and reliability
- any extra wall thickness applied during design for installation forces and not needed for control of internal and external pressure
- any potential for down-rating (or up-rating) of operating pressure.

203 An internal corrosion allowance of minimum 3 mm is recommended for C-Mn steel pipelines of safety class Medium and High carrying hydrocarbon fluids likely to contain liquid water during normal operation. For nominally dry gas and for other fluids considered as non-corrosive, no corrosion allowance is required.

204 An external corrosion allowance of minimum 3 mm is recommended for C-Mn steel risers of safety class Medium and High in the splash zone. An external corrosion allowance shall further be considered for any landfalls. For risers carrying hot fluids (> 10°C above normal ambient seawater temperature), a higher corrosion allowance should be considered, at least for the splash zone (see 602). Any allowance for internal corrosion shall be additional.

D 300 Temporary corrosion protection

301 The need for temporary corrosion protection of external and internal surfaces during storage and transportation shall be considered during design/engineering for later inclusion in fabrication and installation specifications. Optional techniques include end caps or bevel protectors, temporary thin film coating and rust protective oil/wax.

Guidance note:

Outdoor storage of unprotected pipes for a period of up to about a year will not normally cause any significant loss of wall thickness. However, superficial rusting may cause increased surface roughness affecting pipeline coating operations. Conditions for storage should be such that water will not accumulate internally, or externally at any supports. End caps may retain water internally if damaged or lost at one end, allowing entry of rain water or condensation. Temporary coating applied at coating cut-backs may interfere with pipeline girth welding.

---e-n-d---of---G-u-i-d-a-n-c-e---n-o-t-e---

302 The needs for corrosion protection during flooding shall be assessed for inclusion in installation specifications. Special precautions are required to avoid corrosion damage to CRA pipelines during system pressure testing using seawater. Type 13Cr linepipe may suffer superficial corrosion attack during outdoor storage.

Guidance note:

The use of a biocide for treatment of water for flooding is most essential (even with short duration) as incipient bacterial growth established during flooding may proceed during operation and cause corrosion damage (pipelines for dry gas are excluded). For uncoated C-Mn steel pipelines, an oxygen scavenger may be omitted since oxygen dissolved in sea-water will become rapidly consumed by uniform corrosion without causing significant loss of wall thickness. Film forming or “passivating” corrosion inhibitors are not actually required and may even be harmful. Type 13Cr steel is highly susceptible to damage by raw seawater or marginally treated seawater even at a short exposure period. Use of fresh water should be considered or seawater treated to a pH of 9 minimum.

---e-n-d---of---G-u-i-d-a-n-c-e---n-o-t-e---

D 400 External pipeline coatings (informative)

401 “Linepipe coating” (also referred to as “factory coating or “parent coating”) refers to factory applied external coating systems (mostly multiple-layer, with a total thickness of some millimetres) with a corrosion protection function, either alone or in combination with a thermal insulation function. Some coating systems may further include an outer layer for mechanical protection, primarily during laying and any rock dumping or trenching operations. Concrete coating for anti-buoyancy (weight coating, see Sec.9 C) is, however, not covered by the term linepipe coating.

402 “Field joint coating” (FJC) refers to single or multiple layers of coating applied to protect girth welds and the associated cut-back of the linepipe coating, irrespectively of whether such coating is actually applied in the field or in a factory (e.g. pipelines for reel laying and prefabricated risers). “Coating field repairs” refers to repairs of factory coating performed in the field (typically by the FJC contractor).

403 The linepipe (external) coating system should be selected based on consideration of the following major items:

- a) general corrosion-protective properties dictated by permeability for water, dissolved gases and salts, adhesion, freedom from pores, etc.
- b) resistance to physical, chemical and biological degradation leading to e.g. cracking or disbondment, primarily in service but also during storage prior to installation (temperature range and design life are decisive parameters)
- c) requirements for mechanical properties, primarily those related to adhesion and flexibility, during installation (min. temperature) and operation (max. temperature)
- d) coating system’s compatibility with specific fabrication and installation procedures, including field joint coating and coating field repairs
- e) coating systems compatibility with concrete weight coating (see Sec.9 C), if applicable
- f) coating system’s compatibility with CP, and capability of reducing current demand for CP, if applicable
- g) linepipe material’s compatibility with CP considering susceptibility to HISC; see B303
- h) linepipe material’s susceptibility to corrosion in the actual environment, including stress corrosion cracking in the atmospheric zone and any onshore buried zone
- i) environmental compatibility and health hazards during coating application, fabrication/installation and operation.

404 For thermally insulating coatings, properties related to flow assurance also apply; e.g. specific heat capacity, thermal conductivity and the degradation of such properties by high operating external pressure and internal fluid temperature.

405 Pipeline components should have external coatings matching the corrosion protective properties of those to be used for linepipe. If this is not practical, CP design may compensate for inferior properties. However, risks associated with HISC by CP shall be duly considered (see B304 and D502 Guidance note).

406 For the selection of FJC, the same considerations as for pipeline and riser coatings as in 403, 605 and 606 apply. In addition, sufficient time for application and cooling or curing is crucial during barge laying of pipelines.

407 For pipes with a weight coating or thermally insulated coating, the field joint coating (FJC) is typically made up of an inner corrosion protective coating and an in-fill. The objective of the in-fill is to provide a smooth transition to the pipeline coating and mechanical protection to the inner coating. For thermally insulated pipelines and risers, requirements for adequate insulating properties may also apply. The requirements and guidelines to FJC are also applicable to any field repairs of factory coating

408 The design and quality control of field joint coatings is essential to the integrity of pipelines in HISC susceptible materials, including ferritic-austenitic (duplex) and martensitic stainless steel. Recommended practice for design and quality control of field joint coatings is given in DNV-RP-F102.

D 500 Cathodic protection

501 Pipelines and risers in the submerged zone shall be furnished with a cathodic protection (CP) system to provide adequate corrosion protection for any defects occurring during coating application (including field joints), and also for any subsequent damage to the coating during installation and operation. The design of submarine pipeline CP systems shall meet the minimum requirements in ISO15589-2. Reference is given to DNV-RP-F103 for some additional amendments and guidelines.

Guidance note:

CP may be achieved using either galvanic (“sacrificial”) anodes, or impressed current from a rectifier. Galvanic anodes are normally preferred.

---e-n-d---of---G-u-i-d-a-n-c-e---n-o-t-e---

502 The CP systems shall be capable of suppressing the pipe-to-seawater (or pipe-to-sediment) electrochemical potential into the range -0.80 to -1.15 V rel. Ag/AgCl/ seawater. A less negative potential may be specified for pipelines in CRA materials.

Guidance note:

Potentials more negative than -1.15 V rel. Ag/AgCl/ seawater can be achieved using impressed current. Such potentials may cause detrimental secondary effects, including coating disbondment and HISC of linepipe materials and welds. Pipeline system components in high-strength steel, and particularly in martensitic or ferritic-austenitic (‘duplex’) stainless steel, subject to high local stresses during subsea installation activities (e.g. pre-commissioning) or operation can suffer HISC by CP, also within the potential range given above. Such damage is primarily to be avoided by restricting straining subsea by design measures. In addition, special emphasis should be laid on ensuring adequate coating of components that may be subject to localised straining. It is essential that the coating systems to be applied (i.e. factory applied coating and field joint coating) for materials that are known to be susceptible to HISC have adequate resistance to disbonding by mechanical effects during installation as well as chemical/physical effects during operation. Overlay welding of critical areas with austenitic CRA filler materials may be considered when organic coatings are not applicable. Thermally sprayed aluminium coating has also been applied for this purpose. Other measures to reduce or eliminate the risk of HISC include control of galvanic anodes by diodes and use of special anode alloys with less negative closed circuit potential. (These techniques require that the pipeline is electrically insulated from conventional CP systems on electrically connected structures). In case conventional bracelet anodes are still to be used, welding of anodes to any pressure containing components in these materials should be avoided.

---e-n-d---of---G-u-i-d-a-n-c-e---n-o-t-e---

503 Galvanic anode CP systems should be designed to provide corrosion protection throughout the design life of the protected object.

Guidance note:

As retrofitting of galvanic anodes is generally costly (if practical at all), the likelihood of the initial pipeline design life being extended should be duly considered.

---e-n-d---of---G-u-i-d-a-n-c-e---n-o-t-e---

504 Pipeline systems connected to other offshore installations shall have compatible CP systems unless an electrically insulating joint is to be installed. At any landfall of an offshore pipeline with galvanic anodes and with impressed current CP of the onshore section, the needs for an insulating joint shall be evaluated.

Guidance note:

Without insulating joints, some interaction with the CP system of electrically connected offshore structures cannot be avoided. As the design parameters for subsea pipelines are typically more conservative than that of other structures, some current drain from riser and pipeline anodes to the CP system of the connecting system cannot be avoided, sometimes leading to premature consumption. When the structure has a correctly designed CP system such current drain is not critical as the net current drain will decrease with time and ultimately cease; i.e. unless the second structure has insufficient CP.

---e-n-d---of---G-u-i-d-a-n-c-e---n-o-t-e---

505 Pipelines should be designed with a self-sustaining CP system based on bracelet anodes installed with a maximum distance of 300 m (in accordance with ISO 15589-2) and with electrical connections to the pipeline by pin brazing or aluminothermic welding of cable connections to the pipe wall. (See App.C E500).

For shorter pipelines (up to 30 km approximately), CP may be achieved by anodes installed on structures at the end of the pipeline (e.g. platform sub-structure, subsea template or riser base) electrically connected to the

pipeline. This concept requires, however, that the design and quality control of factory applied coatings, field joint coatings and coating field repairs are closely defined (e.g. as in DNV-RP-F106 and DNV-RP-F102). A recommended procedure to calculate the protective length of anodes on an adjacent structure is given in DNV-RP-F103.

Guidance note 1:

ISO 15589-2 gives an alternative procedure but, contrary to DNV-RP-F103, does not define the primary parameters to be used for calculation of the protective length.

---e-n-d---of---G-u-i-d-a-n-c-e---n-o-t-e---

Guidance note 2:

CP by anodes located on adjacent structures significantly reduces the cost of anode installation in case the pipeline installation concept would otherwise require anode installation offshore. Moreover, for buried pipelines in general and for hot buried lines in particular, the anode electrochemical efficiency and current output capacity increases since the anodes on such structures are freely exposed to seawater. The condition of such anodes can also be monitored. The concept of basing pipeline CP on anodes installed on adjacent structures further reduces the risk of HISC damage to pipelines in susceptible materials (e.g. martensitic and ferritic-austenitic stainless steels).

---e-n-d---of---G-u-i-d-a-n-c-e---n-o-t-e---

506 Bracelet pipeline anodes are to be designed with due considerations of forces induced during pipeline installation. For anodes to be installed on top of the pipeline coating, this may require use of bolts for tensioning or welding of anode tabs with pressure applied on the bracelet assembly during the mounting. Connector cables shall be adequately protected; e.g. by locating the cables to the gap between the anode bracelets and filling with a moulding compound.

507 A calculation procedure for pipeline CP design using conventional bracelet anodes and a maximum anode spacing of 300 m is given in ISO 15589-2 and in DNV-RP-F103.

Guidance note:

The latter document generally refers to ISO 15589-2 for design parameters and design procedures to be used and recommends some default values which represent minimum requirements that do not need to be verified by special considerations and testing. DNV-RP-F103 emphasizes the importance of coating design and quality control of coating application when defining the CP current reducing effects of such coatings. It further contains additional guidance to the CP design. For alternative design procedures, see 505 and 506 above.

---e-n-d---of---G-u-i-d-a-n-c-e---n-o-t-e---

508 The detailed engineering documentation of galvanic anode CP systems shall contain the following:

- design premises, including design life and reference to relevant project specifications, codes and standards
- calculations of average and final current demands for individual sections of the pipeline
- calculations of total anode net mass for the individual sections, to meet the mean current demand
- calculation of final current anode output to verify that the final current demand can be met for the individual sections of the pipeline (applies to a conventional bracelet anode concept with max. 300 m anode spacing)
- number of bracelet anodes for the individual pipeline sections, and resulting net anode mass to be installed on each section
- outline drawing(s) of bracelet anodes with fastening devices and including tentative tolerances
- calculations of pipeline metallic resistance to verify the feasibility of CP by anodes on adjacent structure(s) or a bracelet anode concept exceeding a spacing of 300 m in case any of these options apply (see DNV-RP-F103)
- documentation of CP capacity on adjacent installation(s) to be utilized for CP of pipeline, if applicable.

Guidance note:

The above requirements for documentation of CP design is an amendment to ISO 15589-2.

---e-n-d---of---G-u-i-d-a-n-c-e---n-o-t-e---

509 Recommended practice for CP design of pipeline system components with major surfaces in structural steel (e.g. riser bases) is given in DNV-RP-B401.

510 Design of any impressed current CP systems installed at land falls shall comply with ISO 15589-1. Requirements to electrically insulating joints are given in Sec.8 B800.

Guidance note:

Design of impressed current CP systems at landfalls is not covered by this standard. Some general guidance is given in ISO 15889.

---e-n-d---of---G-u-i-d-a-n-c-e---n-o-t-e---

D 600 External corrosion control of risers (informative)

601 For a specific riser, the division into corrosion protection zones is dependent on the particular riser or

platform design and the prevailing environmental conditions. The upper and lower limits of the ‘splash zone’ may be determined according to the definitions in Sec.1.

602 Adverse corrosive conditions occur in the zone above lowest astronomical tide (LAT) where the riser is intermittently wetted by waves, tide and sea spray (‘splash zone’). Particularly severe corrosive conditions apply to risers heated by an internal fluid. In the splash zone, the riser coating may be exposed to mechanical damage by surface vessels and marine operations, whilst there is limited accessibility for inspection and maintenance.

603 The riser section in the ‘atmospheric zone’ (i.e. above the splash zone) is more shielded from both severe weathering and mechanical damage. Furthermore, there is better accessibility for inspection and maintenance.

604 In the ‘submerged zone’ and in the splash zone below the lowest astronomical tide (LAT), an adequately designed CP system is capable of preventing corrosion at any damaged areas of the riser coating. In the tidal zone, a CP system will be marginally effective.

605 Different coating systems may be applied in the three corrosion protection zones defined above, provided they are compatible. The considerations according to a), b), c), f), g) and h) in D403 above apply for all of the three zones. Fastening devices for risers should be selected to be compatible with a specific riser coating rather than vice versa.

606 The following additional considerations affecting selection of coating system apply in the splash and atmospheric zones:

- resistance to under-rusting at coating defects
- maintainability
- compatibility with inspection procedures for internal and/ or external corrosion
- compatibility with equipment/procedures for removal of biofouling (if applicable)
- fire protection (if required).

607 External cladding with certain Cu-base alloys may be used for combined corrosion protection and anti-fouling, primarily in the transition of the splash zone and the submerged zone (see D602). However, metallic materials with anti-fouling properties must be electrically insulated from the CP system to be effective. Multiple-layer paint coatings and thermally sprayed aluminium coatings are applicable to the atmospheric and submerged zones, and in the splash zone if functional requirements and local conditions permit.

608 Mechanical and physical coating properties listed in D403 are also relevant for riser coatings, dependent on the particular corrosion protection zone. The applicable requirements to properties for each coating system and for quality control shall be defined in a purchase specification. Recommended practice for general requirements and quality control is given in DNV-RP-F106. Some of the coating systems with functional requirements defined in coating data sheets are applicable also as riser coatings.

609 In the submerged zone, the considerations for selection of coating in D403 apply. In addition, resistance to biofouling is relevant in surface waters of the submerged zone and the lowermost section of the splash zone may have to be considered.

610 Riser FJCs shall have properties matching the selected pipe coating. In the splash zone, field joint coatings should be avoided unless it can be demonstrated that their corrosion protection properties are closely equivalent to those of the adjacent coating.

D 700 Internal corrosion control (informative)

701 Options for internal corrosion control should be evaluated aiming for the most cost-effective solution meeting the overall requirements of safety and environmental regulations. The selection of the most cost-effective strategy for corrosion control requires that all major costs associated with operation of the pipeline system, as well as investment costs for corrosion control, are evaluated (“Life Cycle Cost Analysis”). When fluid corrosivity and efficiency of corrosion mitigation cannot be assessed with any high degree of accuracy, a “risk cost” may be added for a specific option being evaluated. The risk cost is the product of estimated probability and consequences (expressed in monetary units) of a particular failure mode (e.g. rupture or pinhole leakage) due to malfunction of the corrosion control system being considered (e.g. inhibitor addition to a potentially corrosive fluid). The probability of such failures should reflect the designer's confidence in estimating the fluid corrosivity and the efficiency of options for corrosion control being evaluated. Depending on the failure mode, consequences of failure may include costs associated with increased maintenance, repairs, lost capacity and secondary damage to life, environment and other investments.

702 The selection of a system for internal corrosion protection of pipelines and risers has a major effect on detailed design and must therefore be evaluated during conceptual design. The following options for corrosion control may be considered:

- a) processing of fluid for removal of liquid water and/or corrosive agents.
- b) use of linepipe or internal (metallic) lining/cladding with intrinsic corrosion resistance (see B300).
- c) use of organic corrosion protective coatings or linings (normally in combination with a) or d)).

d) chemical treatment, i.e. addition of chemicals with corrosion mitigating function.

In addition, the benefits of a corrosion allowance (see D200) should be duly considered for a) and d).

703 Corrosion control by fluid processing may involve removal of water from gas/oil (dehydration), or of oxygen from seawater for injection (deoxygenation), for example. Consequences of operational upsets on material degradation should be taken into account. The necessity for corrosion allowance and redundant systems for fluid processing should be considered. On-line monitoring of fluid corrosion properties downstream of processing unit is normally required. For oil export pipelines carrying residual amounts of water, a biocide treatment should be considered as a back up for prevention of bacterial corrosion. Periodic pigging for removal of water and deposits counteracts internal corrosion in general and bacterial corrosion in particular.

704 If internal coatings or linings are to be evaluated as an option for corrosion control, the following main parameters shall be considered:

- chemical compatibility with all fluids to be conveyed or contacted during installation, commissioning and operation, including the effects of any additives for control of flow or internal corrosion (see D706)
- resistance to erosion by fluid and mechanical damage by pigging operations
- resistance to rapid decompression
- reliability of quality control during coating application
- reliability of (internal) field joint coating systems, if applicable
- consequences of failure and redundant techniques for corrosion mitigation.

705 Internal coating of pipelines (e.g. by thin film of epoxy) has primarily been applied for the purpose of friction reduction in dry gas pipelines (“flow coatings” or “anti-friction coatings”). Any such coatings should have a minimum specified thickness of 40 μm and should comply with the minimum requirements in API RP 5L2. Although such coatings can not be expected to be efficient in preventing corrosion attack if corrosive fluids are conveyed, any coating with adequate properties may still be beneficial in reducing forms of attack affecting membrane stresses and hence, the pressure retaining capacity of the pipeline.

706 Chemical treatment of fluids for corrosion control may include:

- corrosion inhibitors (e.g. “film forming”)
- pH-buffering chemicals
- biocides (for mitigation of bacterial corrosion)
- glycol or methanol (added at high concentrations for hydrate inhibition, diluting the water phase)
- dispersants (for emulsification of water in oil)
- scavengers (for removal of corrosive constituents at low concentrations).

707 The reliability of chemical treatment should be evaluated in detail during the conceptual design. Important parameters to be considered are:

- anticipated corrosion mitigating efficiency for the actual fluid to be treated, including possible effects of scales, deposits, etc. associated with this fluid
- capability of the conveyed fluid to distribute inhibitor in the pipeline system along its full length and circumference
- compatibility with all pipeline system and downstream materials, particularly elastomers and organic coatings
- compatibility with any other additives to be injected,
- health hazards and environmental compatibility
- provisions for injection and techniques/procedures for monitoring of inhibitor efficiency
- consequences of failure to achieve adequate protection, and redundant techniques.

For pipelines carrying untreated well fluid or other fluids with high corrosivity and with high requirements to safety and reliability, there is a need to verify the efficiency of chemical treatment by integrity monitoring using a tool allowing wall thickness measurements along the full length of the pipeline (see Sec.12). Corrosion probes and monitored spools are primarily for detection of changes in fluid corrosivity and are not applicable for verification of the integrity of the pipeline.

708 The design of corrosion control based on fluid processing and/or chemical treatments should be reviewed by operator’s operational organisation.

SECTION 7 CONSTRUCTION – LINEPIPE

A. General

A 100 Objective

101 This section specifies the requirements for manufacture, testing and documentation of linepipe. All mechanical properties and dimensional tolerances shall be met after heat treatment, expansion or impansion, and final shaping.

102 Materials selection shall be performed in accordance with Sec.6.

103 This section does not cover any activities taking part after the pipes have been dispatched from the pipe mill, e.g. coating and girth welding.

104 The requirements stated herein for Carbon-Manganese (C-Mn) steel linepipe conform in general to ISO 3183 Annex J: “PSL 2 pipe ordered for offshore service”, with some additional and modified requirements.

105 Manufacturers of linepipe shall have an implemented quality assurance system according to ISO 9001.

A 200 Application

201 The requirements are applicable for linepipe made of:

- C-Mn steel
- clad or lined steel
- corrosion resistant alloys (CRA) including ferritic - austenitic (duplex) stainless steels, austenitic stainless steels, martensitic stainless steels (13Cr), other stainless steels and nickel based alloys.

Guidance note:

The principles from this standard may be applied for other materials, e.g. 9Ni steel. In such cases, specific material requirements must be defined in the project specification.

---e-n-d---of---G-u-i-d-a-n-c-e---n-o-t-e---

202 Materials, manufacturing methods and procedures that comply with recognised practices or proprietary specifications will normally be acceptable provided they comply with the requirements of this section.

A 300 Systematic review

301 The overall requirements to systematic review in Sec.2 will apply for the linepipe manufacturers to review this section and evaluate if the requirements in the purchase order and this standard can be met.

A 400 Process of manufacture

401 C-Mn linepipe shall be manufactured according to one of the following processes:

Seamless (SMLS)

Pipe manufactured by a hot forming process without welding. In order to obtain the required dimensions, the hot forming may be followed by sizing or cold finishing.

High Frequency Welded (HFW)

Pipe formed from strip and welded with one longitudinal seam formed by electric-resistance welding applied by induction or conduction with a welding current frequency ≥ 70 kHz, without the use of filler metal. The forming may be followed by cold expansion or reduction.

Submerged Arc-Welded (SAW)

Pipe manufactured by forming from strip or plate and with one longitudinal (SAWL) or helical (SAWH) seam formed by the submerged arc process, with at least one pass made on the inside and one pass from the outside of the pipe. The forming may be followed by cold expansion or reduction.

402 CRA linepipe may, in addition to SMLS and SAWL, be manufactured according to one of the following processes:

Electron Beam Welded (EBW) and Laser Beam Welded (LBW)

Pipe formed from strip and welded with one longitudinal seam, with or without the use of filler metal. The forming may be followed by cold expansion or reduction to obtain the required dimensional tolerances. These welding processes shall be subject to pre-qualification testing according to Appendix C.

Multiple welding processes (MWP)

Pipe formed from strip or plate and longitudinally welded using a combination of two or more welding processes (MWPL). If the combination of welding processes has not been used previously, pre-qualification

testing should be conducted according to Appendix C.

403 The backing steel of lined linepipe shall comply with A401.

404 The liner pipe of lined linepipe shall be manufactured in accordance with API 5LC.

405 Clad linepipe shall be manufactured from CRA clad C-Mn steel plate by application of a single longitudinal weld. With respect to the backing steel, the pipe manufacturing shall be in general compliance with one of the manufacturing routes for SAW pipe as given in Table 7-1. The longitudinal weld shall be MWP (see A402).

A 500 Supplementary requirements

501 When requested by the Purchaser and stated in the materials specification (as required in A600), linepipe to this standard shall meet supplementary requirements given in Subsection I, for:

- H₂S service (also referred to as sour service), suffix S (see I100)
- fracture arrest properties, suffix F (see I200)
- linepipe for plastic deformation, suffix P (see I300)
- enhanced dimensional requirements for linepipe, suffix D (see I400)
- high utilisation, suffix U (see I500).

A 600 Linepipe specification

601 A linepipe specification reflecting the results of the materials selection (see Sec.6 C200), referring to this section (Sec.7) of the offshore standard, shall be prepared by the Purchaser. The specification shall state any additional requirements to and/or deviations from this standard related to materials, manufacture, fabrication and testing of linepipe.

A 700 Manufacturing procedure specification

701 Prior to start of production, the Manufacturer shall prepare a Manufacturing Procedure Specification (MPS). The MPS shall demonstrate how the specified properties may be achieved and verified throughout the proposed manufacturing route.

The MPS shall address all factors that influence the quality and consistency of the product. All main manufacturing steps from control of received raw material to shipment of finished pipe, including all examination and check points, shall be outlined in detail.

References to the procedures established for the execution of all the individual production steps shall be included.

702 The MPS shall as a minimum contain the following information (as applicable):

- steel producer
- plan(s) and process flow description/diagram
- project specific quality control plan
- manufacturing process
- target chemical composition
- steel making and casting techniques
- ladle treatments (secondary refining), degassing, details of inclusion shape control, super heat
- method used to ensure that sufficient amount of intermixed zones between different orders are removed
- details and follow-up of limiting macro, as well as micro segregation, e.g. soft reduction and electro magnetic stirring (EMS) used during continuous casting
- manufacturer and manufacturing location of raw material and/or plate for welded pipes
- billets reheating temperature for seamless
- allowable variation in slab reheating temperature, and start and stop temperatures for finishing mill and accelerated cooling
- methods for controlling the hydrogen level (e.g. stacking of slabs and/or plates)
- pipe-forming procedure, including preparation of edges and control of alignment and shape (including width of strip for HFW)
- procedure for handling of welding consumable and flux
- all activities related to production and repair welding, including welding procedures and qualification
- heat treatment procedures (including in-line heat treatment of the weld seam) including allowable variation in process parameters
- method for cold expansion/reduction/sizing/finishing, target and maximum sizing ratio
- hydrostatic test procedures
- NDT procedures (also for strip/plate as applicable)
- list of specified mechanical and corrosion testing
- dimensional control procedures
- pipe number allocation
- pipe tracking procedure (traceability procedure)
- marking, coating and protection procedures
- handling, loading and shipping procedures.

A 800 Manufacturing procedure qualification test

801 The MPS shall be qualified for each nominal pipe diameter; either as part of first-day production or as a separate MPQT prior to full-scale production. For C-Mn steels with SMYS < 485 MPa that are not intended for H₂S service, relevant documentation may be agreed in lieu of qualification testing providing all essential variables in A807 are adhered to.

Guidance note:

Depending on the criticality of the project, it is recommended for all projects to carefully evaluate if the MPQT should be conducted prior to start of production.

It is not necessary to perform repeated qualification testing during one and the same project, even if the fabrication is interrupted by some weeks. This is provided that all procedures and equipment remain unchanged, and that all essential variables are adhered to.

---e-n-d---of---G-u-i-d-a-n-c-e---n-o-t-e---

802 For C-Mn steels with SMYS > 450 MPa, the qualification of the MPS should be completed prior to start of production.

803 Each MPQT shall include full qualification of one pipe from two different test units of different heats (a total of two pipes). If the entire production is limited to one heat, the MPQT may be performed on a single pipe from that heat. The minimum type and extent of chemical, mechanical, and non-destructive testing are given in this section. This includes all production tests plus additional tests given in Table 7-8, Table 7-13 and Table 7-15.

804 If the cold forming of C-Mn steel exceeds 5% strain after heat treatment, ageing tests shall be performed as part of the qualification testing. The tests shall be performed on the actual pipe without any straightening or additional deformation, see App.B B1101. The absorbed Charpy V-notch impact energy in the aged condition shall meet the requirements in Table 7-5.

805 Additional MPS qualification testing may be required by Purchaser (e.g. weldability testing, analysis for trace elements for steel made from scrap), as part of the qualification of the MPS (see A801). Weldability tests should be performed using the same welding equipment as used during installation or on the laybarge.

806 The validity of the MPQT shall be limited to the steelmaking, rolling, and manufacturing/ fabrication facilities used during the qualification.

807 In addition to the requirements stated above, the following changes (as applicable) to the manufacturing processes will require re-qualification of the MPS (essential variables):

- any change in steelmaking practice
- changes beyond the allowable variation for rolling practice, accelerated cooling and/or QT process
- change in nominal wall thickness exceeding + 5% to -10%
- change in ladle analysis for C-Mn steels outside $\pm 0.02\%$ C, ± 0.03 CE and/or ± 0.02 in Pcm
- any change in pipe forming process,
- any change in $s_r > \pm 0.0025$ (see B332 and B333)
- any change in alignment and joint design for welding
- change in welding heat input $\pm 15\%$.
- any change in welding wire type, thickness and configuration (including number of wires)
- any change in welding flux
- any change in shielding gas
- any change in make, type and model of welding equipment.

The following additional essential variable applies to HFW, EBW and LBW pipe:

- any change in nominal thickness
- change in welding heat coefficient
 $Q = (\text{amps} \times \text{volts}) / (\text{travel speed} \times \text{thickness}) \pm 5\%$
- addition or deletion of an impeder
- change in rollers position and strip width outside agreed tolerances.

In case issues only related to the welding process have been changed, the re-qualification of the MPS may be limited to the weld only (e.g. not base material testing).

808 If one or more tests in the MPQT fail, the MPS shall be reviewed and modified accordingly, and a complete re-qualification performed. Re-testing may be allowed subject to agreement. In the specific case of failed fusion line CVN tests (with reference to local brittle zones), retesting of further 2 sets removed from the failed MPQ pipe (at the same position relative to the wall thickness) is permitted prior to declaring the MPQT as having failed (see B510).

B. Carbon Manganese (C-Mn) Steel Linepipe

B 100 General

101 C-Mn steel linepipe fabricated according to this standard generally conform to the requirements in ISO 3183 Annex J: “PSL 2 pipe ordered for offshore service”. Any additional or modified requirements to ISO 3183 Annex J are highlighted in this subsection (B) as described in B102 and B103.

Additional or modified requirements

102 Paragraphs with additional requirements to ISO 3183 are marked at the end of the relevant paragraph with AR.

Paragraphs with modified requirements compared to ISO 3183 are marked at the end of the relevant paragraph with MR.

103 Additional or modified requirements when given in tables are marked in accordance with B102 with AR and MR in the relevant table cells.

B 200 Pipe designation

201 C-Mn steel linepipe shall be designated with:

- DNV
- process of manufacture
- SMYS
- supplementary requirement suffix (see Subsection I), as applicable. MR

Guidance note:

E.g. “DNV SMLS 450 SP” designates a seamless pipe with SMYS 450 MPa, meeting the supplementary requirements for H₂S service and plastic deformation (e.g. reeling installation) properties.

---e-n-d---of---G-u-i-d-a-n-c-e---n-o-t-e---

B 300 Manufacturing

Starting material and steel making

301 C-Mn steel linepipe shall be manufactured in accordance with the processes given in A400 using the starting materials and corresponding forming methods and final heat treatment as given in Table 7-1.

302 All manufacturing including steel making and the raw materials used shall be in accordance with the qualified MPS, follow the same activity sequence, and stay within the agreed allowable variations.

303 All steels shall be made by an electric or one of the basic oxygen processes. C-Mn steel shall be fully killed and made to a fine grain practice.

General requirements to manufacture of seamless pipe

304 SMLS pipe shall be manufactured from continuously (strand) cast or ingot steel.

305 If the process of cold finishing is used, this shall be stated in the inspection document.

306 Pipe ends shall be cut back sufficiently after rolling to ensure freedom from defects. AR

General requirements to manufacture of welded pipe

307 Strip and plate used for the manufacture of welded pipe should be rolled from continuously (strand) cast or pressure cast slabs. Strip or plate shall not contain any repair welds.

308 The strip width for spiral welded pipes should not be less than 0.8 and not more than 3.0 times the pipe diameter. Strip and plate shall be inspected visually after rolling, either of the plate, of the uncoiled strip or of the coil edges.

309 If agreed, strip and plate shall be inspected ultrasonically for laminar imperfections or mechanical damage, either before or after cutting the strip or plate, or the completed pipe shall be subjected to full-body inspection, including ultrasonic inspection, see Table 7-16.

310 Plate or strip shall be cut to the required width and the weld bevel prepared by milling or other agreed methods before forming. AR

311 Cold forming (i.e. below 250°C) of C-Mn steel shall not introduce a plastic deformation exceeding 5%, unless heat treatment is performed or ageing tests show acceptable results (see A804). AR

312 Normalising forming of materials and weldments shall be performed as recommended by the Manufacturers of the plate/strip and welding consumables. AR

313 Welding personnel for execution of all welding operations shall be qualified by in-house training. The in-house training program shall be available for review on request by Purchaser. AR

314 Welding and repair welding procedures for the seam weld shall be qualified as part of MPQT. AR

315 The following types of repair welding procedure shall, as a minimum, be qualified:

- Arc stop/restart
- Shallow repair (single pass is not allowed, a minimum of 2 passes)
- Deep repair (minimum 10% of WT, but not covering through thickness repair). The depth of the groove should be set by the Manufacturer.

Other repair procedures may be qualified, if agreed. Repair welding shall be qualified in a manner realistically simulating the repair situation to be qualified. AR

316 Welds containing defects may be locally repaired by welding, after complete removal of all defects. AR

317 The manufacturer shall ensure stable temperature conditions during welding. A minimum pre-welding temperature shall be established. If SAW seam welding is done in more than one pass per side, then a maximum interpass temperature shall be qualified. AR

318 Low hydrogen welding consumables shall be used and shall give a diffusible hydrogen content of maximum 5 ml/100 g weld metal. AR

319 Welding consumables shall be individually marked and supplied with an inspection certificate according to EN 10204 or an equivalent material certification scheme. Welding wire shall be supplied with certificate type 3.1, while certificate type 2.2 is sufficient for SAW Flux. AR

320 Handling of welding consumables and the execution and quality assurance of welding shall meet the requirements of in-house quality procedures. AR

SAW pipe

321 Any lubricant and contamination on the weld bevel or the surrounding areas shall be removed before making the seam welds of SAWL pipes or SAWH pipes.

322 Tack welds shall be made by: manual or semi-automatic submerged-arc welding, electric welding, gas metal-arc welding, gas tungsten-arc welding, flux-cored arc welding; or shielded metal-arc welding using a low hydrogen electrode. Tack welds shall be melted and coalesced into the final weld seam or removed by machining.

323 Intermittent tack welding of the SAWL groove shall not be used unless Purchaser has approved data furnished by Manufacturer to demonstrate that all mechanical properties specified for the pipe are obtainable at both the tack weld and intermediate positions.

324 Unless comparative tests results of diffusible hydrogen versus flux moisture content are provided (meeting the requirement in B318), the maximum residual moisture content of agglomerated flux shall be 0.03%.

Repair welding of all welded pipes

325 General requirements to repair welding:

- Any repair welding shall be carried out prior to cold expansion and final heat treatment.
- Repeated repairs shall be subject to agreement.
- Repair welding of cracks is not permitted.
- A local weld repair shall be at least 50 mm long or 4 times the repair depth, whichever is longer.
- The excavated portion of the weld shall be large enough to ensure complete removal of the defect, and the ends and sides of the excavation shall have a gradual taper from the bottom of the excavation to the surface. If air-arc gouging is used, the last 3 mm shall be removed by mechanical means to remove any carbon enriched zones. Removal of less than 3 mm may be accepted if it can be documented that the carbon enriched zones has been satisfactorily removed.
- Weld repairs shall be ground to merge smoothly into the original weld contour.

326 Qualification testing of repair welds shall be described in the MPS. It shall be documented that the repair weld metal, including all transition zones (e.g. interface between new and old weld metal along and at the end of repairs) meets the same requirements as the original weld metal and HAZ. AR

Guidance note:

It is recommended to review the test and qualification regime described in DNV-OS-F101, Appendix C Table C-4.

---e-n-d---of---G-u-i-d-a-n-c-e---n-o-t-e---

HFW pipe

327 The abutting edges of the strip or plate should be milled or machined immediately before welding. The weld flash shall be removed on both external and internal surface as required in Appendix D, Table D-4.

328 The width of the strip or plate should be continuously monitored. AR

329 The weld seam and the HAZ shall be fully normalized subsequent to welding. MR

Heat treatment

330 Heat treatments of SMLS and welded pipe shall be performed according to documented procedures used during MPQT.

331 The documented procedures shall be in accordance with any recommendations from the material Manufacturer with regard to heating and cooling rates, soaking time, and soaking temperature. AR

Cold expansion and cold sizing

332 The extent of cold sizing and cold forming expressed as the sizing ratio s_r , shall be calculated according to the following formula:

$$s_r = |D_a - D_b| / D_b$$

where

D_a is the actual outside diameter after sizing
 D_b is the actual outside diameter before sizing.

The actual outside diameter should be measured with a tape measure (i.e. perimeter as an average of all possible diameters). The sizing ratio should be checked every shift, preferably at both ends of the pipe. MR

333 The sizing ratio of cold expanded pipe should be within the range $0.003 < s_r \leq 0.015$. Expansion shall not introduce high local deformations.

334 Pipes may be cold sized to their final dimensions by expansion or reduction. This shall not produce excessive permanent strain. The sizing ratio, s_r , shall not exceed 0.015 if no subsequent heat treatment or only heat treatment of the weld area is performed.

335 The sizing ratio, s_r , for cold sizing of pipe ends shall not exceed 0.015 unless the entire pipe ends are subsequently stress relieved.

Finish of pipe ends

336 Pipe ends should be cut square and be free from burrs. MR

337 The internal weld bead shall be ground to a height of 0 to 0.5 mm for a distance of at least 100 mm at both pipe ends. The transition to the base material/pipe body shall be smooth without a noticeable step. This requirement is not applicable to HFW pipes.

Table 7-1 C-Mn steels, acceptable manufacturing routes				
<i>Type of pipe</i>	<i>Starting Material</i>	<i>Pipe forming</i>	<i>Final heat treatment</i>	<i>Delivery condition ¹⁾</i>
SMLS	Ingot, bloom or billet	Normalising forming	None	N
		Hot forming	Normalising or QT ²⁾	N or Q
		Hot forming and cold finishing		N or Q
HFW	Normalising rolled strip	Cold forming	Normalising of weld area	N
	Thermo-mechanical rolled strip		Heat treating of weld area	M
			Heat treating of weld area and stress relieving of entire pipe	M
	Hot rolled or normalising rolled strip	Cold forming	Normalising of entire pipe	N
			QT ²⁾ of entire pipe	Q
		Cold forming and hot reduction under controlled temperature, resulting in a normalised condition	None	N
Cold forming followed by thermomechanical forming of pipe	M			
SAW	Normalised or normalising rolled plate or strip	Cold forming	None, unless required due to degree of cold forming	N
	Thermo-mechanical rolled plate or strip			M
	QT ²⁾ plate or strip			Q
	As-rolled, QT ²⁾ , normalised or normalising rolled plate or strip	Normalising forming	None	N
		Cold forming	Normalising	N
		QT ²⁾	Q	
<i>Notes</i>				
1) The delivery conditions are: "Normalised" denoted N, "Quenched and Tempered", denoted Q, and "Thermomechanical rolled or formed", denoted M.				
2) Quenched and Tempered.				

338 The outside weld bead shall be ground to a height of maximum 0.5 mm for a distance of at least 250 mm at both pipe ends. The transition to the base material/pipe body shall be smooth and without a noticeable step. MR

339 If agreed, internal machining or grinding may be carried out. In case of machining, the following requirements shall be adhered to:

- if required in the purchase order the internal taper shall be located at a defined minimum distance from future bevel to facilitate UT or AUT
- the angle of the internal taper, measured from the longitudinal axis shall not exceed 7.0° for welded pipe. For SMLS pipe the maximum angle of the internal taper shall be as given in Table 7-2. MR

<i>Wall thickness t [mm]</i>	<i>Max. angle of taper [°]</i>
< 10.5	7.0
10.5 ≤ t < 14.0	9.5
14.0 ≤ t < 17.0	11.0
≥ 17.0	14.0

Jointers and strip end welds

340 Jointers should not be used.

341 If used, the jointer circumferential weld shall be qualified according to the requirements for pipeline girth welds given in Appendix C. Production testing requirements for jointers shall be in accordance with ISO 3183. Other manufacturing requirements shall comply with Annex A of ISO 3183.

342 Apart from linepipe supplied as coiled tubing, strip / plate end welds should not be permitted. MR

343 If used, see B341, strip / plate end welds shall comply with all applicable requirements in ISO 3183.

Re-processing

344 In case any mechanical tests fail during production of pipe from delivery condition N or Q, it is acceptable to conduct one re-heat treatment cycle of the entire test unit. All mechanical testing shall be repeated after re-heat treatment. No re-processing is allowed of delivery condition M material unless otherwise agreed. AR

Traceability

345 A system for traceability of the heat number, heat treatment batch and test unit number and the records from all required tests to each individual pipe shall be established and described in the MPS (see A702). Required repairs and records of dimensional testing and all other required inspections shall be included. Care shall be exercised during storage and handling to preserve the identification of materials. MR

B 400 Acceptance criteria

Chemical composition

401 The chemical compositions given in Table 7-3 are applicable to pipes with delivery condition N or Q (normalised or quenched and tempered according to Table 7-1), with nominal wall thickness $t \leq 25$ mm.

402 The chemical compositions given in Table 7-4 are applicable to pipes with delivery condition M (thermomechanical formed or rolled according to Table 7-1), with nominal thickness $t \leq 35$ mm. MR

403 For pipes with nominal wall thickness larger than the limits indicated in B401 and B402, the chemical composition shall be subject to agreement.

404 For pipe with a carbon content $\leq 0.12\%$ (product analysis), carbon equivalents shall be determined using the P_{cm} formula as given in Table 7-3 and Table 7-4. If the heat analysis for boron is less than 0.0005%, then it is not necessary for the product analysis to include boron, and the boron content may be considered to be zero for the P_{cm} calculation.

405 For pipe with a carbon content $> 0.12\%$ (product analysis) carbon equivalents shall be determined using the CE formula as given in Table 7-3.

Tensile properties

406 The tensile properties shall be as given in Table 7-5.

Guidance note 1:

The elongation requirements in Table 7-5 are based on a formula identical in API 5L, ISO 3183 and DNV-OS-F101. The formula is calibrated for use with tensile test specimens prepared according to ASTM A370 (i.e. API test specimens). It should be noted that the same material tested with specimens based on ASTM A370 and ISO 6892 can give different elongation results due to the different specimen geometries.

In general it should be considered to use ASTM A370 specimens for normal tensile testing, since this would give the best correspondence with the requirements in Table 7-5.

Tensile specimens based on ISO 6892 can be used, but then the acceptance criteria should be reviewed. Some options are; (i) use the values from Table 7-5, (ii) during qualification perform a number of tests on both types of specimens to establish an empirical correspondence for the specific material or (iii) define elongation criteria based on relevant testing experience and existing documentation.

---e-n-d---of---G-u-i-d-a-n-c-e---n-o-t-e---

Guidance note 2:

There is increasing interest among operators and installation contractors for digital/electronic version of the stress-strain curves. The advantage of digitally stored tensile test data is the ease of further analysis and use in calculations – both statistical for a production run and also in load/strain simulations.

Manufacturers should make preparations in case a project-specific requirement is included in a contract or specification. As a minimum all tensile tests during qualification should be stored and transmitted electronically.

---e-n-d---of---G-u-i-d-a-n-c-e---n-o-t-e---

407 For transverse weld tensile testing, the ultimate tensile strength shall be at least equal to the SMTS.

Hardness

408 The hardness in the Base Material (BM), Weld Metal (WM) and the Heat Affected Zone (HAZ) shall comply with Table 7-5. AR

CVN impact test

409 Requirements for Charpy V-notch impact properties for linepipe BM, WM and HAZ are given in Table 7-5. These values shall be met when tested at the temperatures given in Table 7-6. MR

410 Testing of Charpy V-notch impact properties shall, in general, be performed on test specimens 10 × 10 mm. Where test pieces of width < 10 mm are used, the measured average impact energy (KV_m) and the test piece cross-section measured under the notch (A) (mm²) shall be reported. For comparison with the values in Table 7-5, the measured energy shall be converted to the impact energy (KV) in Joules using the formula:

$$KV = \frac{8 \times 10 \times KV_m}{A} \quad (7.1)$$

AR

411 From the set of three Charpy V-notch impact specimens, only one is allowed to be below the specified average value and shall meet the minimum single value requirement. AR

Flattening test

412 For HFW pipe with SMYS ≥ 415 MPa and wall thickness ≥ 12.7 mm, there shall be no opening of the weld before the distance between the plates is less than 66% of the original outside diameter. For all other combinations of pipe grade and specified wall thickness, there shall be no opening of the weld before the distance between the plates is less than 50% of the original outside diameter.

413 For HFW pipe with a D/t₂ > 10, there shall be no cracks or breaks other than in the weld before the distance between the plates is less than 33% of the original outside diameter.

Guidance note:

The weld extends to a distance, on each side of the weld line, of 6.4 mm for D < 60.3 mm, and 13 mm for D ≥ 60.3 mm.

---e-n-d---of---G-u-i-d-a-n-c-e---n-o-t-e---

Guided-bend test

414 The guided-bend test pieces shall not:

- fracture completely
- reveal any cracks or ruptures in the weld metal longer than 3.2 mm, regardless of depth, or
- reveal any cracks or ruptures in the parent metal, HAZ, or fusion line longer than 3.2 mm or deeper than 12.5% of the specified wall thickness.

However, cracks that occur at the edges of the test piece during testing shall not be cause for rejection, provided that they are not longer than 6.4 mm.

Table 7-3 Chemical composition for C-Mn steel pipe with delivery condition N or Q, applicable for seamless and welded pipe.

SMYS	Product analysis, maximum. wt.%									Carbon equivalents	
	C ¹⁾	Si	Mn ¹⁾	P	S	V	Nb	Ti	Other ²⁾	CE ³⁾	P _{cm} ⁴⁾
Pipe with delivery condition N (normalised according to Table 7-1)											
245	0.14	0.40	1.35	0.020	0.010	Note ⁵⁾	Note ⁵⁾	0.04	Notes ^{6,7)}	0.36	0.19 ⁸⁾
290	0.14	0.40	1.35	0.020	0.010	0.05	0.05	0.04	Note ⁷⁾	0.36	0.19 ⁸⁾
320	0.14	0.40	1.40	0.020	0.010	0.07	0.05	0.04	Notes ^{6,7)}	0.38	0.20 ⁸⁾
360	0.16	0.45	1.65	0.020	0.010	0.10	0.05	0.04	Notes ⁶⁾	0.43	0.22 ⁸⁾
Pipe with delivery condition Q (quenched and tempered according to Table 7-1)											
245	0.14	0.40	1.35	0.020	0.010	0.04	0.04	0.04	Note ⁷⁾	0.34	0.19 ⁸⁾
290	0.14	0.40	1.35	0.020	0.010	0.04	0.04	0.04	Note ⁷⁾	0.34	0.19 ⁸⁾
320	0.15	0.45	1.40	0.020	0.010	0.05	0.05	0.04	Note ⁷⁾	0.36	0.20 ⁸⁾
360	0.16	0.45	1.65	0.020	0.010	0.07	0.05	0.04	Notes ^{6,9)}	0.39	0.20 ⁸⁾
390	0.16	0.45	1.65	0.020	0.010	0.07	0.05	0.04	Notes ^{6,9)}	0.40	0.21 ⁸⁾
415	0.16	0.45	1.65	0.020	0.010	0.08	0.05	0.04	Notes ^{6,9)}	0.41	0.22 ⁸⁾
450	0.16	0.45	1.65	0.020	0.010	0.09	0.05	0.06	Notes ^{6,9)}	0.42	0.22 ⁸⁾
485	0.17	0.45	1.75	0.020	0.010	0.10	0.05	0.06	Notes ^{6,9)}	0.42	0.23 ⁸⁾
555	0.17	0.45	1.85	0.020	0.010	0.10	0.06	0.06	Notes ^{6,9)}	As agreed	

Notes

- 1) For each reduction of 0.01% below the specified maximum for carbon, an increase of 0.05% above the specified maximum for manganese is permissible, up to a maximum increase of 0.20%.
- 2) Al total ≤ 0.060%; N ≤ 0.012%; Al/N ≥ 2:1 (not applicable to titanium-killed steel or titanium-treated steel).
- 3) $CE = C + \frac{Mn}{6} + \frac{(Cr + Mo + V)}{5} + \frac{(Ni + Cu)}{15}$
- 4) $P_{cm} = C + \frac{Si}{30} + \frac{Mn}{20} + \frac{Cu}{20} + \frac{Ni}{60} + \frac{Cr}{20} + \frac{Mo}{15} + \frac{V}{10} + 5B$
- 5) The sum of the niobium and vanadium contents should be ≤ 0.06%.
- 6) The sum of the niobium, vanadium, and titanium contents shall be ≤ 0.15%.
- 7) Cu ≤ 0.35%; Ni ≤ 0.30%; Cr ≤ 0.30%; Mo ≤ 0.10%; B ≤ 0.0005%.
- 8) For SMLS pipe, the listed value is increased by 0.03, up to a maximum of 0.25.
- 9) Cu ≤ 0.50%; Ni ≤ 0.50%; Cr ≤ 0.50%; Mo ≤ 0.50%; B ≤ 0.0005%.

Table 7-4 Chemical composition for C-Mn steel pipe with delivery condition M (thermo-mechanical formed or rolled according to Table 7-1).

SMYS	Product analysis, maximum. wt.%									Carbon equivalent
	C ¹⁾	Si	Mn ¹⁾	P	S	V	Nb	Ti	Other ²⁾	P _{cm} ³⁾
245	0.12	0.40	1.25	0.020	0.010	0.04	0.04	0.04	Note ⁴⁾	0.19
290	0.12	0.40	1.35	0.020	0.010	0.04	0.04	0.04	Note ⁴⁾	0.19
320	0.12	0.45	1.35	0.020	0.010	0.05	0.05	0.04	Note ⁴⁾	0.20
360	0.12	0.45	1.65	0.020	0.010	0.05	0.05	0.04	Notes ^{5,6)}	0.20
390	0.12	0.45	1.65	0.020	0.010	0.06	0.08	0.04	Notes ^{5,6)}	0.21
415	0.12	0.45	1.65	0.020	0.010	0.08	0.08	0.06	Notes ^{5,6)}	0.21
450	0.12	0.45	1.65	0.020	0.010	0.10	0.08	0.06	Notes ^{5,6)}	0.22
485	0.12	0.45	1.75	0.020	0.010	0.10	0.08	0.06	Notes ^{5,6)}	0.22 ⁷⁾
555	0.12	0.45	1.85	0.020	0.010	0.10	0.08	0.06	Notes ^{5,6)}	0.24 ⁷⁾

Notes

- 1) For each reduction of 0.01% below the specified maximum for carbon, an increase of 0.05% above the specified maximum for manganese is permissible, up to a maximum increase of 0.20%.
- 2) Al total ≤ 0.060%; N ≤ 0.012%; Al/N ≥ 2:1 (not applicable to titanium-killed steel or titanium-treated steel).
- 3) $P_{cm} = C + \frac{Si}{30} + \frac{Mn}{20} + \frac{Cu}{20} + \frac{Ni}{60} + \frac{Cr}{20} + \frac{Mo}{15} + \frac{V}{10} + 5B$
- 4) Cu ≤ 0.35%; Ni ≤ 0.30%; Cr ≤ 0.30%; Mo ≤ 0.10%; B ≤ 0.0005%.
- 5) The sum of the niobium, vanadium, and titanium contents shall be ≤ 0.15%.
- 6) Cu ≤ 0.50%; Ni ≤ 0.50%; Cr ≤ 0.50%; Mo ≤ 0.50%; B ≤ 0.0005%.
- 7) For nominal wall thickness t > 25 mm the carbon equivalent may be increased with 0.01.

Table 7-5 C-Mn steel pipe, mechanical properties

	Yield strength $R_{10,5}$ [MPa]		Tensile strength R_m [MPa]		Ratio $R_{10,5}/R_m$	Elongation in 50.8 mm A_f [%]	Hardness [HV10]		Charpy V-notch energy (KVT) for BM, WM and HAZ ¹⁾ [J]	
	min.	max.	min. ²⁾	max.			max.	min.	max.	average
SMYS										
245	245	450 ³⁾	415	760	0.93	Note 4)	270	300	27	22
290	290	495	415	760			270		30	24
320	320	520	435	760			270		32	27
360	360	525	460	760			270		36	30
390	390	540	490	760			270		39	33
415	415	565	520	760			270		42	35
450	450	570	535	760			270		45	38
485	485	605	570	760			300		50	40
555	555	675	625	825			300		56	45

Notes

- 1) The required KVL (longitudinal direction specimens) values shall be 50% higher than the required KVT values.
- 2) If tested in the longitudinal direction, a minimum tensile strength 5% less than the required value is acceptable (does not apply to all weld tensile tests).
- 3) For pipe with specified outside diameter < 219.1 mm, the yield strength shall be ≤ 495 MPa.
- 4) The specified minimum elongation in 50.8 mm, A_f , expressed in percent, rounded to the nearest percent shall be as determined using the following equation:

$$A_f = C \frac{A_{xc}^{0,2}}{U^{0,9}}$$

where:

C is 1940 for calculations using SI units;

A_{XC} is the applicable tensile test piece cross-sectional area, as follows:

- for circular cross section test pieces, 130 mm² for 12.7 mm and 8.9 mm diameter test pieces; and 65 mm² for 6.4 mm test pieces
- for full-section test pieces, the lesser of a) 485 mm² and b) the cross-sectional area of the test piece, calculated using the specified outside diameter and the specified wall thickness of the pipe, rounded to the nearest 10 mm²
- for strip test pieces, the lesser of a) 485 mm² and b) the cross-sectional area of the test piece, calculated using the specified width of the test piece and the specified wall thickness of the pipe, rounded to the nearest 10 mm²

U is the specified minimum tensile strength, in MPa.

Table 7-6 C-Mn steel linepipe, Charpy V-notch impact testing temperatures T_0 (°C) as a function of T_{min} (°C) (Minimum Design Temperature)

Nominal wall Thickness (mm)	PIPELINES and risers
$t \leq 20$	$T_0 = T_{min}$
$20 < t \leq 40$	$T_0 = T_{min} - 10$
$t > 40$	$T_0 =$ to be agreed in each case

Fracture toughness of weld seam

415 The measured fracture toughness shall as a minimum have a CTOD value of 0.15 mm, when tested at the minimum design temperature. AR

Macro examination of weld seam

416 The macro section shall show a sound weld merging smoothly into the base material without weld defects according to App.D Table D-4. Complete re-melting of tack welds shall be demonstrated for double sided SAW pipes. MPQT welds shall meet the requirements of ISO 5817 Quality level C. AR

417 The misalignment of the axes of internal and external weld seams and the weld interpenetration of double sided SAW pipes shall be verified on the macro section and meet the requirements given in Appendix D, Table D-4.

Metallographic examination of HFW pipe

418 The metallographic examination shall be documented by micrographs at sufficient magnification and resolution to demonstrate that no detrimental oxides from the welding process are present along the weld line. AR

419 It shall be verified that the entire HAZ has been appropriately heat treated over the full wall thickness and that no untempered martensite remains.

Hydrostatic test

420 The pipe shall withstand the hydrostatic test without leakage through the weld seam or the pipe body.

421 Linepipe that fails the hydrostatic test shall be rejected. AR

422 For pipe classified as coiled tubing, the hydrostatic test of the finished coiled tubing shall be performed at a pressure corresponding to 100% of SMYS calculated in accordance with the Von Mises equation and considering 95% of the nominal wall thickness. Test pressure shall be held for not less than two hours. AR

Surface condition, imperfections and defects

423 Requirements to visual examination performed at the plate mill are given in App.D, Subsection G. Requirements for visual inspection of welds and pipe surfaces are given in App.D H500. MR and AR

Dimensions, mass and tolerances

424 Requirements to dimensions, mass and tolerances shall be as given in Subsection G.

Weldability

425 If agreed, the Manufacturer shall supply weldability data or perform weldability tests. The details for carrying out the tests and the acceptance criteria shall be as specified in the purchase order.

426 If requested, the linepipe supplier shall provide information regarding the maximum Post Weld Heat Treatment (PWHT) temperature for the respective materials. AR

B 500 Inspection

501 Compliance with the requirements of the purchase order shall be checked by specific inspection in accordance with EN 10204. Records from the qualification of the MPS and other documentation shall be in accordance with the requirements in Sec.12.

Inspection frequency

The inspection frequency during production shall be as given in Table 7-7 and the Frequency of testing for MPQT as given in Table 7-8. Reference to the relevant acceptance criteria is given in these tables. Pipes for testing should be evenly distributed, both throughout the production period and between welding stations. MR

Guidance note:

Pipes for production testing shall be representative of all pipes produced. This means that sample pipes should be taken from as many work shifts as possible (distributing the sampling throughout the production period), and sampling should be rotated between the different welding stations.

It is not acceptable practice to select one plate from a number of heats in order to concentrate the production of pipes for sampling.

---e-n-d---of---G-u-i-d-a-n-c-e---n-o-t-e---

502 A test unit is a prescribed quantity of pipe that is made to the same specified outside diameter and specified wall thickness, by the same pipe-manufacturing process, from the same heat, and under the same pipe-manufacturing conditions.

503 For coiled tubing, all required mechanical testing in Table 7-7 shall be performed at each pipe end or for each heat, whichever gives the highest number of tests. Strip end welds for coiled tubing shall be tested according to ISO 3183 Annex J. AR

504 Sampling for mechanical and any corrosion testing shall be performed after heat treatment, expansion and final shaping. The number and orientation of the samples for mechanical testing are given in Table 7-9. The samples shall not be prepared in a manner that may influence their mechanical properties.

505 In case of large quantities of longitudinally welded large diameter and heavy wall thickness pipe, where the test unit is governed by the heat size, it may be agreed that pipes from several heats represents one test unit. The first 30 000 tons shall be tested with a frequency according to normal practice of this standard. After exceeding 30 000 tons, the below testing philosophy may be applied:

- each test unit may consist of pipes from maximum 3 heats
- in case of test failure, the test frequency shall revert to the normal rate of testing until again 30 000 tons with satisfactory results are documented.

Re-testing

506 In order to accept or reject a test unit as a result of a test unit release failure, re-testing shall be conducted in accordance with B507 through B511.

507 If a test fails to meet the requirements, two re-tests shall be performed (for the failed test only) on samples taken from two different pipes within the same test unit. Both re-tests shall meet the specified requirements. The test unit shall be rejected if one or both of the re-tests do not meet the specified requirements.

508 The reason for the failure of any test shall be established and the appropriate corrective action to prevent re-occurrence of the test failures shall be taken accordingly.

509 If a test unit has been rejected, the Manufacturer may conduct individual testing of all the remaining pipes in the test unit. If the total rejection of all the pipes within one test unit exceeds 25%, the test unit shall be rejected. In this situation the Manufacturer shall investigate and report the reason for failure and shall change the manufacturing process if required. Re-qualification of the MPS is required if the agreed allowable variation of any parameter is exceeded (see A807 and A808).

510 Re-testing of failed pipes shall not be permitted. If a pipe fails due to low CVN values in the fusion line (HAZ) or weld line in HFW pipe, testing of samples from the same pipe may be performed subject to agreement. Refer to B344 for re-processing of pipe.

511 If the test results are influenced by improper sampling, machining, preparation, treatment or testing, the test sample shall be replaced by a correctly prepared sample from the same pipe and a new test performed.

Heat and product analysis

512 Heat and product analysis shall be performed in accordance with Appendix B. MR

513 If the value of any elements, or combination of elements, fails to meet the requirements, two re-tests shall be performed on samples taken from two different pipes from the same heat. If one or both re-tests fail to meet the requirements, the heat shall be rejected. MR

Mechanical testing

514 All mechanical testing shall be performed according to Appendix B. MR

Metallurgical testing

515 Macro examination and metallographic examination shall be performed in accordance with Appendix B.

Hydrostatic test (mill pressure test)

516 Hydrostatic testing shall be performed in accordance with Subsection E. MR

Non-destructive testing

517 NDT, including visual inspection, shall be carried out in accordance with Subsection F. AR and MR

Dimensional testing

518 Dimensional testing shall be performed according to Subsection G. MR

Treatment of surface imperfections and defects

519 Surface imperfections and defects shall be treated according to App.D H300. MR

Table 7-7 Inspection frequency for C-Mn steel linepipe during production^{1, 2)}			
<i>Applicable to:</i>	<i>Type of test</i>	<i>Frequency of testing</i>	<i>Acceptance criteria</i>
All pipe	Heat analysis	One analysis per heat	Table 7-3 or Table 7-4
	Product analysis	Two analyses per heat (taken from separate product items)	
	Tensile testing of the pipe body	Once per test unit of not more than 50/100 ³⁾ pipes with the same cold-expansion ratio	Table 7-5
	CVN impact testing of the pipe body of pipe with specified wall thickness as given in Table 22 of ISO 3183	Once per test unit of not more than 50/100 ⁵⁾ pipes with the same cold-expansion ratio	Table 7-5 and Table 7-6
	Hardness testing	Once per test unit of not more than 50/100 ³⁾ pipes with the same cold-expansion ratio (AR)	Table 7-5
	Hydrostatic testing	Each pipe	B420 to B422
	Pipe dimensional testing	See Subsection G	See Subsection G
	NDT including visual inspection	See Subsection F (MR and AR)	See Subsection F (MR and AR)

Table 7-7 Inspection frequency for C-Mn steel linepipe during production ^{1, 2)} (Continued)			
<i>Applicable to:</i>	<i>Type of test</i>	<i>Frequency of testing</i>	<i>Acceptance criteria</i>
SAWL, SAWH, HFW	Tensile testing of the seam weld (cross weld test)	Once per test unit of not more than 50/100 ⁵⁾ pipes with the same cold-expansion ratio (MR)	B406 and B407
	CVN impact testing of the seam weld of pipe with specified wall thickness as given in Table 22 of ISO 3183	Once per test unit of not more than 50/100 ⁴⁾ pipes with the same cold-expansion ratio (MR)	Table 7-5 and Table 7-6
	Hardness testing of hard spots	Any hard spot exceeding 50 mm in any direction	App.D H500
	Macrographic testing of seam weld	At least once per operating shift ⁶⁾	B416
SAWL, SAWH	Guided-bend testing of the seam weld of welded pipe	Once per test unit of not more than 50/100 ³⁾ pipes with the same cold-expansion ratio (MR)	B414 and B417
HFW	Flattening test	As shown in Figure 6 of ISO 3183	B412 and B413
	Metallographic examination	At least once per operating shift ⁶⁾	B418 and B419 (MR)
<i>Notes</i>			
1) Sampling of specimens and test execution shall be performed in accordance with Appendix B. For tensile, CVN, hardness, guided-bend and flattening testing Appendix B refers to ISO 3183 without additional requirements. 2) The number orientation and location of test pieces per sample for mechanical tests shall be in accordance with Table 7-9. 3) Not more than 100 pipes with $D \leq 508$ mm and not more than 50 pipes for $D > 508$ mm. 4) Not more than 100 pipes with $114.3 \text{ mm} \leq D \leq 508$ mm and not more than 50 pipes for $D > 508$ mm. 5) Not more than 100 pipes with $219.1 \text{ mm} \leq D \leq 508$ mm and not more than 50 pipes for $D > 508$ mm. 6) At least once per operating shift plus whenever any change of pipe size occurs during the operating shift. where D = Specified outside diameter			

Table 7-8 Additional testing for Manufacturing Procedure Qualification Test for C-Mn steel pipe ¹⁾			
<i>Applicable to:</i>	<i>Type of test</i>	<i>Frequency of testing</i>	<i>Acceptance criteria</i>
All pipe	All production tests as stated in Table 7-7	One test for each pipe provided for manufacturing procedure qualification ⁵⁾	See Table 7-7
	Base metal longitudinal tensile test ²⁾ , AR		
SMLS pipe ^{3, 4)} with $t > 25$ mm	CVN testing at ID of quenched and tempered seamless pipe with $t > 25$ mm AR		Table 7-5 and Table 7-6
Welded pipe (all types)	All-weld tensile test AR		Table 7-5 ⁹⁾
	Fracture toughness (CTOD) test of weld metal ^{6, 7)} AR		B415
	Ageing test ⁸⁾ , see A606 AR	Table 7-5	
<i>Notes</i>			
1) Sampling of specimens and test execution shall be performed in accordance with Appendix B. 2) Additional longitudinal test specimen is not necessary if already required by Table 7-7 and Table 7-9 for production testing. 3) Only applicable to pipe delivered in the quenched and tempered condition. 4) Sampling shall be 2 mm from the internal surface, see App.B B300. 5) One pipe from two different test units of different heats shall be selected for the MPQT, see A800 (a total of 2 pipes). 6) CTOD testing is not required for pipes with $t < 13$ mm. CTOD testing is not required of HAZ, only the centre of the weld. 7) For HFW pipe the testing applies to the fusion line (weld centre line). 8) Only when cold forming during pipe manufacture exceeds 5% strain. 9) Only SMYS, SMTS and elongation applies. where t = specified nominal wall thickness			

Table 7-9 Number, orientation, and location of test specimens per tested pipe ^{1, 2)}						
<i>Applicable to:</i>	<i>Sample location</i>	<i>Type of test</i>	<i>Wall thickness</i>			
			<i>≤ 25 mm</i>		<i>> 25 mm</i>	
			<i>Specified outside diameter</i>		<i>Specified outside diameter</i>	
			<i>< 219.1 mm</i>	<i>≥ 219.1 mm</i>	<i>< 219.1 mm</i>	<i>≥ 219.1 mm</i>
SMLS, not cold expanded pipe	Pipe body	Tensile	1L ³⁾	1L	1L ³⁾	1L
		CVN	3T	3T	3T	3T
		Hardness	1T	1T	1T	1T
SMLS, cold expanded pipe	Pipe body	Tensile	1L ³⁾	1T ⁴⁾	1L ³⁾	1T ⁴⁾
		CVN	3T	3T	3T	3T
		Hardness	1T	1T	1T	1T
HFW pipe	Pipe body	Tensile	1L90 ³⁾	1T180 ⁴⁾	1L90 ³⁾	1T180 ⁴⁾
		CVN	3T90	3T90	3T90	3T90
	Seam weld	Tensile	—	1W	—	1W
		CVN	3W and 3HAZ ⁵⁾	MR	6W and 6HAZ ⁵⁾	MR
		Hardness	1W	1W	1W	1W
	Pipe body and weld	Flattening	As shown in Figure 6 of ISO 3183			
SAWL pipe	Pipe body	Tensile	1L90 ³⁾	1T180 ⁴⁾	1L90 ³⁾	1T180 ⁴⁾
		CVN	3T90	3T90	3T90	3T90
	Seam weld	Tensile	—	1W	—	1W
		CVN	3W and 6HAZ ⁶⁾	MR	6W and 12HAZ ⁶⁾	MR
		Guided-bend	2W	2W	2W	2W
		Hardness	1W	1W	1W	1W
SAWH pipe	Pipe body	Tensile	1L ³⁾	1T ⁴⁾	1L ³⁾	1T ⁴⁾
		CVN	3T	3T	3T	3T
	Seam weld	Tensile	—	1W	—	1W
		CVN	3W and 6HAZ ⁶⁾	MR	6W and 12HAZ ⁶⁾	MR
		Guided-bend	2W	2W	2W	2W
		Hardness	1W	1W	1W	1W

Notes

- 1) See Figure 5 of ISO 3183 for explanation of symbols used to designate orientation and location.
- 2) All destructive tests may be sampled from pipe ends.
- 3) Full-section longitudinal test pieces may be used at the option of the manufacturer, see Appendix B.
- 4) If agreed, annular test pieces may be used for the determination of transverse yield strength by the hydraulic ring expansion test in accordance with ASTM A370.
- 5) For the HF weld seam, W means that the notch shall be located in the FL, while HAZ means that the notch shall be located in FL +2 (see Figure 6 in Appendix B).
- 6) HAZ means that the notch shall be located in FL and FL +2 (see Figure 5 in Appendix B).

C. Corrosion Resistant Alloy (CRA) Linepipe

C 100 General

101 All requirements of this subsection are applicable to welded and seamless linepipe in duplex stainless steel and seamless martensitic 13Cr stainless steel.

102 Austenitic stainless steel and nickel based CRA linepipe shall be supplied in accordance with a recognised standard that defines the chemical composition, mechanical properties, delivery condition and all the details listed in Sec.6 and as specified in the following. If a recognised standard is not available, a specification shall be prepared that defines these requirements.

C 200 Pipe designation

201 CRA linepipe to be used to this standard shall be designated with:

- DNV
- process of manufacture (see A400)
- grade (see Table 7-10 or C102, as applicable)
- supplementary requirement suffix (see A500).

Guidance note:

e.g. “DNV SMLS 22Cr D” designates a seamless 22Cr duplex steel linepipe meeting the supplementary requirements for enhanced dimensional requirements.

---e-n-d---of---G-u-i-d-a-n-c-e---n-o-t-e---

C 300 Manufacturing

Starting material and steel making

301 CRA linepipe shall be manufactured in accordance with the processes given in A402 using the raw materials stated in the qualified MPS, follow the same activity sequence, and stay within the agreed allowable variations. The manufacturing practice and instrumentation used to ensure proper control of the manufacturing process variables and their tolerances shall be described in the MPS.

302 All steels shall be made by an electric or one of the basic oxygen processes.

Requirements to manufacture of pipe

303 In addition to the requirements in C304 and C305 below, the following requirements given for C-Mn steel pipe are also applicable for CRA pipes:

- B304-306 for seamless pipe
- B307-310 and B313-320 for all welded pipes
- B321-326 for SAW and MWP pipe
- B330-345 for all pipe.

304 Before further processing, the slabs/ingots shall be inspected and fulfil the surface finish requirements specified in the MPS.

Supply conditions

305 Duplex and austenitic stainless steel pipe shall be delivered in solution-annealed and water-quenched condition.

C 400 Acceptance criteria

Chemical composition

401 The chemical composition of duplex stainless steel and martensitic 13Cr stainless steel parent materials shall be according to Table 7-10. Modifications are subject to agreement. The limits and tolerances for trace elements for martensitic 13Cr stainless steels, i.e. elements not listed in Table 7-10, shall be subject to agreement.

Mechanical properties

402 Requirements for tensile, hardness and Charpy V-notch properties are given in Table 7-11. Weldment shall meet the requirement for KVT impact properties. The Charpy V-notch specimens shall be tested at the temperatures given in Table 7-6.

403 In addition to the requirements in C404 and C405 below, the following acceptance criteria given for C-Mn steel pipe are also applicable to CRA pipe (as applicable):

- B407 for transverse weld tensile testing
- B410 and 411 for Charpy V-notch impact testing
- B414 for guided-bend testing
- B415 for fracture toughness testing of the seam weld.

404 For the flattening test of pipe with wall thickness ≥ 12.7 mm, there shall be no opening of the weld, including the HAZ, until the distance between the plates is less than 66% of the original outside diameter. For pipe with wall thickness < 12.7 mm there shall be no opening of the weld, including the HAZ, until the distance between the plates is less than 50% of the original outside diameter.

405 For pipe with a $D/t_2 > 10$, there shall be no cracks or breaks other than in the weld, including the HAZ, until the distance between the plates is less than 33% of the original outside diameter.

Macro examination of weld seam

406 The macro examination of weld seam shall meet the requirements in B416 and B417.

Microstructure of duplex stainless steel

407 The material shall be essentially free from grain boundary carbides, nitrides and intermetallic phases after solution heat treatment. Essentially free implies that occasional strings of detrimental phases along the centreline of the base material is acceptable given that the phase content within one field of vision (at 400X magnification) is $< 1.0\%$ (max. 0.5% intermetallic phases).

408 The base material ferrite content of duplex stainless steel shall be within the range 35-55%. For weld metal the ferrite content shall be within the range 30-65%.

Corrosion resistance of duplex stainless steel

409 The maximum allowable weight loss for 25Cr duplex stainless steel is 4.0 g/m² for solution annealed material tested for 24 hours at 50°C.

Table 7-10 Duplex- and martensitic stainless steel linepipe, chemical composition (Continued)

Element ¹⁾	Product analysis, wt.%			
	Grade 22Cr duplex	Grade 25Cr duplex	Grade 13Cr - 2 Mo	Grade 13Cr - 2.5 Mo
C	0.030 max	0.030 max	0.015 max	0.015 max
Mn	2.00 max	1.20 max	-	-
Si	1.00 max	1.00 max	-	-
P	0.030 max	0.035 max	0.025 max	0.025 max
S	0.020 max	0.020 max	0.003 max	0.003 max
Ni	4.50 - 6.50	6.00 - 8.00	4.50 min	6.00 min
Cr	21.0 - 23.0	24.0 - 26.0	12.0 min	12.0 min
Mo	2.50 - 3.50	3.00 - 4.00	2.00 min	2.50 min
N	0.14 - 0.20	0.20 - 0.34	-	-
PRE	-	min. 40 ²⁾	-	-

Notes

1) If other alloying elements than specified in this table are being used, the elements and the maximum content shall be agreed in each case.
 2) PRE = %Cr+3.3%Mo+16%N.

Table 7-11 Duplex and martensitic 13Cr stainless steel linepipe, mechanical properties

Grade	SMYS	SMTS	Ratio	Maximum Hardness (HV10)		Elongation in 50.8 mm A _f [%]	Charpy V-notch energy (KVT) for BM, WM and HAZ ¹⁾ [J]	
	MPa	MPa	R _{t0.5} / R _m	BM	WM HAZ		Mean	Single
22Cr	450	620	0.92	290	350	Note ²⁾	45	35
25Cr	550	750	0.92	330	350		55	45
13Cr-2 Mo and 13Cr-2.5 Mo	550	700	0.92	300	na		55	45

Notes

1) The required KVL (longitudinal direction specimens) values shall be 50% higher than the required KVT values.
 2) Ref. Note 4) in Table 7-5.

C 500 Inspection

501 Compliance with the requirements of the purchase order shall be checked by specific inspection in accordance with EN 10204, or an equivalent material inspection scheme. Records from the qualification of the MPS and other documentation shall be in accordance with the requirements in Sec.12.

Inspection frequency

502 The inspection frequency during production and MPQT shall be as given in Table 7-12 and Table 7-13, respectively. Reference to the relevant acceptance criteria is given in the tables.

503 A test unit is a prescribed quantity of pipe that is made to the same specified outside diameter and specified wall thickness, by the same pipe-manufacturing process, from the same heat, and under the same pipe-manufacturing conditions.

504 Sampling for mechanical and corrosion testing shall be performed after heat treatment, expansion and final shaping. The samples shall not be prepared in a manner that may influence their mechanical properties. Refer to B505 for reduced frequency of testing in case of large quantities of pipe.

505 The number and orientation of the samples for SMLS and SAWL/SAWH pipe shall be according to Table 7-9.

506 For EBW and LBW pipe, the number and orientation of the samples shall be as for HFW in Table 7-9.

507 For MWP pipe, the number and orientation of the samples shall be as for SAWL pipe in Table 7-9.

Retesting

508 Requirements for retesting shall be according to B507 to B511.

Heat and product analysis

509 Heat and product analysis shall be performed in accordance with Appendix B.

510 All elements listed in the relevant requirement/standard shall be determined and reported. Other elements added for controlling the material properties may be added, subject to agreement.

511 If the value of any elements, or combination of elements, fails to meet the requirements, two re-tests shall be performed on samples taken from two different pipes from the same heat. If one or both re-tests fail to meet the requirements, the heat shall be rejected.

Mechanical testing

512 All mechanical testing shall be performed according to Appendix B.

Metallographic examination

513 Metallographic examination shall be performed in accordance with Appendix B.

Corrosion testing of duplex stainless steels

514 Corrosion testing of 25Cr duplex stainless steels according to ASTM G48 shall be performed in accordance with App.B B200. ASTM G48 testing is not applicable for 22Cr duplex or other CRAs with PRE lower than 40.

Hydrostatic test (mill pressure test)

515 Hydrostatic testing shall be performed in accordance with Subsection E.

Non-destructive testing

516 NDT, including visual inspection, shall be in accordance with Subsection F.

Dimensional testing

517 Dimensional testing shall be performed according to Subsection G.

Treatment of surface imperfections and defects

518 Surface imperfections and defects shall be treated according to App.D H300.

<i>Applicable to</i>	<i>Type of test</i>	<i>Frequency of testing</i>	<i>Acceptance criteria</i>
All pipe	All tests in Table 7-7 applicable to “All pipe”	As given in Table 7-7	Table 7-10 and Table 7-11
SAWL and MWP pipe	All tests in Table 7-7 applicable to “SAWL”		
EBW and LBW pipe ²⁾	Flattening test	As shown in Figure 6 of ISO 3183	C404 and C405
Duplex stainless steel pipe	Metallographic examination	Once per test unit of not more than 50/100 ³⁾	C407 and C408
25Cr duplex stainless steel pipe	Pitting corrosion test (ASTM G48 Method A)	Once per test unit of not more than 50/100 ³⁾	C409
<i>Notes</i>			
1) Sampling of specimens and test execution shall be performed in accordance with Appendix B. The number orientation and location of test pieces per sample for mechanical tests shall be according to C505-507. 2) For EBW and LBW pipes the testing applies to the fusion line. 3) Not more than 100 pipes with $114.3 \text{ mm} \leq D \leq 508 \text{ mm}$ and not more than 50 pipes for $D > 508 \text{ mm}$. where D = Specified outside diameter			

<i>Applicable to</i>	<i>Type of test</i>	<i>Frequency of testing</i>	<i>Acceptance criteria</i>
All pipe	All production tests as stated in Table 7-12	One test for each pipe provided for manufacturing procedure qualification ³⁾	Subsection C
Welded pipe (all types)	All-weld tensile test		Table 7-11
	Fracture toughness (CTOD) test of weld metal ²⁾		B415
<i>Notes</i>			
1) Sampling of specimens and test execution shall be performed in accordance with Appendix B. The number, orientation and location of test pieces per sample for mechanical tests shall be according to C505-507. 2) CTOD testing is not required for pipes with $t < 13$ mm. 3) Two pipes shall be provided for MPQT. The two pipes provided shall be from two different test units of different heats.			

D. Clad or Lined Steel Linepipe

D 100 General

101 The requirements below are applicable to linepipe consisting of a C-Mn steel backing material with a thinner internal CRA layer.

102 The backing steel of lined pipe shall fulfil the requirements in Subsection B.

103 The manufacturing process for clad or lined linepipe shall be according to A403 to A405.

104 Cladding and liner materials shall be specified according to recognised standards. If a recognised standard is not available, a specification shall be prepared that defines chemical composition. If agreed corrosion testing and acceptance criteria shall be specified.

105 The cladding/liner material thickness should not be less than 2.5 mm.

D 200 Pipe designation

201 In addition to the designation of the backing material (see A403 to A405) clad/lined pipes shall be designated with:

- C, for clad pipe, or
- L, for lined pipe
- UNS number for the cladding material or liner pipe.

Guidance note:

e.g. “DNV MWPL 415 D C - UNS XXXXX” designates a longitudinal welded pipe using multiple welding processes with SMYS 415 MPa, meeting the supplementary requirements for dimensions, clad with a UNS designated material.

---e-n-d---of---G-u-i-d-a-n-c-e---n-o-t-e---

D 300 Manufacturing procedure specification

MPS for clad linepipe

301 In addition to the applicable information given in A700 and A800, the MPS for clad linepipe shall as a minimum contain the following information (as applicable):

- slab reheating temperature and initial rolling practice of cladding alloy and backing material prior to sandwich assembly
- method used to assemble the sandwich or one-sided-open package, as applicable, prior to reheating and rolling
- package (sandwich or one-side-open) reheating temperature, start and stop rolling temperatures, means of temperature and thickness control, start and stop temperatures for accelerated cooling (if applicable) and inspection
- final plate heat treatment, e.g. quench and tempering (if applicable)
- method used to cut and separate the metallurgically roll bonded plates after rolling (separation of the sandwich between the CRA layers)
- details regarding any CRA clad welding to pipe ends.

MPS for lined linepipe

302 In addition to the applicable information given in A700 and A800, the MPS for lined linepipe shall as a minimum contain the following information (as applicable):

- details for fabrication of backing pipe and liner
- quality control checks for the lining process

- details of data to be recorded (e.g. expansion pressure/force, strain, deformation)
- procedure for cut back prior to seal welding or cladding to attach liner to carrier pipe
- seal welding procedures
- details regarding any CRA clad welding to pipe ends.

303 The following additional essential variable applies to the qualification of the MPS for clad linepipe (see A807):

- sequence of welding.

D 400 Manufacturing

401 During all stages of manufacturing, contamination of CRA with carbon steel shall be avoided. Direct contact of the CRA layer with carbon steel handling equipment (e.g. hooks, belts, rolls, etc.) is prohibited. Direct contact may be allowed providing subsequent pickling is performed.

402 All work shall be undertaken in clean areas and controlled environment to avoid contamination and condensation.

403 In addition to the requirements stated in B300 and C300 (as applicable), the following shall apply:

Welding consumables

404 The welding consumables for seam welds and liner seal welds shall be selected taking into consideration the reduction of alloying elements by dilution of iron from the base material. The corrosion properties of the weld consumable shall be equal or superior to the clad or liner material.

General requirements to manufacture of clad linepipe

405 The cladding alloy shall be produced from plate, and shall be supplied in a solution or soft annealed condition, as applicable.

406 The steel backing material and the cladding alloy shall be cleaned, dried and inspected to ensure that the level of humidity and particles between the respective plates are equal to or less than for the MPQT plates.

407 The mating plate surfaces should as a minimum be blast cleaned to a surface cleanliness of ISO 8501 Sa2.

408 A pre-clad rolling assembly procedure shall be part of the MPS. This procedure shall include details of all surface preparation to be performed just prior to the sandwich assembly (if applicable).

409 The sandwich or one-side-open packages, as applicable, shall be hot rolled in order to ensure metallurgical bonding between the base and the cladding material.

410 The package consisting of sandwich or one-side-open, shall be manufactured through a TMCP route, or receive a final heat treatment (e.g. QT).

Welding of clad linepipe

411 In addition to the applicable requirements given in B307 to B331, the following requirements shall apply for welding of clad linepipe:

- the corrosion properties of the CRA weld consumable (e.g. root and hot pass) shall be equal or superior to the clad material
- except for single pass per side welds, the longitudinal weld shall be back purged with welding grade inert gas and be free from high temperature oxides
- tack welds shall be made using GTAW, GMAW, G-FCAW or SMAW using low hydrogen electrodes
- weld seam tracking of continuous welding shall be automatically controlled.

General requirements to manufacture of lined linepipe

412 The liner for lined pipe shall be manufactured according to API 5LC.

413 The internal surface of the C-Mn steel backing pipe shall be blast cleaned to a surface cleanliness of ISO 8501 Sa2 along the complete length of the pipe prior to fabrication of lined pipe. The external surface of the liner pipe shall be blast cleaned as specified above or pickled.

414 The liner pipe shall be inserted into the backing C-Mn steel pipe after both pipes have been carefully cleaned, dried and inspected to ensure that the level of humidity and particles in the annular space between these two pipes are equal to or less than for the MPQT pipes.

415 The humidity during assembly shall be less than 80%, and the carbon steel and CRA surfaces shall be maintained at least 5°C above the dew point temperature. Temperature and humidity shall continuously be measured and recorded.

416 After having lined up the two pipes, the liner shall be expanded by a suitable method to ensure adequate gripping. The carbon steel pipe shall not receive a sizing ratio, s_r , exceeding 0.015 during the expansion process (See B332).

Welding of lined linepipe

417 The liner for lined pipe shall be welded according to API 5LC.

418 Seal welds, i.e. pipe end clad welds or fillet welds, shall be qualified according to Appendix C E400, E605 and E606, respectively. Production welding shall follow the principles in Appendix C.

419 Subsequent to expansion, the liner or backing pipe shall be machined at each end and further fixed to the backing pipe by a seal weld (clad or fillet weld) to ensure that no humidity can enter the annulus during storage, transportation and preparation for installation.

420 In addition to the applicable requirements given in B307 to B331, the following requirements shall apply for welding of lined linepipe:

- the corrosion properties of the CRA weld consumable (e.g. fillet or clad weld) shall be equal or superior to the liner material
- the weld shall be purged with welding grade inert gas and be free from high temperature oxides.

D 500 Acceptance criteria

Properties of the backing material

501 The backing material of the manufactured clad or lined linepipe shall comply with the requirements for C-Mn steel given in Subsection B. H₂S service requirements according to I100 shall not apply to the backing material unless required according to I115.

502 The cladding/liner material shall be removed from the test pieces prior to mechanical testing of the backing material.

Hardness

503 The hardness of the base material, cladding material, HAZ, weld metal and the metallurgical bonded area shall meet the relevant requirements of this standard.

Bonding strength of clad linepipe

504 After bend testing in accordance with App.B B509 (see Table 7-14), there shall be no sign of cracking or separation on the edges of the specimens.

505 After longitudinal weld root bend testing in accordance with App.B B507 (see Table 7-15), the bend test specimen shall not show any open defects in any direction exceeding 3 mm. Minor ductile tears less than 6 mm, originating at the specimen edge may be disregarded if not associated with obvious defects.

506 The minimum shear strength shall be 140 MPa.

Properties of the CRA of clad and lined linepipe

507 The CRA material shall meet the requirements of the relevant reference standard, e.g. API 5LD.

Chemical composition of welds

508 The chemical composition of the longitudinal seam weld (or overlay weld if applicable) of clad pipes, pipe end clad welds, and the liner seal welds (if exposed to the pipe fluid), shall be analysed during MPQT. The composition of the deposited weld metal as analysed on the exposed surface should meet the requirements of the base material specification.

The calculated PRE (see Table 7-10, note 2) for alloy 625 weld metal should not be less than for the clad pipe base material or liner material.

Microstructure

509 The weld metal and the HAZ in the root area of the clad pipe seam welds, any pipe end clad welds and the seal welds of lined pipe shall be essentially free from grain boundary carbides, nitrides and intermetallic phases.

Gripping force of lined linepipe

510 Acceptance criteria for gripping force production testing shall be agreed based on project specific requirements (see Sec.6 B400) and/or test results obtained during MPQT.

Liner collapse

511 After the test for presence of moisture in the annulus between the liner and the backing material, the pipe shall be inspected and no ripples or buckles in the liner or carbon steel pipe shall be in evidence when viewed with the naked eye.

D 600 Inspection

601 Compliance with the requirements of the purchase order shall be checked by specific inspection in accordance with EN 10204. Records from the qualification of the MPS and other documentation shall be in accordance with the requirements in Sec.12.

Inspection frequency

602 The inspection frequency during production and MPQT shall be as given in Table 7-14 and Table 7-15, respectively.

603 For clad pipe, the number and orientation of the samples shall be as for SAWL pipe in Table 7-9

604 For lined pipe, the number and orientation of the samples for the backing steel shall be according to Table 7-9. Testing of the liner for lined pipe shall be according to API 5LC.

Retesting

605 Requirements for retesting shall be according to B507 to B511.

Heat and product analysis

606 Heat and product analysis shall be performed in accordance with B500 and C500 for the backing steel and the CRA liner or cladding, respectively.

Mechanical testing

607 All mechanical testing of clad pipe and the backing steel of lined pipe shall be performed according to Appendix B. Mechanical testing of the liner for lined pipe shall be according to API 5LC.

608 Hardness testing of welded linepipe shall be performed on a test piece comprising the full cross section of the weld. Indentations shall be made in the base material, cladding material and the metallurgical bonded area as detailed in Appendix B.

Corrosion testing

609 Unless specified by purchaser, corrosion testing of roll bonded clad pipes or any longitudinal weld seams is not required.

Guidance note:

ASTM G48 Method A testing is relevant in case flooding with raw sea water of material clad/lined with Alloy 625 is a design requirement/assumption. Such testing is not relevant if the CRA material is UNS S31600, UNS S31603 or UNS N08825.

---e-n-d---of---G-u-i-d-a-n-c-e---n-o-t-e---

Metallographic examination

610 Metallographic examination shall be performed in accordance with Appendix B.

Liner collapse test

611 To check for the presence of moisture in the annulus between the liner and the backing material, one finished pipe or a section thereof (minimum length of 6 m) shall be heated to 200°C for 15 minutes and air cooled. This pipe shall be within the first 10 pipes produced.

Gripping force test

612 Gripping force of lined pipe shall be measured in accordance with API 5LD. Equivalent tests may be applied subject to agreement. Inspection frequency for production testing shall be agreed based on test results obtained during the MPQT (see D300).

Hydrostatic test (mill pressure test)

613 Hydrostatic testing shall be performed in accordance with Subsection E.

Non-destructive testing

614 NDT, including visual inspection, shall be in accordance with Subsection F.

Dimensional testing

615 Dimensional testing shall be performed according to Subsection G.

Treatment of surface imperfections and defects

616 Surface imperfections and defects shall be treated according to App.D H300.

Applicable to	Type of test	Frequency of testing	Acceptance criteria
All pipe	All tests in Table 7-7 applicable to “All pipe”	See Table 7-7 and D600	D501
Clad pipe	All tests in Table 7-7 applicable to “SAWL”		
	Clad pipe	Bend tests (2 specimens)	Once per test unit of not more than 50 pipes
Shear strength		D506	
CRA material of clad pipe	According to reference standard (see D507)		
Liner pipe	According to API 5LC (see D507)		
Lined pipe	Macrographic examination of seal weld	Once per test unit of not more than 50 pipes	App.C F405
	Gripping force test	To be agreed, see D612	D510

Applicable to	Type of test	Frequency of testing	Acceptance criteria
All pipe	All production tests in Table 7-14	One test for each pipe provided for manufacturing procedure qualification	See Table 7-14
	Relevant qualification tests in Table 7-8		See Table 7-8
	Corrosion testing of welds, if agreed, see D609		To be agreed
Clad pipe	Chemical composition of seam weld and clad weld ²⁾		D508
	Metallographic examination of the seam weld and clad weld ²⁾		D509
	Longitudinal weld root bend test		D505
Lined pipe	Chemical composition of seal or clad welds ²⁾		D508
	Metallographic examination of seal welds		D509
	Liner collapse test		D511

Notes

1) Sampling of specimens and test execution shall be performed in accordance with Appendix B. The number, orientation and location of test pieces per sample for mechanical tests shall be according to D603 and D604.

2) As applicable, according to D508 and D509.

E. Hydrostatic Testing

E 100 Mill pressure test

101 Each length of linepipe shall be hydrostatically tested, unless the alternative approach described in E107 is used.

102 The test pressure (p_h) shall, in situations where the seal is made on the inside or the outside of the linepipe surface, be conducted at the lowest value obtained by utilising the following formulae:

$$p_h = \frac{2 \cdot t_{\min}}{D - t_{\min}} \cdot \min[SMYS \cdot 0.96; SMTS \cdot 0.84] \quad (7.2)$$

103 In situations where the seal is made against the end face of the linepipe by means of a ram or by welded on end caps, and the linepipe is exposed to axial stresses, the test pressure shall be calculated such that the maximum combined stress equals:

$$s_e = \min[SMYS \cdot 0.96; SMTS \cdot 0.84] \quad (7.3)$$

based on the minimum pipe wall thickness t_{\min} .

Guidance note:

The Von Mises Equivalent stress shall be calculated as:

$$s_e = \sqrt{s_h^2 + s_l^2 - s_h \cdot s_l} \quad (7.4)$$

where

$$s_h = \frac{p_h \cdot (D - t_{\min})}{2 \cdot t_{\min}} \quad (7.5)$$

$$s_l = \frac{N}{A_s} \quad (7.6)$$

N = True pipe wall force which depend on the test set up end restraints.

(t_{\min} is equivalent to t_1 in Sec.5)

---e-n-d---of---G-u-i-d-a-n-c-e---n-o-t-e---

104 For pipes with reduced pressure containment utilisation, the test pressure (p_h) may be reduced as permitted in Sec.5 B200.

105 In case significant corrosion allowance has been specified (as stated by the Purchaser in the material specification), or a large wall thickness is needed for design purposes other than pressure containment, or significant temperature de-rating of the mechanical properties take place, the mill test pressure may be significantly higher than the incidental pressure. For such conditions and where the mill pressure test capacity is limited, the mill test pressure may be limited to $p_h = 1.4 \cdot p_{li}$, (where p_{li} is the local incidental pressure).

106 The test configuration shall permit bleeding of trapped air prior to pressurisation of the pipe. The pressure test equipment shall be equipped with a calibrated recording gauge. The applied pressure and the duration of each hydrostatic test shall be recorded together with the identification of the pipe tested. The equipment shall be capable of registering a pressure drop of minimum 2% of the applied pressure. The holding time at test pressure shall be minimum 10 seconds. Calibration records for the equipment shall be available.

107 Subject to agreement, the hydrostatic testing may be omitted for expanded pipes manufactured by the UOE process. It shall in such situations be documented that the expansion process and subsequent pipe inspection will:

- ensure that the pipe material stress-strain curve is linear up to a stress corresponding to E102
- identify defects with the potential for through-thickness propagation under pressure loading
- identify pipes subject to excessive permanent deformation under pressure loading to a degree equivalent to that provided by hydrostatic testing.

Workmanship and inspection shall be at the same level as for hydrostatically tested pipe.

The expansion process parameters and inspection results shall be recorded for each pipe.

F. Non-destructive Testing

F 100 Visual inspection

101 Visual inspection shall be in accordance with App.D H500.

102 If visual inspection for detection of surface imperfections is substituted with alternative inspection methods then the substitution shall conform to the requirements in App.D H505.

F 200 Non-destructive testing

201 Requirements for Non-Destructive Testing (NDT) of linepipe are given in App.D, Subsection H.

202 Requirements for NDT (laminar imperfections) and visual examination of plate, coil and strip performed at plate mill are given in App.D, Subsection G.

203 Table 7-16 lists the required NDT of linepipe including lamination check for welded linepipe. For welded pipe, lamination checks may be performed on linepipe or plate/strip at the discretion of the Manufacturer.

204 Alternative test methods may be accepted subject to agreement according to App.D, H401 and H402.

<i>Applicable to</i>	<i>Scope of testing</i>	<i>Type of test ²⁾</i>	<i>Frequency of testing</i>	<i>Reference (Appendix D)</i>
All	Visual inspection	-	100%	H500
	Residual magnetism	-	5% ³⁾	H500
	Imperfections in un-tested ends	UT+ST	100% or cut off	H600
Pipe ends of all pipe	Laminar imperfections pipe ends ⁴⁾	UT	100%	H700
	Laminar imperfections pipe end face/bevel	ST	100%	
SMLS	Laminar imperfections in pipe body	UT	100%	H800
	Longitudinal imperfections in pipe body	UT	100%	
	Transverse imperfections in pipe body	UT	100/10% ⁶⁾	
	Wall thickness testing	UT	100% ⁷⁾	
	Longitudinal surface imperfections in pipe body ⁵⁾	ST	100/10% ⁶⁾	
HFW, EBW and LBW	Laminar imperfections in pipe body	UT	100%	H900
	Laminar imperfections in area adjacent to weld	UT	100%	
	Longitudinal imperfections in weld	UT	100%	
SAWL, SAWH and MWP	Laminar imperfections in pipe body	UT	100%	H1300
	Laminar imperfections in area adjacent to weld	UT	100%	
	Imperfections in weld	UT	100%	
	Surface imperfections in weld area ⁵⁾	ST	100%/R ⁸⁾	
	Imperfections at weld ends	RT	100%	
Clad pipe	Lack of bonding in pipe body and pipe ends ⁹⁾	UT	100%	H1200
	Laminar imperfections in pipe body	UT	100%	
	Longitudinal and transverse imperfections in weld	UT	100%	
	Laminar imperfections in area adjacent to weld	UT	100%	
	Surface imperfections in weld area	ST	100%/R ¹⁰⁾	
	Imperfections in welds	RT	100%	
CRA liner pipe	Longitudinal and transverse imperfections in weld	EC or RT	100%	H1000
Lined pipe	As required for the type of backing material used, see above	-	100%	-
	Seal and clad welds	ST	100%	H1100
	Clad welds (bonding imperfections)	UT	100%	

Notes

- The indicated test methods are considered to be industry standard. Alternative methods may be used as required in App.D H400.
- Nomenclature: UT = ultrasonic testing, ST = surface testing, e.g. magnetic particle testing or EMI (flux leakage) for magnetic materials and liquid penetrant testing for non-magnetic materials, RT = radiographic testing and EC = eddy current testing, see Appendix D.
- 5% = testing of 5% of the pipes produced but at least once per 4 hour per operating shift.
- Laminar inspection is not applicable to pipe with $t \leq 5$ mm. Standard width of band to be tested is 50 mm, but a wider band may be tested if specified by the Purchaser.
- Applicable to external surface only.
- 100/10% = 100% testing of the first 20 pipes manufactured and if all pipes are within specification, thereafter random testing (minimum five pipes per 8-hour shift) during the production of 10% of the remaining pipes.
- The wall thickness shall be controlled by continuously operating measuring devices.
- 100%/R = 100% testing of the first 20 pipes manufactured. If all pipes are within specification, thereafter random testing of a minimum of one pipe per 8-hour shift.
- Applies to pipe ends irrespective if clad welds are applied to pipe ends or not.
- For external weld Note 8) shall apply. For internal weld the frequency shall be 100%.

G. Dimensions, Mass and Tolerances

G 100 General

101 Linepipe shall be delivered to the dimensions specified in the material specification, subject to the applicable tolerances.

102 The pipe shall be delivered in random lengths or approximate length, as specified in the material specification.

G 200 Tolerances

201 The diameter and out-of-roundness shall be within the tolerances given in Table 7-17. The minus tolerances for diameter and out-of-roundness do not apply for defects completely removed by grinding, according to App.D H308 and H309.

202 The wall thickness shall be within the tolerances given in Table 7-18.

203 Geometric deviations, pipe straightness, end squareness and weight shall be within the tolerances given in Table 7-19.

204 The minimum average length of pipe should be 12.1 m, and the tolerances for length according to Table 7-19.

Guidance note:

The average length of 12.1 m is based upon the optimum lengths for handling on several 'S-lay' barges in operation, but this could change in the course of time. An average length of 12.1 m is not necessarily optimum for deepwater 'J-lay' practice and can vary according to the 'J-lay' system used. It is the responsibility of the purchaser to agree with both the linepipe manufacturer and the pipe-lay contractor the length range to be supplied.

The following should be considered:

- Will the installation method benefit from another standard linepipe length?
- Should a significant quantity of the delivered linepipes (subject to agreement) be within ± 0.2 m or ± 0.1 m of the required standard linepipe length?

---e-n-d---of---G-u-i-d-a-n-c-e---n-o-t-e---

Tolerances for the weld seam

205 Tolerances for the weld seam of welded pipe, i.e.:

- cap reinforcement MR*
- root penetration MR*
- weld interpenetration (for double-sided SAW only) MR*
- cap and root concavity
- radial offset
- misalignment of weld beads for double sided welds
- deviation of the weld toe from a straight line
- undercut
- arc burns
- start/stop craters/poor restart
- surface porosity
- cracks
- lack of penetration/lack of fusion
- systematic imperfections
- burn through.

shall be within the tolerances given in App.D Table D-4.

*) MR indicates that the requirement is modified compared to ISO 3183.

206 Requirements for dents are given in App.D H500.

G 300 Inspection

301 The frequency of dimensional testing shall be according to Table 7-17 through Table 7-19.

302 Suitable methods shall be used for the verification of conformance with the dimensional and geometrical tolerances. Unless particular methods are specified in the purchase order, the methods to be used shall be at the discretion of the Manufacturer.

The manufacturer shall ensure sufficient training and instruction of the personnel, in order to provide a stable and repeatable inspection practice.

Guidance note:

When measuring the linepipe dimensions and geometrical features it is important to consider that each parameter (e.g. wall thickness, diameter, out-of-roundness etc) is fully independent of the others. This means that the linepipe should be considered to have nominal values for all parameters, except the one parameter being measured.

This might not fully reflect the reality; the pipe out-of-roundness may very well influence the diameter, and the wall thickness variations can influence offset measurements and diameter measurements. Still, in order to have a common approach to linepipe dimensions and geometry inspection it is important to consider one feature at a time.

It is not allowed to add tolerances (e.g. local geometry deviation + out-of-roundness + weld offset) in order to tweak the acceptance criteria.

---e-n-d---of---G-u-i-d-a-n-c-e---n-o-t-e---

303 All test equipment shall be calibrated, and the measurement resolution shall be sufficient to properly evaluate the tolerances. Dimensional testing by automatic measuring devices is acceptable provided the accuracy and precision of the measuring devices is documented and found to be within acceptable limits.

304 Diameter and out-of-roundness shall be determined separately. Diameter measurements shall be based on circumferential measurements using tape, ruler or calliper type gauges, or automatic devices as appropriate. The out-of-roundness is the difference between the largest and smallest diameter in a given cross-sectional plane (the weld cap shall not be taken into account). The out-of roundness should be measured using a rod gauge and rotate this around the circumference in a given cross section in order to search for the largest and smallest diameter. Alternatively, this could be measured using an automatic measuring device. The acceptance criteria in Table 7-17 shall be met. MR

Guidance note:

The diameter requirement is based on the nominal diameter of the linepipe. The out-of-roundness requirement is based on the specified nominal outside diameter as stated in Table 7-17 and 7-26.

---e-n-d---of---G-u-i-d-a-n-c-e---n-o-t-e---

305 At pipe ends inside (i.e. pipe internal surface) measurements shall be used to determine diameter and out-of-roundness. For linepipe with internal diameter less than 150 mm outside measurements are allowed. MR.

306 Pipe body diameter and out-of-roundness shall be measured towards the middle of the pipe. The choice between inside or outside measurements is at the manufacturer's discretion.

307 The wall thickness at any location of every pipe shall be within the tolerances in Table 7-18, except that the weld area shall not be limited by the plus tolerance. Wall thickness measurements shall be made with an automatic or manual non-destructive device, or mechanical calliper. In case of dispute, the measurement determined by use of the mechanical calliper shall govern. The mechanical calliper shall be fitted with contact pins having circular cross sections of 6.35 mm in diameter. The end of the pin contacting the inside surface of the pipe shall be rounded to a maximum radius of 38.1 mm for pipe of size 168.3 mm or larger, and up to a radius of $d/4$ for pipe smaller than size 168.3 mm with a minimum radius of 3.2 mm. The end of the pin contacting the outside surface of the pipe shall be either flat or rounded to a radius of not less than 38.1 mm.

308 Geometric deviations from the nominal cylindrical contour of the pipe (e.g. flat spots and peaks) resulting from the pipe forming or manufacturing operations (i.e. not including dents) shall not exceed the criteria in Table 7-19. Geometric deviations shall be measured as the gap between the extreme point (i.e. deepest or highest) of the deviation and the prolongation of the contour of the pipe. A template with a curvature equal to the nominal ID/OD of the pipe to be inspected shall be used. The length of the gauges shall be 200 mm or 0.25 D, whichever is less. The gauges shall be made with a notch so that it can fit over the weld cap.

At pipe ends the full internal circumference shall be inspected, over a length of minimum 50 mm from the pipe end level.

Inspection of the external surface shall be performed along the weld and around the circumference whenever indicated by visual inspection. MR

309 Straightness shall be measured according to Figure 1 and Figure 2 in ISO 3183.

310 Out-of squareness at pipe ends shall be measured according to Figure 3 in ISO 3183.

311 For pipe with $D \geq 141.3$ mm, each linepipe shall be weighed individually. For pipe with $D < 141.3$ mm, the linepipes shall be weighed either individually or in convenient lots selected by the Manufacturer.

312 The mass per unit length, r_1 , shall be used for the determination of pipe weight and shall be calculated using the following equation:

$$r_1 = t(D-t) \cdot C \quad (7.7)$$

where:

- r_1 is the mass per unit length, in kg/m
- D is the nominal outer diameter, expressed in mm
- t is the nominal wall thickness, in mm
- C is 0.02466.

313 All specified tests shall be recorded as acceptable or non-acceptable.

314 The actual minimum and maximum value for wall thickness and the diameter of pipe ends and maximum out-of-roundness at pipe ends shall be recorded for 10% of the specified tests, unless a higher frequency is agreed. For weight and length 100% of the actual measurement results shall be recorded. During MPQT the

actual value of all parameters for all inspected pipes shall be recorded.

Table 7-17 Tolerances for diameter and out-of-roundness							
<i>D</i> [mm]	Frequency of inspection	Diameter				Out-of-roundness	
		Pipe body ¹⁾		Pipe end ^{2, 3)}		Pipe body ²⁾	Pipe end ³⁾
		SMLS	Welded	SMLS	Welded		
< 60.3	Once per test unit ⁴⁾	± 0.5 mm or ± 0.0075 <i>D</i> , whichever is greater	± 0.5 mm or ± 0.0075 <i>D</i> , whichever is greater, but max. ± 3.2 mm	± 0.5 mm or ± 0.005 <i>D</i> , whichever is greater, but max. ± 1.6 mm		Included in the diameter tolerance	
≥ 60.3 ≤ 610						0.015 <i>D</i>	0.01 <i>D</i>
> 610 ≤ 1422		± 0.01 <i>D</i>	± 0.005 <i>D</i> , but max. ± 4.0 mm	± 2.0 mm	± 1.6 mm	0.01 <i>D</i> but max. 10 mm for <i>D/t</i> ≤ 75 By agreement for <i>D/t</i> > 75	0.0075 <i>D</i> but max. 8 mm for <i>D/t</i> ≤ 75 By agreement for <i>D/t</i> > 75
> 1422		as agreed					

where
D = Specified outside diameter
t = specified nominal wall thickness.

Notes

- 1) Dimensions of pipe body to be measured approximately in the middle of the pipe length.
- 2) For SMLS pipe, the tolerances apply for *t* ≤ 25.0 mm, and the tolerances for heavier wall pipe shall be as agreed.
- 3) The pipe end includes a length of 100 mm at each of the pipe extremities.
- 4) Once per test unit of not more than 20 lengths of pipe. For *D* ≤ 168.3 mm; once per test unit of not more than 100 lengths of pipe, but minimum one (1) and maximum 6 pipes per 8-hour shift. MR*

*) MR indicates that the requirement is modified compared to ISO 3183.

Table 7-18 Tolerances for wall thickness			
Type of pipe	Wall thickness [mm]	Frequency of inspection	Tolerances ¹⁾
SMLS	<i>t</i> < 4.0	100%	+ 0.6 mm - 0.5 mm
	4.0 ≤ <i>t</i> < 10.0		+ 0.15 <i>t</i> - 0.125 <i>t</i>
	10.0 ≤ <i>t</i> < 25.0		± 0.125 <i>t</i>
	<i>t</i> ≥ 25.0		+ 0.10 <i>t</i> or + 3.7 mm, whichever is greater MR* - 0.10 <i>t</i> or - 3.0 mm, whichever is greater MR*
HFW, EBW, LBW and MWP ²⁾	<i>t</i> ≤ 6.0	100%	± 0.4 mm
	6.0 < <i>t</i> ≤ 15.0		± 0.7 mm
	<i>t</i> > 15.0		± 1.0 mm
SAW ³⁾	<i>t</i> ≤ 6.0	100%	± 0.5 mm
	6.0 < <i>t</i> ≤ 10.0		± 0.7 mm
	10.0 < <i>t</i> ≤ 20.0		± 1.0 mm
	<i>t</i> > 20.0		+ 1.5 mm - 1.0 mm

Where
t = specified nominal wall thickness.

Notes

- 1) If the purchase order specifies a minus tolerance for wall thickness smaller than the applicable value given in this table, the plus tolerance for wall thickness shall be increased by an amount sufficient to maintain the applicable tolerance range.
- 2) Subject to agreement a larger plus tolerance for metallurgically clad pipes may be applied.
- 3) The plus tolerance for wall thickness does not apply to the weld area.

Table 7-19 Tolerances for pipe geometric properties not covered in Table 7-17 and 7-18		
<i>Characteristic to be tested</i>	<i>Frequency of inspection</i>	<i>Tolerances</i>
Geometric deviations (peaking and flats) ¹⁾	10% ²⁾	0.005 <i>D</i> or 2.5 mm, whichever is less
Straightness, max. for full length of pipe	5% ²⁾	≤ 0.0015 <i>L</i>
Straightness, max. deviation for pipe end region ³⁾		3 mm
Out-of squareness at pipe ends		≤ 1.6 mm from true 90°
Length	100%	min. 11.70 m and max. 12.70 m
Weight of each single pipe / pipe bundle		-3.5% / +10% of nominal weight
Tolerances for the pipe weld seam and dents	see G205 and G206	
where <i>L</i> = actual length of pipe		
<i>Notes</i>		
1) Applicable to welded pipes only		
2) Testing of the required percentage of the pipes produced but minimum 3 pipes per 8-hour shift.		
3) The pipe end region includes a length of 1.0 m at each of the pipe extremities.		

H. Marking, Delivery Condition and Documentation

H 100 Marking

101 All marking shall be easily identifiable and durable in order to withstand pipe loading, shipping, and normal installation activities.

102 Marking shall include DNV linepipe designation (ref. B200, C200 and D200). Other type of marking shall be subject to agreement.

103 Each linepipe shall be marked with a unique number. The marking shall reflect the correlation between the product and the respective inspection document.

H 200 Delivery condition

201 The delivery condition of C-Mn steel pipe shall be according to Table 7-1.

202 The internal surface of CRA pipes shall be pickled in accordance with the purchase order. If agreed the external surface of CRA pipes shall be cleaned.

H 300 Handling and storage

301 On customer's request, each linepipe shall be protected until taken into use.

302 For temporary storage see Sec.6 D300.

H 400 Documentation, records and certification

401 Linepipe shall be delivered with Inspection Certificate 3.1 according to European Standard EN 10204 (*Metallic Products - Types of Inspection Documents*) or an accepted equivalent.

402 Inspection documents shall be in printed form or in electronic form as an EDI transmission that conforms to any EDI agreement between the Purchaser and the manufacturer.

403 The Inspection Certificate shall identify the products represented by the certificate, with reference to product number, heat number and heat treatment batch. The specified outside diameter, specified wall thickness, pipe designation, type of pipe, and the delivery condition shall be stated.

404 The certificate shall include or refer to the results of all specified inspection, testing and measurements including any supplementary testing specified in the purchase order. For HFW pipe, the minimum temperature for heat treatment of the weld seam shall be stated.

405 Records from the qualification of the MPS and other documentation shall be in accordance with the requirements in Sec.12 C100.

I. Supplementary Requirements

I 100 Supplementary requirement, H2S service (S)

101 Linepipe for H₂S service (also referred to as sour service) shall conform to the requirements below. Sec.6 B200 provides guidance for material selection.

102 All mandatory requirements in ISO 15156-2/3 shall apply, in combination with the additional

requirements of this standard.

Guidance note:

ISO 15156-1/2/3, Sec.1, states that the standard is only applicable “to the qualification and selection of materials for equipment designed and constructed using conventional elastic design criteria”. Any detrimental effects of induced strain will only apply if these are imposed during exposure to an H₂S-containing environment; hence, for manufacture and installation of pipelines the restrictions imposed in the ISO standard are applicable also to strain based design. Any restrictions for maximum allowable strain during operation are beyond the scope of this standard.

---e-n-d---of---G-u-i-d-a-n-c-e---n-o-t-e---

C-Mn steel

103 C-Mn steel linepipe for H₂S service shall conform to Subsection B, and to the modified and additional requirements below, which conform to the requirements in ISO 3183 Annex H: “PSL 2 pipe ordered for sour service”.

104 The chemical compositions given in Table 7-3 and Table 7-4 shall be modified according to Table 7-20 and Table 7-21, respectively.

Table 7-20 Chemical composition for SMLS and welded C-Mn steel pipe with delivery condition N or Q for Supplementary requirement, H₂S service

SMYS	Product analysis, maximum. weight %			
	C ¹⁾	Mn ¹⁾	S ²⁾	Other ³⁾
Pipe with delivery condition N - according to Table 7-1				
245	-	-	0.003	-
290	-	-	0.003	-
320	-	-	0.003	-
360	-	-	0.003	-
Pipe with delivery condition Q - according to Table 7-1				
245	-	-	0.003	-
290	-	-	0.003	-
320	-	-	0.003	-
360	-	-	0.003	-
390	-	-	0.003	-
415	-	-	0.003	Note ⁴⁾
450	-	-	0.003	Note ⁴⁾
485	0.16	1.65	0.003	Notes ^{4, 5)}

Notes

- 1) For each reduction of 0.01% below the specified maximum for carbon, an increase of 0.05% above the specified maximum for manganese is permissible, up to a maximum increase of 0.20%.
- 2) If agreed the sulphur content may be increased to ≤ 0.008% for SMLS and ≤ 0.006% for welded pipe, and in such cases lower Ca/S may be agreed.
- 3) Unless otherwise agreed, for welded pipe where calcium is intentionally added, Ca/S ≥ 1.5 if S > 0.0015%. For SMLS and welded pipe Ca ≤ 0.006%.
- 4) If agreed Mo ≤ 0.35%.
- 5) The maximum allowable P_{cm} value shall be 0.22 for welded pipe and 0.25 for SMLS pipe.

Table 7-21 Chemical composition for welded C-Mn steel pipe with delivery condition M for Supplementary requirement, H₂S service

SMYS	Product analysis, maximum. weight %			
	C ¹⁾	Mn ¹⁾	S ²⁾	Other ³⁾
245	0.10	-	0.002	-
290	0.10	-	0.002	-
320	0.10	-	0.002	-
360	0.10	1.45	0.002	-
390	0.10	1.45	0.002	-
415	0.10	1.45	0.002	Note ⁴⁾
450	0.10	1.60	0.002	Notes ⁴⁾
485	0.10	1.60	0.002	Notes ⁴⁾

Notes

1 to 4) See Table 7-20.

- 105** Vacuum degassing or alternative processes to reduce the gas content of the steel should be applied.
- 106** The molten steel shall be treated for inclusion shape control.
- 107** The requirements for mechanical properties in B400 shall apply, except for the hardness.
- 108** During MPQT and production, the hardness in the pipe body, weld and HAZ shall not exceed 250 HV10. If agreed, (see ISO 15156-2) and provided the parent pipe wall thickness is greater than 9 mm and the weld cap is not exposed directly to the H₂S environment, 275 HV10 is acceptable for the weld cap area.

Guidance note:

It is recommended to specify a maximum hardness of 235 HV10 for the base material in order to allow for hardness increase during installation girth welding. If 275 HV10 is allowed in the cap area, the hardness in the corresponding base metal should be limited to 250 HV10.

---e-n-d---of---G-u-i-d-a-n-c-e---n-o-t-e---

- 109** Any hard spot larger than 50 mm in any direction, see Table 7-7, shall be classified as a defect if its hardness, based upon individual indentations, exceeds:

- 250 HV10 on the internal surface of the pipe, or
- 275 HV10 on the external surface of the pipe.

Pipes that contain such defects shall be treated in accordance with App.D H300.

- 110** The acceptance criteria for the HIC test shall be the following, with each ratio being the maximum permissible average for three sections per test specimen when tested in Solution (Environment) A (see Table B.3 of ISO 15156-2):

- crack sensitivity ratio (CSR) $\leq 2\%$
- crack length ratio (CLR) $\leq 15\%$, and
- crack thickness ratio (CTR) $\leq 5\%$.

If HIC tests are conducted in alternative media (see App.B B302) to simulate specific service conditions, alternative acceptance criteria may be agreed.

- 111** By examination of the tension surface of the SSC specimen under a low power microscope at X10 magnification there shall be no surface breaking fissures or cracks, unless it can be demonstrated that these are not the result of sulphide stress cracking.

CRA linepipe

- 112** CRA linepipe for H₂S service shall conform to Subsection C, and the recommendations given in Sec.6 B200.

- 113** Linepipe grades, associated hardness criteria, and requirements to manufacturing/fabrication shall comply with ISO 15156-3.

Clad or lined steel linepipe

- 114** Clad or lined steel or linepipe for H₂S service shall conform to Subsection D, and to the modified and additional requirements below.

- 115** Materials selection for cladding/liner, the associated hardness criteria, and requirements to manufacturing and fabrication shall comply with ISO 15156-3. The same applies to welding consumables for weldments exposed to the internal fluid. For selection of the C-Mn steel base material the considerations in A13.1 of ISO 15156-3 shall apply.

- 116** During qualification of welding procedures and production, hardness measurements shall be performed as outlined in Appendix B. The hardness in the internal heat-affected zone and in the fused zone of the cladding/lining shall comply with relevant requirements of ISO 15156-3.

Specific inspection

- 117** The frequency of inspection shall be as given in Tables 7-7, 7-8, 7-12, 7-13, 7-14 and 7-15 as relevant, and with additional testing given in Table 7-22.

- 118** HIC testing during production shall be performed on one randomly selected pipe from each of the three (3) first heats, or until three consecutive heats have shown acceptable test results. After three consecutive heats have shown acceptable test results, the testing frequency for the subsequent production may be reduced to one test per casting sequence of not more than ten (10) heats.

- 119** If any of the tests during the subsequent testing fail, three pipes from three different heats of the last ten heats, selecting the heats with the lowest Ca/S ratio (based on heat analysis), shall be tested, unless the S level is below 0.0015. For heat with S level greater than 0.0015 heats shall be selected with the lowest Ca/S ratio. Providing these three tests show acceptable results, the ten heats are acceptable. However, if any of these three tests fail, then all the ten heats shall be tested. Further, one pipe from every consecutive heat shall be tested until the test results from three consecutive heats have been found acceptable. After three consecutive heats have shown acceptable test results, the testing frequency may again be reduced to one test per ten heats.

SSC test

120 SSC testing is required unless the pipe material is pre-qualified in ISO 15156, see Sec.6 B202. If the material is pre-qualified, the purchaser may specify SSC testing. SSC testing shall be performed in accordance with ISO 15156 2/3 as applicable. (see Sec.6 B202).

Table 7-22 Applicable testing for Supplementary requirement S¹⁾			
Type of pipe	Type of test	Frequency of testing	Acceptance criteria
<i>Production tests</i>			
Welded C-Mn steel pipe	HIC test	In accordance with I118 and I119	I110
<i>Tests for Manufacturing Procedure Qualification Test</i>			
Type of pipe	Type of test	Frequency of testing	Acceptance criteria
Welded C-Mn steel pipe	HIC test	One test (3 test pieces) for each pipe provided for manufacturing procedure qualification	I110
All pipe ²⁾	SSC test		I111
<i>Notes</i>			
1) Sampling of specimens and test execution shall be performed in accordance with Appendix B.			
2) SSC testing is required for C-Mn and low alloy steels with SMYS > 450 MPa, 13Cr martensitic stainless steels and other materials not listed for H ₂ S service in ISO 15156. See also Sec.6 B202.			

I 200 Supplementary requirement, fracture arrest properties (F)

201 The requirements to fracture arrest properties are valid for gas pipelines carrying essentially pure methane up to 80% usage factor (ref. Table 13-3), up to a pressure of 15 MPa, 30 mm wall thickness and 1120 mm diameter

Testing shall be according to Table 7-24.

202 A Charpy V-notch transition curve shall be established for the linepipe base material. The Charpy V-notch energy value in the transverse direction at T_{min} shall, as a minimum, meet the values given in Table 7-23. Five sets of specimens shall be tested at different temperatures, including T_{min} , and the results documented in the qualification report.

Properties of pipe delivered without final heat treatment

203 This paragraph does not apply to C-Mn linepipes delivered with a final heat treatment (e.g. normalising or quench and tempering), or 22Cr and 25Cr linepipes. A Charpy V-notch transition curve shall be established for the linepipe base material in the aged condition. The plastic deformation shall be equal to the actual deformation introduced during manufacturing (no additional straining is required). The samples shall be aged for 1 hour at 250°C. Five sets of specimens shall be tested at different temperatures, including T_{min} . The Charpy V-notch energy value in the transverse direction, at T_{min} , shall as a minimum meet the values given in Table 7-23 in the aged condition. Values obtained at other test temperatures are for information.

204 Drop Weight Tear Testing (DWTT) shall only be performed on all linepipes with outer diameter > 400 mm, wall thickness > 8 mm and SMYS > 360 MPa. A DWTT transition curve shall be established for the linepipe base material. Minimum five sets of specimens shall be tested at different temperatures, including T_{min} . Each set shall consist of two specimens taken from the same test coupon. The test shall be performed in accordance with Appendix B. The specimens tested at the minimum design temperature and all temperatures above, shall as a minimum, meet an average of 85% shear area with one minimum value of 75%.

205 If supplementary requirements for H₂S service as in I100 are specified for linepipe material with SMYS ≥ 450 MPa the acceptance criteria stated in I204 (average and minimum shear area) may be subject to agreement.

Table 7-23 Charpy V-notch Impact Test Requirements for Fracture Arrest Properties tested at T_{min} (Joules; Transverse Values; Average value of three full size base material specimens)^{1, 2)}				
Wall thickness	≤30 mm ³⁾			Notes
	D (mm)			
SMYS	≤610	≤820	≤1120	
245	40	40	40	1) Minimum individual results to exceed 75% of these values, (max 1 specimen per set) 2) The values obtained in the longitudinal direction, when tested, shall be at least 50% higher than the values required in the transverse direction. 3) Fracture arrest properties for larger wall thicknesses and diameters shall be subject to agreement (see Sec.5 D1100) 4) SMYS 550 for 22Cr, 25Cr and 13Cr
290	40	43	52	
360	50	61	75	
415	64	77	95	
450	73	89	109	
485	82	100	124	
555 ⁴⁾	103	126	155	

Table 7-24 Applicable testing for Supplementary requirement F			
<i>Production tests</i>			
<i>Type of pipe</i>	<i>Type of test</i>	<i>Frequency of testing</i>	<i>Acceptance criteria</i>
All pipe	DWT testing (with limitations give to dimensions in I204)	Once per test unit of not more than 50/100 ¹⁾ pipes	I204 (see also I205)
<i>Tests for Manufacturing Procedure Qualification Test</i>			
All pipe	CVN impact testing of the pipe body for establishment of transition curve	One test for each pipe provided for manufacturing procedure qualification	Table 7-23 ²⁾
Welded pipe except CRA pipe	CVN impact testing of the pipe body for establishment of transition curve, aged condition ³⁾		Table 7-23 ²⁾
All pipe	DWT testing of the pipe body for establishment of transition curve (with limitations give to dimensions in I204)		I204 (see also I205)
<i>Notes</i>			
1) Not more than 100 pipes with $D \leq 508$ mm and not more than 50 pipes for $D > 508$ mm.			
2) The values obtained in the longitudinal direction, when tested, shall at least be 50% higher than the values required in the transverse direction.			
3) See I203			

I 300 Supplementary requirement, linepipe for plastic deformation (P)

301 Supplementary requirement (P) is applicable to linepipe (including C-Mn backing steel for lined/clad pipes) when the total nominal strain in any direction from a single event exceeds 1.0% or accumulated nominal plastic strain exceeds 2.0%. The required testing is outlined in Table 7-25 and detailed below. The requirements are only applicable to single event strains below 5%.

302 For pipes delivered in accordance with supplementary requirement (P), tensile testing shall be performed in the longitudinal direction using proportional type specimens in accordance with Appendix B, in order to meet the requirements in I303. Tensile testing in the longitudinal direction according to Table 7-9 is not required.

303 The difference between the maximum and minimum measured base material longitudinal yield stress shall not exceed 100 MPa prior to testing according to I304. This is applicable for C-Mn steel with SMYS up to and including 450 MPa, otherwise subject to agreement.

Guidance note:

The ratio YS/TS should not exceed 0.90 in order to have a reasonable strain-hardening capacity. This should be evaluated on a project-specific basis.

Buckling of the pipeline during on-reeling is primarily caused by strain concentrations in the pipeline. These strain concentrations are primarily caused by variation in thickness and yield stress along the pipeline. The strain hardening capability combined with a tighter tolerance on the yield stress are therefore good measures to mitigate these buckles.

---e-n-d---of---G-u-i-d-a-n-c-e---n-o-t-e---

Table 7-25 Additional testing for Supplementary requirement P¹⁾			
<i>Production tests</i>			
<i>Type of pipe</i>	<i>Type of test</i>	<i>Frequency of testing</i>	<i>Acceptance criteria</i>
All pipe	Tensile testing of the pipe body, longitudinal specimen of proportional type ²⁾	Once per test unit of not more than 50/100 ³⁾ pipes	I303
<i>Tests for Manufacturing Procedure Qualification Test (all testing on strained and aged samples)</i>			
Type of pipe	Type of test	Frequency of testing	Acceptance criteria
All pipe	Tensile testing of the pipe body, longitudinal specimen, strained and aged ²⁾	One test for one of the pipes provided for manufacturing procedure qualification	I308
	CVN impact testing of the pipe body		
	Hardness testing		
Welded pipe	Tensile testing of weld metal (all weld test)		I308
	CVN impact testing of the seam weld		
	Hardness testing of the seam weld		
<i>Notes</i>			
1) Mechanical and corrosion testing shall be performed in accordance with Appendix B.			
2) Proportional type specimens according to ISO 6892 shall be tested, see App.B B308.			
3) Not more than 100 pipes with $D < 508$ mm and not more than 50 pipes for $D \geq 508$ mm.			

304 As part of qualification of the pipe material, the finished pipe shall be deformed either by full scale or simulated deformation (see App.B B1102 to B1110) as stated by the Purchaser in the linepipe specification.

After the deformation, specimens for mechanical testing (see I306 and I307) shall be sampled in areas representative of the final deformation in tension, (see Appendix A). For full scale straining the test specimens, which shall represent the strain history ending up in tension, shall be extracted from the sector 5 to 7 o'clock of the pipe. 12 o'clock position is defined as the top of the pipe when reeling on.

The samples shall be artificially aged at 250°C for one hour before testing.

305 Qualification for Supplementary requirement P may be based on historical data to be documented by the Manufacturer, subject to agreement. This may be applied if all relevant parameters are identical (WT, ID, chemical composition, deformation scenario during installation (e.g. same or less onerous deformation scenario), steelmaking/rolling practice, heat treatments).

306 The following testing shall be conducted of the base material after straining and ageing:

- longitudinal tensile testing
- hardness testing
- Charpy V-notch impact toughness testing. Test temperature shall be according to Table 7-6.

307 The following testing shall be performed of the longitudinal weld seam after straining and ageing:

- weld metal (all weld) tensile test
- hardness testing
- Charpy V-notch test (transverse specimens).

308 The following requirements shall be met after straining and ageing (see I306 and I307):

- YS, TS and hardness shall be according to Table 7-5 or 7-11, as relevant. Only the minimum values apply for YS and TS, and maximum values for hardness.
- the elongation shall be minimum 15%
- Charpy V-notch impact toughness and hardness shall be according to Table 7-5 or 7-11, as applicable.

309 If the supplementary requirement for H₂S service (S) and/or fracture arrest properties (F) is required, the testing for these supplementary requirements shall be performed on samples that are removed, strained and artificially aged in accordance with I304. The relevant acceptance criteria shall be met.

I 400 Supplementary requirement, dimensions (D)

401 Supplementary requirements for enhanced dimensional requirements for linepipe (D) are given in Table 7-26. Implementing supplementary requirement D should be done by the Purchaser considering the influence of dimensions and tolerances on the subsequent fabrication/installation activities and the welding facilities to be used.

Guidance note:

Supplementary requirement D is beneficial for local buckling during reel-lay installation.

---e-n-d---of---G-u-i-d-a-n-c-e---n-o-t-e---

Table 7-26 Supplementary requirements D, enhanced tolerances and/or increased frequency of inspection ¹⁾

Type of pipe	Characteristic to be tested	Pipe diameter	Frequency of inspection	Tolerances
All, except Lined/Clad	Diameter pipe ends	-	Each pipe end	As per Table 7-17
	Out-of-roundness, pipe ends, $D/t \leq 75$	$610 < D \leq 1422$		$0.0075 D$, but max. 5.0 mm
SMLS	Wall thickness $t \geq 10.0$ mm	-	Each pipe	$\pm 0.10 t$, but max. ± 3.0 mm
SAW and HFW pipe	Wall thickness $t \leq 6.0$ mm	-		± 0.5 mm ²⁾
	Wall thickness $t > 6.0$ to ≤ 10.0 mm	-		± 0.6 mm ²⁾
	Wall thickness $t > 10.0$ to ≤ 20.0 mm	-		± 0.8 mm ²⁾
	Wall thickness $t \geq 20.0$ mm	-		± 1.0 mm ²⁾
	Geometric deviations (peaking and flats) at pipe ends	-	10%	$0.005 D$ or 1.5 mm, whichever is less
Lined/Clad	Diameter pipe ends	-	Each pipe end	± 1.0 mm
	Out-of-roundness pipe ends	-		$0.0075 D$, but max. 3.0 mm

where
 D = specified nominal outside diameter
 t = specified nominal wall thickness.

Notes

1) For tolerances not specified in this table, the dimensional tolerances in Table 7-17 to Table 7-19 shall apply.
 2) Subject to agreement a larger plus tolerance for metallurgically clad pipes may be applied.

I 500 Supplementary requirement, high utilisation (U)

501 For welded pipes, supplementary requirement U does only consider the SMYS at ambient temperature in the transverse direction. For seamless pipes delivered in the quenched and tempered condition testing may be conducted in the longitudinal direction.

502 The test regime given in this sub-section intends to ensure that the average yield stress is at least two standard deviations above SMYS. The testing scheme applies to production in excess of 50 test units. Alternative ways of documenting the same based upon earlier test results in the same production is allowed.

Guidance note:

The outlined test regime is required to be able to meet Supplementary requirement U, but as stated above, even if all tested pipes fulfil the requirements for the grade in question the pipes do not necessary fulfil the requirements for supplementary requirement U.

---e-n-d---of---G-u-i-d-a-n-c-e---n-o-t-e---

Mandatory mechanical testing

503 The testing frequency shall comply with Table 7-7 or Table 7-12, as applicable.

504 If the results from the mandatory testing meet the requirement $SMYS \times 1.03$, no further testing is required in order to accept the test unit.

505 If the result from the mandatory testing falls below SMYS, the re-test program given in I507 shall apply.

Confirmatory mechanical testing

506 If the mandatory test result falls between $SMYS \times 1.03$ and SMYS, then two (2) confirmatory tests taken from two (2) different pipes (a total of two tests) within the same test unit shall be performed.

If the confirmatory tests meet SMYS, the test unit is acceptable.

If one or both of the confirmatory tests fall below SMYS, the re-test program given in I508 shall apply.

Re-testing

507 If the result from the mandatory testing falls below SMYS, four (4) re-tests taken from four (4) different pipes (a total of 4 tests), within the same test unit, shall be tested. If the four re-tests meet SMYS, the test unit is acceptable. If one of the re-tests fall below SMYS the test unit shall be rejected.

508 If one or both of the confirmatory tests fail to meet SMYS, two (2) re-tests taken from each of two (2) different pipes within the same test unit shall be tested (a total of 4 tests). If all re-tests meet SMYS, the test unit is acceptable. If any of the re-tests fall below SMYS, the test unit shall be rejected.

509 Re-testing of failed pipes is not permitted.

510 If the test results are influenced by improper sampling, machining, preparation, treatment or testing, the test sample shall be replaced by a correctly prepared sample from the same pipe, and a new test performed.

511 If a test unit has been rejected after re-testing (I507 and I508 above), the Manufacturer may conduct re-heat treatment of the test unit or individual testing of all the remaining pipes in the test unit. If the total rejection of all the pipes within one test unit exceeds 15%, including the pipes failing the mandatory and/or confirmatory tests, the test unit shall be rejected.

512 In this situation, the Manufacturer shall investigate and report the reason for failure and shall change the manufacturing process if required. Re-qualification of the MPS is required if the agreed allowed variation of any parameter is exceeded.

SECTION 8

CONSTRUCTION - COMPONENTS AND PIPELINE ASSEMBLIES

A. General

A 100 Objective

101 This Section specifies requirements to the construction of the components as defined in Table 8-1 and pipeline assemblies, see Sec.1 C208.

A 200 Application

201 This section is applicable to pressure containing components listed in Table 8-1 used in the submarine pipeline system. Design of components shall be in accordance with Sec.5 F.

Table 8-1 Manufacture and testing of pipeline components and pipeline assemblies		
<i>Components</i>	<i>Requirements for manufacture and testing given in this section</i>	<i>Reference code and applicable class or designation ¹⁾</i>
Bends ²⁾	B300	ISO 15590-1, PSL 2 for non-H ₂ S and PSL 2S for H ₂ S service
Fittings ²⁾³⁾	B400	ISO 15590-2, Class C for non-sour and Class CS for sour service
Flanges ²⁾	B500	ISO 15590-3, Designation (L) for non-sour and designation (LS) for sour service
Valves ²⁾	B600	ISO 14723
Mechanical connectors ²⁾	B700	ASME VIII Div.2 / EN 13445 / PD5500 ⁴⁾
CP Isolation joints ²⁾	B800	ASME VIII Div.2 / EN 13445 / PD5500 ⁴⁾
Anchor flanges ²⁾	B900	See Table 5-15
Buckle and fracture arrestors	B1000	
Pig traps ²⁾	B1100	ASME VIII Div.2 / EN 13445 / PD5500 ⁴⁾
Repair clamps and repair couplings ²⁾	B1200	DNV-RP-F113 (API RP 2201 for hot taps) ⁴⁾
Pipeline assemblies	F	
<i>Notes</i>		
1) The listed reference codes only cover C-Mn steels, for other materials reference is given to this section.		
2) Supplementary requirements F, P, D or U are not applicable.		
3) Fittings include: Elbows, caps, tees, wyes, single or multiple extruded headers, reducers and transition sections.		
4) Not covered by specific reference code, however, these codes are listed as relevant codes.		

202 Materials selection for components shall be in accordance with Sec.6.

A 300 Systematic review

301 The overall requirements to systematic review in Sec.2 will for this section apply for the component manufacturers and imply:

- Review of this Section and evaluate if the requirements in the Purchase Order and of this standard can be met.
- Identify any possible threats, evaluate the possible consequences and define necessary remedial measures.

A 400 Quality assurance

401 Requirements for quality assurance are given in Sec.2 B500. Corresponding requirements for the material processing and the manufacture of components shall be specified.

B. Component Requirements

B 100 General

101 References to requirements are listed in Table 8-1.

102 In paragraphs of subsection B200 to B600, ISO references are given between slashes, e.g.: /Annex A/. The paragraph text shall be read as either additional or modified requirement to ISO 15590 / ISO 14723.

B 200 Component specification

201 A component specification reflecting the results of the materials selection (see Sec.6 B), and referring to this section of the offshore standard, shall be prepared by the Purchaser. The specification shall state any additional requirements to and/or deviations from this standard pertaining to materials, manufacture, fabrication and testing of linepipe. For components covered by ISO 15590, see Table 8-1, the component specification should preferably refer to the applicable ISO standard with necessary modifications in line with this section of DNV-OS-F101.

B 300 Induction bends – additional and modified requirements to ISO 15590-1

301 /Annex A/ The following additional requirements shall be stated in the MPS:

- the number and location of the pyrometers used (minimum two, located 120 to 180° apart) and the allowable temperature difference between them
- the centring tolerances for the coil
- the number of water nozzles and flow rate.

302 /9.1/ The chemical composition of C-Mn steel mother pipe, including the backing steel of clad mother pipe, shall be in agreement with the composition for the linepipe grades listed in Tables 7-3, 7-4, 7-20 or 7-21 in Sec.7. The maximum carbon equivalent (CE) of quenched and tempered or normalised C-Mn steel mother pipe (delivery condition N or Q, respectively) shall be according to Table 8-2. The carbon equivalent (P_{cm}) of thermo-mechanical formed or rolled C-Mn steel mother pipe (delivery condition M) shall be maximum 0.02 higher than as required in Table 7-4.

SMYS	CE ¹⁾ , max.
245	0.36
290	0.38
320	0.40
360	0.43
390	0.43
415	0.44
450	0.45
485	0.46
555	0.47
<i>Note</i>	
1) According to Table 7-3	

303 The chemical composition of mother pipe for CRA materials shall meet the applicable requirements for the relevant material type and grade given in Sec.7.

Mother pipe shall be subjected to NDT as required for linepipe in Sec.7, except NDT of mother pipe ends if the ends will be cut off during bend fabrication.

Induction bends shall not be produced from CRA lined steel pipe.

Guidance note:

Hot expanded mother pipe may experience dimensional instability after post bending heat treatment.

Bends may be made from spare sections of normal linepipe. It should be noted that linepipe, particularly pipe manufactured from TMCP plate, may not have adequate hardenability to achieve the required mechanical properties after induction bending and subsequent post bending heat treatment.

Mother pipe of CRA clad C-Mn steel should preferably be longitudinally welded pipe manufactured from roll bonded plate

---e-n-d---of---G-u-i-d-a-n-c-e---n-o-t-e---

304 All mother pipes shall be mill pressure tested in accordance with Sec.7 E, where Sec.7 E107 does not apply.

305 /9.2 and Table 1/ The following parameters shall be additional to or modification of the essential variables given in Table 8-2:

- *Heat of steel:* This essential variable shall be replaced by: Change in ladle analysis for C-Mn steels outside $\pm 0.02\% C$, $\pm 0.02 CE$ and/or ± 0.03 in P_{cm} , or any change in nominal chemical composition for CRA's.
- Any change in number and position of pyrometers used and in the allowable temperature difference between the pyrometers.
- Any change in the stated tolerances for coil centring.
- Any change in the number and size of cooling nozzles and flow rate or water pressure.

306 /9.4/ Heat treatment equipment and procedures shall be in accordance with D500.

307 /10.4.4.2/ Hardness shall be measured in Hardness Vickers.

308 /Table 2 and 10.4.3/ For bends from mother pipe with nominal wall thickness greater than 25 mm, additional CVN testing shall during MPQT be performed at mid thickness in the following locations:

- transition zone base metal (if applicable)
- bend extrados base metal
- bend intrados base metal
- bend weld metal.

Acceptance criteria for mechanical testing shall meet the requirements given in Table 7-5 or Table 7-11 as applicable. CVN test temperature shall be in accordance with Table 7-6.

309 /10.4.5/ Surface hardness testing using portable equipment shall be performed in accordance with Appendix B.

310 /10.4.6/ For metallographic evaluation of CRA or clad induction bends, the acceptance criteria shall be in accordance with in Sec.7 C400 and C500.

311 /10.5/ Additional NDT testing shall be performed in accordance with Appendix D, sub-section H as applicable.

Acceptance criteria for the additional testing shall be according Appendix D, sub-section H.

312 /10.6/ Ovality of cross sections shall be kept within the specified tolerances. The bend radius shall be as specified by the Purchaser, and large enough (e.g. 5× outer diameter) to allow passage of inspection vehicles when relevant.

Dimensional control shall include the following additional or modified tests and acceptance criteria:

- ID at bend ends (always measure ID) shall be within ± 3 mm
- out-of-roundness of bend ends shall be maximum 1.5% and maximum 3% for the body, unless stricter requirements in ISO 15590-1
- the included angle between the centrelines of the straight portions of the bend shall be within $\pm 0.75^\circ$
- identification of weld seam location, i.e. clock position, and
- end squareness shall be within $\pm 0.5^\circ$, maximum 3 mm.

313 /10.7/ Gauging shall be performed as specified in the Component specification, see Sec.6 C300.

314 /10.8/ Hydrostatic testing shall comply with Sec.5 B201 and performed in accordance with G100.

315 /12.0/ Marking requirements shall be specified to distinguish between bends manufactured and tested to the requirements above and unmodified ISO 15590-1 bends.

B 400 Fittings - additional requirements to ISO 15590-2

401 The following components shall be defined as fittings: Elbows, caps, tees, wyes, single or multiple extruded headers, reducers and transition sections.

402 /6.2/ Tees and headers shall be of the integral (non-welded) reinforcement type. Outlets should be extruded. Bars of barred tees and wyes shall not be welded directly to the high stress areas around the extrusion neck. It is recommended that the bars transverse to the flow direction are welded to a pup piece, and that the bars parallel to the flow direction are welded to the transverse bars only. If this is impractical, alternative designs shall be considered in order to avoid peak stresses at the bar ends.

403 /7/ The information required in Sec.6 C302 shall be provided.

404 /8/ The following additional information shall be provided:

The MPS should specify the following items, as applicable:

- a) For the starting material
 - delivery condition
 - chemical composition, and
 - NDT procedures for examination of starting materials.
- b) For fitting manufacture
 - NDT procedures
 - hydrostatic test procedures
 - dimensional control procedures
 - coating and protection procedures
 - handling, loading and shipping procedures, and
 - at-site installation recommendations.

For “one-off” fittings designed and manufactured for a specific purpose, the following additional information shall be provided:

- plan and process flow description/diagram
- order specific quality plan including supply of material and subcontracts, and
- manufacturing processes including process- and process control procedures.

405 /8.2/ Starting material shall be subject to 100% NDT at an appropriate stage of manufacture according to:

- C-Mn steel and duplex stainless steel pipe shall be tested as required in Sec.7 or App.D C200.
- Appendix D B200, for RT of welds in starting materials other than pipe
- Appendix D B300 or B400 as applicable, for UT of welds in starting materials other than pipe
- Appendix D D200, for C-Mn steel forgings
- Appendix D D300, for duplex stainless steel forgings
- Appendix D C200, for UT of plate material

with acceptance criteria according to the corresponding requirements of Appendix D.

Subject to agreement, equivalent NDT standards with regard to method and acceptance criteria may be applied.

406 /8.3.2/ Welding and repair welding shall be performed in accordance with qualified procedures meeting the requirements in Appendix C.

407 /8.3.3/ Heat treatment equipment and procedures shall be in accordance with D500.

408 /9.2/ Testing requirements shall be in accordance with E100.

409 /Table 2/ Inspection, testing and acceptance criteria shall be in accordance with Class C with the following additional requirements:

- the chemical composition for components shall be modified according to C200
- the chemical composition of duplex stainless steel materials shall be according to C300
- mechanical and hardness testing of weld seams shall be performed in accordance with Appendix B and acceptance criteria shall be in accordance with E200 and E300 as applicable
- surface hardness testing of fittings of Class CS shall be performed with acceptance criteria according to 9.4.4.2
- metallographic examination for welds and body of duplex stainless steel fittings shall be performed in accordance with Appendix B and with acceptance criteria according to E300
- HIC testing shall be performed on fittings in Class CS manufactured from rolled material as required in Table 8-4
- 25Cr duplex stainless steel fittings shall be corrosion tested as required in Table 8-4, and
- NDT of fitting bodies shall be performed according to B512.

410 /Table 3/ The extent of testing and examination shall comprise the following additional requirements:

- the test unit definition shall be amended to: Fitting or test piece of the same designation, starting material wall thickness, heat, manufacturing procedure specification and heat treatment batch
- surface hardness tests shall be performed on two fittings per test unit
- metallography of duplex stainless steel fittings with the largest thickness exceeding 25 mm shall be performed as one per test unit
- HIC testing shall be performed for qualification of the MPS for fittings in Class CS manufactured from rolled material, and
- 25Cr duplex stainless steel fittings shall be corrosion tested for qualification of the MPS, in accordance with Table 8-4.

411 /Table 2 and 9.5/ NDT of each completed fitting shall be performed in accordance with the Table 2, Class C with the following additional requirements:

- the body of fittings manufactured from plates and pipes shall be subject to 100% magnetic particle testing for C-Mn steels and 100% dye penetrant/eddy current testing for duplex stainless steel
- the extrusion area for tees and headers with adjoining pipe wall thickness ≥ 12 mm shall be subject to 100% volumetric ultrasonic and 100% magnetic particle testing for C-Mn steels and 100% volumetric ultrasonic and 100% dye penetrant/eddy current testing for duplex stainless steel
- the extrusion area for tees and headers with adjoining pipe wall thickness < 12 mm shall be subject to 100% magnetic particle testing for C-Mn steels and 100% dye penetrant/eddy current testing for duplex stainless steel
- overlay welds shall be tested 100%.

412 NDT shall be performed in accordance with Appendix D (as applicable):

- C400, for visual inspection
- D200, for C-Mn/low alloy steel forgings

- D300, for duplex stainless steel forgings
- C206 through 213, for UT of a 50 mm wide band inside ends/bevels
- C221, for MT of ends/bevels
- C222, for PT of ends/bevels
- B200, for RT of welds
- B300, for UT of welds in C-Mn/low alloy steel
- B400, for UT of welds in duplex stainless steel
- B500, for MT of welds in C-Mn/low alloy steel
- B600, for DP of welds in duplex stainless steel
- C300, for overlay welds
- D400, for visual inspection of forgings
- B800, for visual inspection of welds, and
- C500, for residual magnetism.

Acceptance criteria shall be according to the corresponding requirements of Appendix D.

413 /9.8/ Hydrostatic testing shall comply with Sec.5 B201 and performed in accordance with G100.

414 /11/ Marking requirements shall be specified to distinguish between fittings manufactured and tested to the requirements above and unmodified ISO 15590-2 fittings.

B 500 Flanges and flanged connections - additional requirements to ISO 15590-3

501 /7/ The following additional information shall be provided:

- required design life
- nominal diameters, D or ID, out of roundness and wall thickness for adjoining pipes including required tolerances
- dimensional requirements and tolerance if different from ISO 7005-1
- minimum design temperature (local)
- maximum design temperature (local)
- external loads and moments that will be transferred to the component from the connecting pipeline under installation and operation and any environmental loads (e.g. nominal longitudinal strain)
- material type and grade, delivery condition, chemical composition and mechanical properties at design temperature
- required testing
- corrosion resistant weld overlay.

502 /8/ Overlay welding shall be performed according to qualified welding procedures meeting the requirements of Appendix C.

503 /8.1/ The MPS shall be in accordance with D100.

504 /8.2 & Table 4/

- The chemical composition for flanges shall be modified according to C200.
- The chemical composition of duplex stainless steel materials shall be according to C300.

505 /8.4/ Heat treatment equipment and procedures shall be in accordance with D500.

506 /Table 3/ Mechanical testing shall be performed with the following additional requirements:

- Tensile, impact and through thickness hardness shall be performed once per test unit with the test unit defined as; Flanges of the same size, heat, manufacturing procedure specification and heat treatment batch.
- Surface hardness testing shall be performed once per test unit for flanges in class LS.
- Mechanical, hardness and corrosion testing of flanges shall be performed as required by E100, acceptance criteria to E200 or E300 as applicable.
- Metallographic examination for duplex stainless steel flanges shall be performed according to E100, with acceptance criteria according to E300.

507 /Table 5/ The impact test temperature for C-Mn steel and low alloy flanges shall be 10°C below the minimum design temperature for all thicknesses and categories.

508 /9.4.4/ Hardness indentation locations shall be according to Table 8-4.

509 /9.4.5/ Metallographic examination of duplex stainless steel shall be performed in accordance with Appendix B, with acceptance criteria according to Sec.7 C400.

510 /9.4.6 & 9.4.7/ Corrosion testing of duplex stainless steel shall be according to Table 8-4.

511 /9.5.4/ The extent of NDT shall be 100% magnetic particle testing of ferromagnetic materials and 100% liquid penetrant testing of non magnetic materials. A percentage test is not permitted.

512 /9.5.5/ 100% ultrasonic testing of the final 50 mm of each end of the flange shall be performed. 100% ultrasonic testing of the first 10 flanges of each type and size ordered. If no defects are found during the testing

of the first 10 flanges of each type and size ordered the extent of testing may be reduced to 10% of each size and type. If defects are found in any tested flange, all flanges of the same size, heat, manufacturing procedure specification and heat treatment batch shall be 100% tested.

All flanges shall be subject to 100% visual inspection.

513 NDT shall be performed in accordance with Appendix D or ISO (as applicable):

- Magnetic particle testing shall be performed in accordance with App.D D200 or ISO 13664
- Liquid penetrant testing shall be performed in accordance with App.D D300 or ISO 12095
- Ultrasonic testing of C-Mn/low alloy steel forgings shall be performed in accordance with App.D D200
- Ultrasonic testing of duplex stainless steel forgings shall be performed in accordance with App.D D300
- Testing of overlay welds shall be performed in accordance with App.D C300
- Visual examination shall be in accordance with App.D D400

Acceptance criteria for forgings shall be in accordance with the corresponding requirements of App.D D500 and for overlay welds only, in accordance with App.D C600.

Subject to agreement, equivalent NDT standards with regard to method and acceptance criteria may be applied.

514 /9.6/ For flanges with specified dimensions and tolerances different from ISO 7005-1, these specified requirements shall be met.

515 /9.7/ Hydrostatic testing shall comply with Sec.5 B201 and performed in accordance with G100.

516 /9.9/ Repair welding of flange bodies is not permitted.

517 /11/ Marking requirements shall be specified to distinguish between flanges manufactured and tested to the requirements above and unmodified ISO 15590-3 flanges.

Flanged connections

518 Sealing rings shall be compatible with the finish and surface roughness of the flange contact faces.

519 Sealing rings shall be capable of withstanding the maximum pressure to which they could be subjected, as well as installation forces if flanges are laid in-line with the pipeline. Sealing rings for flanges shall be made from metallic materials that are resistant to the fluid to be transported in the pipeline system. Mechanical properties shall be maintained at the anticipated in service pressures and temperatures.

520 Bolts shall meet the requirements given in C500.

521 For the use of ANSI, RTJ and orifice flanges it must be ensured that the flanges are suitable for subsea use, e.g. by means of materials compatibility and use of vent holes to avoid water trapping and pressure build up in the groove area for gaskets.

B 600 Valves – additional requirements to ISO 14723

601 /Annex B/ The following additional information shall be provided:

- design standard
- required design life
- minimum design temperature (local)
- maximum design temperature (local)
- design pressure (local)
- water depth, and
- weld overlay, corrosion resistant and/or wear resistant.

Manufacturing procedure specification

602 A manufacturing procedure specification in accordance with D100 shall be documented.

603 /7.1, 7.4 and 7.7/ Materials shall be specified to meet the requirements given in subsection C.

604 /7.5/ The impact test temperature shall be 10°C below the minimum design temperature

605 /7.6/ Bolting shall meet the requirements of C500.

606 /8/ Welding shall be performed according to qualified welding procedures meeting the requirements of Appendix C.

607 /9.4/ The extent, method and type of NDT of C-Mn/low alloy steels shall be in accordance with ISO 14723, Annex E, QL 2 requirements.

The extent and type of NDT of duplex stainless steels shall be in accordance with ISO 14723, Annex E, QL 2 requirements. Methods shall be according to Appendix D of this standard.

The extent and type of NDT of weld overlay shall be in accordance with ISO 14723, Annex E, QL 2 requirements. the method shall be according to Appendix D.

Acceptance criteria for NDT shall be in accordance with ISO 14723, Annex E with the following amendments:

For UT 2, VT 2 and VT 3 the acceptance criteria shall be in accordance with Appendix D of this standard.

608 /9.5/ Repair welding of forgings is not permitted.

609 /10.2/ Hydrostatic shell tests shall be performed in accordance with ISO 14723, Clause 10, or according to specified requirements in compliance with Sec.5 B201.

610 /11/ Marking requirements shall be specified to distinguish between valves manufactured and tested to the requirements above and unmodified ISO 14723 valves.

611 Valves with requirements for fire durability shall be qualified by applicable fire tests. Refer to API 6FA and BS 6755 Part 2 for test procedures.

B 700 Mechanical connectors

701 These requirements apply to manufacture and testing of end connections such as hub and clamp connections connecting a pipeline to other installations.

702 Bolting shall meet the requirements of C500.

703 End connections shall be forged.

704 The extent of NDT shall be:

- 100% magnetic particle testing of ferromagnetic materials and 100% liquid penetrant testing of non magnetic materials.
- 100% ultrasonic testing of forgings and castings
- 100% RT of critical areas of castings
- 100% ultrasonic or radiographic testing of welds
- 100% magnetic particle testing / liquid penetrant testing of welds
- 100% visual inspection

NDT shall be performed in accordance with Appendix D (as applicable):

- C400, for visual inspection
- D200, for C-Mn/low alloy steel forgings
- D300, for duplex stainless steel forgings
- E200, for C-Mn/low alloy steel castings
- E300, for duplex stainless steel castings
- E400, for RT of castings
- C221, for MT of ends/bevels
- C222, for DP of ends/bevels
- B200, for RT of welds
- B300, for UT of welds in C-Mn/low alloy steel
- B400, for UT of welds in duplex stainless steel
- B500, for MT of welds in C-Mn/low alloy steel
- B600, for DP of welds in duplex stainless steel
- C300, for overlay welds
- D400, for visual inspection of forgings
- E500, for visual examination of castings
- B800, for visual inspection of welds
- C500, for residual magnetism.

Acceptance criteria shall be according to the corresponding requirements of Appendix D.

705 Hydrostatic testing shall comply with Sec.5 B201 and performed in accordance with G100.

B 800 CP Isolation joints

801 These requirements apply to manufacture and testing of boltless, monolithic coupling type of isolation joints for onshore applications.

802 CP isolation joints shall be manufactured from forgings.

803 Isolation joints shall be protected from electrical high current high voltage from welding and lightning etc. in the construction period. If high voltage surge protection is not provided in the construction period isolation joints shall be fitted with a temporary short-circuit cable clearly tagged with the instruction “not to be removed until installation of permanent high voltage surge protection”.

804 For manufacturers without previous experience in the design, manufacture and testing of isolation joints, one joint should be manufactured and destructively tested for the purpose of qualifying the design and materials of the joint.

The qualification programme should as a minimum contain the following elements:

- bending to maximum design bending moment
- tension to maximum design tension
- pressure testing to 1.5 times the design pressure

- pressure cycling from minimum to maximum design pressure 10 times at both minimum and maximum design temperature.

Before and after testing the resistance and electrical leakage tests should show the same and stable values.

In addition, after full tests the joint should be cut longitudinally into sections to confirm the integrity of the insulation and fill materials and the condition of the O-ring seals.

805 Isolation joint shall be forged close to the final shape (if applicable). Machining of up to 10% of the local wall thickness at the outside of the component is allowed.

806 The extent of NDT shall be:

- 100% magnetic particle testing of ferromagnetic materials and 100% liquid penetrant testing of non magnetic materials
- 100% ultrasonic testing of forgings
- 100% ultrasonic or radiographic testing of welds
- 100% magnetic particle testing / liquid penetrant testing of welds
- 100% visual inspection.

NDT shall be performed in accordance with Appendix D (as applicable):

- C400, for visual inspection
- D200, for C-Mn/low alloy steel forgings
- D300, for duplex stainless steel forgings
- C221, for MT of ends/bevels
- C222, for DP of ends/bevels
- B200, for RT of welds
- B300, for UT of welds in C-Mn/low alloy steel
- B400, for UT of welds in duplex stainless steel
- B500, for MT of welds in C-Mn/low alloy steel
- B600, for DP of welds in duplex stainless steel
- C300, for overlay welds
- D400, for visual inspection of forgings
- B800, for visual inspection of welds, and
- C500, for residual magnetism.

Acceptance criteria shall be according to the corresponding requirements of Appendix D.

807 Prior to hydrostatic testing, hydraulic fatigue test and the combined pressure-bending test / electrical leakage tests shall be performed and the results recorded.

808 Hydrostatic strength test of each isolation joint shall be performed with a test pressure 1.5 times the design pressure, unless otherwise specified, and to the specified holding time in general accordance with G100.

809 Hydraulic fatigue testing of each isolation joint shall be performed. The test shall consist of 40 consecutive cycles with the pressure changed from 10 barg to 85 percent of the hydrostatic test pressure. At the completion of the test cycles the pressure shall be increased to the hydrostatic test pressure and maintained for 30 minutes. For acceptance criterion, see G114.

810 One isolation joint per size/design pressure shall also be tested to meet the specified bending moment requirements. The joint shall be pressurised to the specified hydrostatic test pressure and simultaneously be subjected to an external 4 point bending load sufficient to induce a total (bending plus axial pressure effect) longitudinal stress of 90% of SMYS in the adjoining pup pieces. The test duration shall be 2 hours. The acceptance criteria are no water leakage or permanent distortion.

811 After hydrostatic testing, all isolation joints shall be leak tested with air or nitrogen. The joints shall be leak tested at 10 barg for 10 minutes. The tightness shall be checked by immersion or with a frothing agent. The acceptance criterion is: no leakage.

812 The FAT shall be performed according to the accepted FAT programme. The FAT shall consist of:

- dielectric testing
- electrical resistance testing
- electrical leakage tests.

813 Prior to FAT isolation joints shall be stored for 48 hours at an ambient temperature between 20 and 25°C and a relative humidity of max. 93%.

814 Dielectric testing shall be performed by applying an AC sinusoidal current with a frequency of 50 - 60 Hz to the joint. The current shall be applied gradually, starting from an initial value not exceeding 1.2kV increasing to 5.0kV in a time not longer than 10 seconds and shall be maintained at peak value for 60 seconds. The test is acceptable if no breakdown of the isolation or surface arcing occurs during the test and a maximum leakage of current across the isolation of 1 mA.

815 Electrical resistance testing shall be carried out at 1000 V DC. The test is acceptable if the electrical resistance is minimum 25 MOhm.

816 Electrical leakage tests shall be performed to assess any changes which may take place within a joint after hydrostatic testing, hydraulic fatigue test and the combined pressure-bending test. No significant changes in electrical leakage shall be accepted.

B 900 Anchor flanges

901 Anchor flanges shall be forged.

902 The extent of NDT shall be:

- 100% magnetic particle testing of ferromagnetic materials and 100% liquid penetrant testing of non magnetic materials
- 100% ultrasonic testing of forgings
- 100% ultrasonic or radiographic testing of welds
- 100% magnetic particle testing / liquid penetrant testing of welds
- 100% visual inspection

NDT shall be performed in accordance with Appendix D (as applicable):

- C400, for visual inspection
- D200, for C-Mn/low alloy steel forgings
- D300, for duplex stainless steel forgings
- C221, for MT of ends/bevels
- C222, for DP of ends/bevels
- B200, for RT of welds
- B300, for UT of welds in C-Mn/low alloy steel
- B400, for UT of welds in duplex stainless steel
- B500, for MT of welds in C-Mn/low alloy steel
- B600, for DP of welds in duplex stainless steel
- D400, for visual inspection of forgings
- B800, for visual inspection of welds, and
- C500, for residual magnetism.

Acceptance criteria shall be according to the corresponding requirements of Appendix D.

903 Hydrostatic testing shall comply with Sec.5 B201 and performed in accordance with G100.

B 1000 Buckle- and fracture arrestors

1001 The material for buckle and fracture arrestors and manufacture, inspection and testing shall be in accordance with Subsections C, D and E (if forged/cast), or Sec.7 (if linepipe).

B 1100 Pig traps

1101 Materials shall comply with the requirements of the design code or with the requirements of this section, if more stringent.

1102 Testing and acceptance criteria for qualification of welding procedures shall comply with the requirements of the design code or with the requirements of Appendix C, if more stringent.

Essential variables for welding procedures shall comply with the requirements of the design code.

Production welding shall comply with the requirements in Appendix C.

1103 The extent, methods and acceptance criteria for NDT shall comply with the requirements of the design code. In addition the requirements of Appendix D, Subsection A and B100 shall apply.

1104 Hydrostatic testing shall comply with the requirements of the design code and Sec.5 B201 and G100.

B 1200 Repair clamps and repair couplings

1201 Repair clamps and repair couplings to be installed according to DNV-RP-F113 shall be manufactured and tested in accordance with this section and based on materials selection according to Sec.6.

1202 Hydrostatic testing shall comply with Sec.5 B201 and performed in accordance with G100.

C. Materials

C 100 General

101 The materials used shall comply with internationally recognised standards, provided that such standards have acceptable equivalence to the requirements given in Sec.7 and this section. Modification of the chemical

composition given in such standards may be necessary to obtain a sufficient combination of weldability, hardenability, strength, ductility, toughness, and corrosion resistance.

102 Sampling for mechanical and corrosion testing shall be performed after final heat treatment, i.e. in the final condition. The testing shall be performed in accordance with Appendix B and E100.

C 200 C-Mn and low alloy steel forgings and castings

201 These requirements are applicable to C-Mn and low alloy steel forgings and castings with SMYS ≤ 555 MPa. Use of higher strength materials shall be subject to agreement.

202 All steels shall be made by an electric or one of the basic oxygen processes. C-Mn steel shall be fully killed and made to a fine grain practice.

203 The chemical composition for hot-formed, cast and forged components shall be in accordance with recognised international standards. The chemical composition shall be selected to ensure an acceptable balance between sufficient hardenability and weldability.

204 For materials to be quenched and tempered, a hardenability assessment shall be performed to ensure that the required mechanical properties can be met.

205 For C-Mn steels the maximum Carbon Equivalent (CE) shall not exceed 0.50, when calculated in accordance with:

$$CE = C + \frac{Mn}{6} + \frac{Cr + Mo + V}{5} + \frac{Cu + Ni}{15} \quad (8.1)$$

206 Acceptance criteria for tensile, hardness and Charpy V-notch impact properties are given in E200.

207 Forgings shall be delivered in normalised or quenched and tempered condition.

208 Castings shall be delivered in homogenised, normalised and stress relieved or homogenised, quenched and tempered condition.

209 For C-Mn and low alloy materials delivered in the quenched and tempered condition, the minimum tempering temperature shall be 610°C when PWHT will be applied, unless otherwise specified.

C 300 Duplex stainless steel, forgings and castings

301 All requirements with regard to chemical composition for 22Cr and 25Cr duplex stainless steel shall be in accordance with Sec.7 C400.

302 Acceptance criteria for tensile, hardness, Charpy V-notch impact properties and corrosion tests are given in E300.

303 Duplex stainless steel castings and forgings shall be delivered in the solution annealed and water quenched condition.

C 400 Pipe and plate material

401 Pipe and plate material shall meet the requirements in Sec.7.

402 For welded pipe it shall be assured that the mechanical properties of the material and longitudinal welds will not be affected by any heat treatment performed during manufacture of components.

403 In case PWHT is required, the mechanical testing should be conducted after simulated heat treatment.

C 500 Bolting materials

501 In general, bolting material selection shall be in line with the applicable design code supplemented with Sec.6 B600 and C400, with limitations and additional requirements as given in C502 to C510.

502 For components based on ASME design codes, carbon and low alloy steel bolts and nuts for pressure containing and main structural applications shall be selected in accordance with Table 8-3.

For components based on other design codes, equivalent carbon and low alloy steel bolts in line with the design code shall be selected.

Guidance note:

The bolting materials listed in Table 8-3 may be used in combination with other design codes than ASME design codes if properly considered by the designer. This shall include assessment of allowable utilisation and derating for elevated temperature applications, if relevant. Applicable ASME design codes list pre-defined allowable stresses, which are not necessarily based on SMYS and SMTS, while other design codes define utilisation based on safety factors on SMYS and SMTS. This shall be considered when mixing ASTM bolting materials with other codes than ASTM design codes.

---e-n-d---of---G-u-i-d-a-n-c-e---n-o-t-e---

<i>Temperature range (°C)</i>	<i>Bolt</i>	<i>Nut</i>	<i>Size range</i>
-100 to + 400	ASTM A320, Grade L7	ASTM A194, Grade 4/S3/S4/S5 or Grade 7/S3/S4/S5	< 65 mm
-100 to + 400	ASTM A320, Grade L7M	ASTM A194, Grade 7M/S3/S4/S5	< 65 mm
-100 to + 400	ASTM A320, Grade L43	ASTM A194, Grade 7/S3/S4/S5	< 100 mm

503 Carbon and low alloy steel bolting materials shall be Charpy-V impact tested. The bolting materials shall meet the requirements for the bolted connection, i.e. the materials to be bolted. See E105 and E201 for test temperature and acceptance criteria.

504 Stainless steel bolts according to ASTM A193/A320 grade B8M (type AISI 316) are applicable but require efficient cathodic protection for subsea use.

505 Ni-based bolts according to ASTM B446 type UNS N06625 or other Ni-based solution hardening alloys with equivalent or higher PRE are acceptable. However, these bolting materials shall only be used in the solution annealed condition, or cold worked to SMYS 720 MPa maximum.

506 Maximum hardness shall not exceed 35 HRC for carbon and low alloy steels, in addition to solution annealed or cold-worked type AISI 316 or any other cold-worked austenitic stainless steel (only applicable if the bolts will be exposed to cathodic protection).

507 Restrictions for H₂S service (also referred to as sour service) according to ISO 15156 shall apply when applicable.

508 The hardness of bolts and nuts shall be verified for each lot (i.e. bolts of the same size and material, from each heat of steel and heat treatment batch) and be traceable back to heat number.

Guidance note:

In order to ensure acceptable traceability, several Companies require higher frequency for hardness testing than one per lot for verification of subsea fasteners. The party installing the bolts should also consider to perform random testing of bolt properties.

---e-n-d---of---G-u-i-d-a-n-c-e---n-o-t-e---

509 For acid cleaned and/or electrolytically plated bolts and nuts, baking at 200°C for a minimum of 2 hours is required in order to prevent hydrogen embrittlement.

510 Only unused bolting materials shall be applied.

C 600 H₂S service

601 For components in pipeline systems to be used for fluids containing hydrogen sulphide and defined as H₂S service according to ISO 15156, all requirements to chemical composition, maximum hardness, and manufacturing and fabrication procedures given in the above standard shall apply.

602 The sulphur content of C-Mn and low alloy steel forgings and castings shall not exceed 0.010%.

603 Pipe and plate material used for fabrication of components shall meet the requirements given in Sec.7 I100.

D. Manufacture

D 100 Manufacturing procedure specification (MPS)

101 The requirements of this subsection are not applicable to induction bends and fittings that shall be manufactured in accordance with B300 and B400

102 Components shall be manufactured in accordance with a documented and approved MPS.

103 The MPS shall demonstrate how the fabrication will be performed and verified through the proposed fabrication steps. The MPS shall address all factors which influence the quality and reliability of production. All main fabrication steps from control of received material to shipment of the finished product(s), including all examination and check points, shall be covered in detail. References to the procedures and acceptance criteria established for the execution of all steps shall be included.

104 The MPS should be project specific and specify the following items as applicable:

- Starting materials
- manufacturer

- steel making process
- steel grade
- product form, delivery condition
- chemical composition
- welding procedure specification (WPS)
- NDT procedures.
- Manufacturing
 - supply of material and subcontracts
 - manufacturing processes including process- and process control procedures
 - welding procedures
 - heat treatment procedures
 - NDT procedures
 - list of specified mechanical and corrosion testing
 - hydrostatic test procedures
 - functional test procedures
 - dimensional control procedures
 - FAT procedures
 - marking, coating and protection procedures
 - handling, loading and shipping procedures
 - at-site installation recommendations.

For “one-off” components and other components designed and manufactured for a specific purpose, the following additional information shall be provided:

- plan and process flow description/diagram
- order specific quality plan including supply of material and subcontracts
- manufacturing processes including process- and process control procedures.

D 200 Forging

201 Forging shall be performed in compliance with the accepted MPS. Each forged product shall be hot worked as far as practicable, to the final size with a minimum reduction ratio of 4:1.

202 The work piece shall be heated in a furnace to the required working temperature.

203 The working temperature shall be monitored during the forging process.

204 If the temperature falls below the working temperature the work piece shall be returned to the furnace and re-heated before resuming forging.

205 The identity and traceability of each work piece shall be maintained during the forging process.

206 Weld repair of forgings is not permitted.

D 300 Casting

301 Casting shall be performed in general compliance with ASTM A352.

302 A casting shall be made from a single heat and as a single unit.

303 Castings may be repaired by grinding to a depth of maximum 10% of the actual wall thickness, provided that the wall thickness in no place is below the minimum designed wall thickness. The ground areas shall merge smoothly with the surrounding material.

304 Defects deeper than those allowed by D303 may be repaired by welding. The maximum extent of repair welding should not exceed 20% of the total surface area. Excavations for welding shall be ground smooth and uniform and shall be suitably shaped to allow good access for welding.

305 All repair welding shall be performed by qualified welders and according to qualified welding procedures.

D 400 Hot forming

401 Hot forming shall be performed according to an agreed procedure containing:

- sequence of operations
- heating equipment
- material designation
- pipe diameter, wall thickness and bend radius
- heating/cooling rates
- maximum and minimum temperature during forming operation
- temperature maintenance/control
- recording equipment
- position of the longitudinal seam

- methods for avoiding local thinning
- post bending heat treatment (duplex stainless steel: full solution annealing and water quenching)
- hydrostatic testing procedure
- NDT procedures
- dimensional control procedures.

402 Hot forming of C-Mn and low alloy steel, including extrusion of branches, shall be performed below 1100°C. If microalloying elements have been added to prevent grain growth (e.g. Ti), the hot forming temperature may be increased to 1150°C. The temperature shall be monitored. The component shall be allowed to cool in still air.

403 For duplex stainless steel material, the hot forming shall be conducted between 1000 and 1150°C.

D 500 Heat treatment

501 Heat treatment procedures for furnace heat treatment shall as a minimum contain the following information:

- heating facilities
- furnace
- insulation (if applicable)
- measuring and recording equipment, both for furnace control and recording of component temperature
- calibration intervals for furnace temperature stability and uniformity and all thermocouples
- fixtures and loading conditions
- heating and cooling rates
- temperature gradients
- soaking temperature range and time
- maximum time required for moving the component from the furnace to the quench tank (if applicable)
- cooling rates (conditions)
- type of quenchant (if applicable)
- start and end maximum temperature of the quenchant (if applicable).

502 If PWHT in an enclosed furnace is not practical, local PWHT shall be performed according to Appendix C, G400.

503 The heat treatment equipment shall be calibrated at least once a year in order to ensure acceptable temperature stability and uniformity. The uniformity test shall be conducted in accordance with a recognised standard (e.g. ASTM A991). The temperature stability and uniformity throughout the furnace volume shall be within $\pm 10^\circ\text{C}$.

504 Whenever practical, thermocouple(s) should be attached to one of the components during the heat treatment cycle.

505 Components should be rough machined to near final dimensions prior to heat treatment. This is particularly important for large thickness components.

Guidance note:

The extent and amount of machining of forgings and castings prior to heat treatment should take into account the requirements for machining to flat or cylindrical shapes for ultrasonic examination. See also Appendix D.

---e-n-d---of---G-u-i-d-a-n-c-e---n-o-t-e---

506 For components that shall be water quenched, the time from the components leave the furnace until being immersed in the quenchant shall not exceed 90 seconds for low alloy steel, and 60 seconds for duplex stainless steels.

507 The volume of quenchant shall be sufficient and shall be heavily agitated, preferably by cross flow to ensure adequate cooling rate. The maximum temperature of the quenchant shall never exceed 40°C. Temperature measurements of the quenchant shall be performed.

508 The hardness of the accessible surfaces of the component shall be tested. The hardness for C-Mn or low alloy steels and duplex stainless steels shall be in accordance with E200 and E300, respectively.

D 600 Welding

601 Welding and repair welding shall be performed in accordance with qualified procedures meeting the requirements of Appendix C.

D 700 NDT

701 NDT shall be performed in accordance with Appendix D.

E. Mechanical and Corrosion Testing

E 100 General testing requirements

101 Testing of mechanical properties after hot forming, casting or forging shall be performed on material taken from one prolongation or component from each test unit (i.e. components of the same size and material, from each heat and heat treatment batch) shall be tested as given in Table 8-4, as applicable.

102 All mechanical testing shall be conducted after final heat treatment.

103 If agreed, separate test coupons may be allowed providing they are heat treated together with the material they represent, and the material thickness, forging reduction, and mass are representative of the actual component.

104 A simulated heat treatment of the test piece shall be performed if welds between the component and other items such as linepipe are to be PWHT at a later stage or if any other heat treatment is intended.

105 The CVN test temperature shall be 10°C below the minimum design temperature.

106 Sampling for mechanical and corrosion testing shall be performed after final heat treatment, i.e. in the final condition. The testing shall be performed in accordance with Appendix B.

107 A sketch indicating the final shape of the component and the location of all specimens for mechanical testing shall be issued for review and acceptance prior to start of production.

108 For 25Cr duplex stainless steels corrosion testing according to ASTM G48 shall be performed in order to confirm that the applied manufacturing procedure ensures acceptable microstructure. Testing shall be performed in accordance with Appendix B at 50°C. The test period shall be 24 hours.

E 200 Acceptance criteria for C-Mn and low alloy steels

201 Tensile, hardness and Charpy V-notch impact properties shall meet the requirements for linepipe with equal SMYS as given in Sec.7 B400.

202 The hardness for components intended for non- H₂S service shall not exceed 300 HV10. For components intended for H₂S service the hardness shall be according to Sec.7 I100.

Table 8-4 Number, orientation, and location of test specimens per tested component		
<i>Type of test</i>	<i>No. of tests</i>	<i>Test location, e.g. as shown in Figure 1^{1, 2)}</i>
Tensile test for components having maximum section thickness $T \leq 50$ mm	3	One specimen in tangential direction from the thickest section 1/2T below the internal surface One mid thickness specimen in both tangential and axial direction from the area with highest utilisation (after final machining), e.g. the weld neck area ³⁾
Tensile test for components having maximum section thickness $T > 50$ mm	3	One specimen in tangential direction from the thickest section 1/4T below the internal surface One mid thickness specimen in both tangential and axial direction from the area with highest utilisation (after final machining), e.g. the weld neck area ³⁾
CVN impact testing, axial and tangential specimens for components having maximum section thickness $T \leq 50$ mm ^{4, 5)}	3 sets	One set in tangential direction from the thickest section 1/2T. One mid thickness specimen in both tangential and axial direction from the area with highest utilisation (after final machining), e.g. the weld neck area ³⁾
CVN impact testing, axial and tangential specimens for components having maximum section thickness $T > 50$ mm ^{4, 5)}	3 sets	One specimen in tangential direction from the thickest section 1/4T below the internal surface One mid thickness specimen in both tangential and axial direction from the area with highest utilisation (after final machining), e.g. the weld neck area ³⁾
CVN impact testing of the thickest section of the component for section thickness ≥ 30 mm ^{4, 5, 6)}	1 set	One set in the tangential direction 2 mm below the internal surface
Metallographic sample ⁷⁾	2 or 3	As for the CVN impact testing sets

Table 8-4 Number, orientation, and location of test specimens per tested component (Continued)		
<i>Type of test</i>	<i>No. of tests</i>	<i>Test location, e.g. as shown in Figure 1 ^{1, 2)}</i>
Hardness testing ⁸⁾	3	As for the CVN impact testing sets
HIC and SSC test ⁹⁾	1	In accordance with ISO 15156
ASTM G48 ¹⁰⁾	1	See E108

- Notes*
- 1) For welded components, the testing shall also include testing of the welds in accordance with Appendix C.
 - 2) Internal and external surface refers to the surfaces of the finished component.
 - 3) For Tees and Wyes both main run and branch weld necks shall be tested.
 - 4) For CVN impact testing one set consists of three specimens.
 - 5) The notch shall be perpendicular to the component's surface.
 - 6) Only applicable to C-Mn and low alloy steel. The section thickness is in the radial direction in the as-heat treated condition.
 - 7) 2 samples for section thickness < 30 mm (only one sample from mid thickness location) and 3 samples for section thickness ≥ 30 mm.
 - 8) A minimum of 3 hardness measurements shall be taken on each sample.
 - 9) Only applicable for rolled C-Mn steels not meeting the requirements in C600.
 - 10) Only applicable for 25Cr duplex steels.

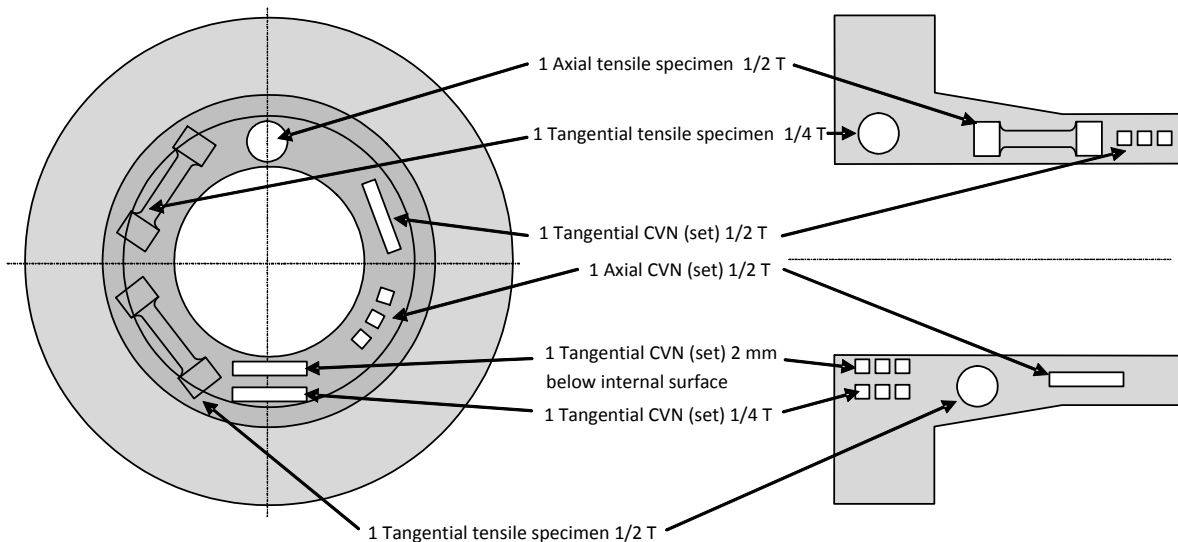

Figure 1
Location of tensile and CVN specimens, component with section thickness ≥ 25 mm

203 Specimens for hardness testing shall be examined, prior to testing, at a magnification of not less than X100. Grain-size measurement shall be performed in accordance with ASTM E112. The type of microstructure and actual grain size shall be recorded on the materials testing report.

E 300 Acceptance criteria for duplex stainless steels

301 Tensile, hardness and Charpy V-notch impact properties shall meet the requirements for linepipe as given in Sec.7 C400.

302 The metallographic samples shall comply with the requirements of Sec.7 C400.

303 For ASTM G48 testing the acceptance criteria is: maximum allowable weight loss 4.0 g/m².

F. Pipeline Assemblies

F 100 General

101 This Subsection is applicable for the fabrication of pipe strings (stalks) for reeling and towing, rigid risers, spools and expansion loops.

102 The fabrication shall be performed according to a specification giving the requirements for fabrication methods, procedures, extent of testing, acceptance criteria and required documentation. The specification shall be subject to agreement prior to start of production.

F 200 Materials

201 Linepipe shall comply with the requirements, including supplementary requirements (as applicable) given in Sec.7.

202 Induction bends shall comply with the requirements in this section, see B300.

203 Forged and cast material shall as a minimum meet the requirements given in this section.

F 300 Fabrication procedures, planning and mobilisation

301 The construction site shall have quality assurance and systems, see Sec.10 A500.

302 The construction site shall establish the following:

- organisation and communication
- health, safety and environment manual
- emergency preparedness
- security plan including ISPS.

303 The construction site shall establish the following:

- material handling and storage (see F400).
- material receipt, identification and tracking (see F500)
- maintenance system.

304 All personnel shall be familiarized with the operation to be performed at the fabrication site. More detailed familiarization shall be performed for personnel specific work tasks.

305 Personnel involved in critical operations shall participate in a risk assessment for the specific operation.

306 Equipment needed for the operations at the fabrication site shall be defined and mobilised.

307 Before production commences, the fabricator shall prepare a manufacture procedure specification (MPS). The MPS shall be issued for review and acceptance prior to start of fabrication.

308 The MPS shall demonstrate how the fabrication will be performed and verified through the proposed fabrication steps. The MPS shall address all factors which influence the quality and reliability of production. All main fabrication steps from control of received material to shipment of the finished product(s), including all examination and check points, shall be covered in detail. References to the procedures and acceptance criteria established for the execution of all steps shall be included.

Guidance note:

The MPS will as a minimum typically contain the following information:

- fabrication plan(s) and process flow description/diagram
- supply of material, i.e. manufacturer and manufacturing location of material
- fabrication process procedures
- dimensional and weight control procedures
- welding procedures including repair
- heat treatment procedures
- NDT procedures
- coating procedures including repair and field joint coating
- marking and protection procedures and
- reeling procedures
- stalk drawings
- handling, lifting, loading and shipping procedures.
- cleaning and gauging of pipes
- pressure test procedures, if applicable.

---e-n-d---of---G-u-i-d-a-n-c-e---n-o-t-e---

309 Due consideration shall be given to the access and time required for adequate inspection and testing as fabrication proceeds.

310 Due consideration during fabrication shall be given to the control of weight and buoyancy distribution of pipe strings for towing.

F 400 Linepipe temporary storage and transportation

401 Temporary storage of pipes, both single joints or several joints, shall consider potential corrosion damage. Corrosion damage may affect quality of NDT and pipeline integrity.

402 It shall be documented that storage facilities have the sufficient foundation for the weight of the pipes. Each pipe joint and pipe stack shall withstand relevant weight and environmental loading (e.g. wind, waves, earth quakes). Drainage of water shall be ensured. Potential icing shall be considered and appropriate counter-

active measures taken where found necessary.

403 Transportation and lifting of pipe joints shall be conducted safely to avoid damage to personnel, equipment and pipe joints. The equipment used for transportation and lifting shall not impose damage to the pipe joints.

404 Acceptable stacking heights shall be established and documented for temporary storage and transportation.

F 500 Material receipt, identification and tracking

501 All material shall be inspected for damage upon arrival. Quantities and identification of the material shall be verified. Damaged items shall be clearly marked, segregated and disposed of properly.

502 A system for ensuring correct traceability to the material shall be established. The identification of material shall be preserved during handling, storage and for all fabrication activities.

503 A pipe tracking system shall be used to maintain records of weld numbers, NDT records, pipe numbers, pipe lengths, bends, cumulative length, weight, anode installation, in-line assemblies and repair numbers. The system shall be capable of detecting duplicate records.

504 Pipes shall be inspected for loose material, debris, and other contamination, and shall be cleaned both internally and at the pipe ends before being added to the assembly. The cleaning method shall not cause damage to any internal coating.

505 The pipeline ends shall be protected against ingress of dust, water or any other material after cleaning and prior to being added to the assembly.

506 All debris caused by the welding shall be removed from the inside of the pipeline.

507 The individual pipes of pipe strings shall be marked in accordance with the established pipe tracking system using a suitable marine paint. The location, size and colour of the marking shall be suitable for reading by ROV during installation. In case installation of in-line assemblies or piggy back cables, it may be required to mark a band on top of the pipe string to verify if any rotation has occurred.

F 600 Hydrostatic testing

601 Hydrostatic testing shall comply with Sec.5 B201 and performed in accordance with G100.

F 700 Welding and NDT

701 Requirements for welding processes, welding procedure qualification, execution of welding and welding personnel are given in Appendix C.

702 Requirements for mechanical and corrosion testing for qualification of welding procedures are given in Appendix B.

703 Requirements for methods, equipment, procedures, acceptance criteria and the qualification and certification of personnel for visual examination and non-destructive testing (NDT) are given in Appendix D. Selection of non-destructive methods shall consider the requirements in Appendix D, A400.

704 Requirements to automated ultrasonic testing (AUT) are given in Appendix E.

705 Members to be welded shall be brought into correct alignment and held in position by clamps, other suitable devices, or tack welds, until welding has progressed to a stage where the holding devices or tack welds can be removed without danger of distortion, shrinkage or cracking. Suitable allowances shall be made for distortion and shrinkage where appropriate.

706 The fabrication and welding sequence shall be such that the amount of shrinkage, distortion and residual stress is minimised.

707 For production testing, see App.C, G526 to 532.

708 The extent of NDT for installation girth welds shall be 100% ultrasonic or radiographic testing. Radiographic testing should be supplemented with ultrasonic testing in order to enhance the probability of detection and/or characterisation/sizing of defects.

709 All welds shall be subject to 100% visual inspection.

710 For wall thickness > 25 mm, automated ultrasonic testing should be used.

711 Ultrasonic testing (UT) or automated ultrasonic testing (AUT) shall be used in the following cases:

- whenever sizing of flaw height and/or determination of the flaw depth is required (ref. Sec.5 D902).
- 100% lamination checks of a 50 mm wide band at ends of cut pipe.

712 When radiographic testing is the primary NDT method UT or AUT shall be used in the following cases:

- For the first 10 welds for welding processes with high potential for non-fusion type defects, when starting installation or when resuming production after suspension of welding
- to supplement radiographic testing for unfavourable groove configurations

- for wall thickness above 25 mm:
 - to provide additional random local spot checks during installation
 - to supplement radiographic testing to aid in characterising and sizing of ambiguous indications.

713 If UT reveals defects not discovered by radiography, the extent of UT shall be 100% for the next 10 welds. If the results of this extended testing are unsatisfactory, the welding shall be suspended until the causes of the defects have been established and rectified.

714 For welds where allowable defect sizes are based on an ECA, UT shall supplement radiographic testing, unless AUT is performed.

715 All NDT shall be performed after completion of all cold forming and heat treatment.

F 800 Cutting, forming and heat treatment

801 Attention shall be paid to local effects on material properties and any activities causing carbon contamination where this is relevant. Preheating of the area to be cut may be required. Carbon contamination shall be removed by grinding off the affected material.

Forming of material shall be according to agreed procedures.

F 900 Verification of dimensions and weight

901 Verification of dimensions should be performed in order to establish conformance with the required dimensions and tolerances.

902 Verification of dimensions verification of pipe strings for towing and spools shall include weight, and the distribution of weight and buoyancy.

F 1000 Corrosion protection and thermal insulation

1001 Application of coatings and installation of anodes shall meet the requirements of Sec.9.

1002 Acceptable temperature ranges for spooling operations shall be defined.

Guidance note:

Undesired events such as cracking of field joints may occur for low temperatures.

---e-n-d---of---G-u-i-d-a-n-c-e---n-o-t-e---

G. Hydrostatic Testing

G 100 Hydrostatic testing

101 Prior to performing hydrostatic testing the test object shall be cleaned and gauged.

102 The extent of the section to be tested shall be shown on drawings or sketches. The limits of the test, temporary blind flanges, end closures and the location and elevation of test instruments and equipment shall be shown. The elevation of the test instruments shall serve as a reference for the test pressure.

103 End closures and other temporary testing equipment shall be designed, fabricated, and tested to withstand the maximum test pressure, and in accordance with a recognised code.

104 Testing should not be performed against in-line valves, unless possible leakage and damage to the valve is considered, and the valve is designed and tested for the pressure test condition. Blocking off or removal of small-bore branches and instrument tappings should be considered in order to avoid possible contamination.

Considerations shall be given to pre-filling valve body cavities with an inert liquid unless the valves have provisions for pressure equalisation across the valve seats.

105 Welds shall not be coated, painted or covered, if the purpose of the test is 100% visual inspection. However, thin primer coatings may be used where agreed.

106 Welds may be coated or painted if the acceptance criterion is based on pressure observations.

107 Instruments and test equipment used for measurement of pressure, volume, and temperature shall be calibrated for accuracy, repeatability, and sensitivity. All instruments and test equipment shall possess valid calibration certificates with traceability to reference standards within the 6 months preceding the test. If the instruments and test equipment have been in frequent use, they should be calibrated specifically for the test.

108 Gauges and recorders shall be checked for correct function immediately before each test. All test equipment shall be located in a safe position outside the test boundary area.

109 The following requirements apply for instruments and test equipment:

- testers shall have a range of minimum 1.25 times the specified test pressure, with an accuracy better than

± 0.1 bar and a sensitivity better than 0.05 bar.

- temperature-measuring instruments and recorders shall have an accuracy better than ± 1.0°C
- pressure and temperature recorders are to be used to provide a graphical record of the pressure test for the total duration of the test.

110 The test medium should be fresh water or adequately treated sea water, as applicable.

Filling procedure shall ensure minimum air pockets.

111 Pressurisation shall be performed as a controlled operation with consideration for maximum allowable velocities in the inlet piping up to 95% of the test pressure. The final 5% up to the test pressure shall be raised at a reduced rate to ensure that the test pressure is not exceeded. Time shall be allowed for confirmation of temperature and pressure stabilisation before the test hold period begins.

112 The test pressure shall be according to the specified requirement.

113 When the test acceptance is based on observation of pressure variations, calculations showing the effect of temperature changes on the test pressure shall be developed prior to starting the test. Temperature measuring devices, if used, shall be positioned close to the test object and the distance between the devices shall be based on temperature gradients along the test object.

114 For hydrostatic testing of single components, e.g. bends, tees the following pressure holding times apply:

- when the test acceptance is based on 100% visual inspection, the holding time at test pressure shall be until 100% visual inspection is complete or 2 hours, whichever is longer.
- when the test acceptance is based on pressure observation, the holding time at test pressure shall not be less than 2 hours.

For hydrostatic testing of assemblies, e.g. pipe strings, stalks the following pressure holding times apply:

- when the test acceptance is based on 100% visual inspection, the holding time at test pressure shall be until 100% visual inspection is complete or 2 hours, whichever is longer.
- when the test acceptance is based on pressure observation, the holding time at test pressure shall not be less than 8 hours. Other holding times may be applied subject to agreement, e.g. subject to volumes to be tested.

115 The pressure test is acceptable for:

- 100% visual inspection when there are no observed leaks (e.g. at welds, flanges, mechanical connectors) and the pressure has at no time during the hold period fallen below 99% of the test pressure. 100% visual inspection shall only be acceptable where there is no risk that a leak may go undetected due to prevailing environmental conditions
- 100% pressure observation when the pressure has at no time during the hold period fallen below 99% of the test pressure and the test pressure profile over the test hold period is consistent with the predicted pressure profile taking into account variations in temperatures and other environmental changes.

116 Documentation produced in connection with the pressure testing shall, where relevant, include:

- test drawings or sketches
- pressure and temperature recorder charts
- log of pressure and temperatures
- calibration certificates for instruments and test equipment
- calculation of pressure and temperature relationship and justification for acceptance.

G 200 Alternative test pressures

201 For components fitted with pup pieces of material identical to the adjoining pipeline, the test pressure can be reduced to a pressure that produce an equivalent stress of 96% of SMYS in the pup piece.

202 If the alternative test pressure in G201 cannot be used and the strength of the pup piece is not sufficient:

- Testing shall be performed prior to welding of pup pieces. The weld between component and pup piece is regarded a pipeline weld and will be tested during pipeline system testing.

H. Documentation, Records, Certification and Marking

H 100 General

101 All base material, fittings and, flanges, etc. shall be delivered with Inspection Certificate 3.1 according to European Standard EN 10204 or accepted equivalent.

The inspection certificate shall include:

- identification the products covered by the certificate with reference to heat number, heat treatment batch etc.

- dimensions and weights of products
- the results (or reference to the results) of all specified inspections and tests
- the supply condition and the temperature of the final heat treatment.

102 Records from the qualification of the MPS and other documentation shall be in accordance with Sec.12.

103 Each equipment or component item shall be adequately and uniquely marked for identification. The marking shall, as a minimum, provide correlation of the product with the related inspection documentation.

104 The marking shall be such that it easily will be identified, and retained during the subsequent activities.

105 Other markings required for identification may be required.

106 Equipment and components shall be adequately protected from harmful deterioration from the time of manufacture until taken into use.

SECTION 9

CONSTRUCTION - CORROSION PROTECTION AND WEIGHT COATING

A. General

A 100 Objective

101 This section gives requirements and recommendations on:

- application (manufacture) of external pipeline coatings including field joint coatings and infill
- application (manufacture) of concrete weight coatings
- manufacture of galvanic anodes
- installation of galvanic anodes.

102 The objectives are to ensure that the external corrosion control system and any weight coating are designed and fabricated to ensure proper function for the design life of the systems. As to the last item above, it is a further objective to ensure that the fastening does not impose any damage or hazards affecting the integrity of the pipeline system.

A 200 Application

201 This section is applicable to the preparation of specifications for manufacture/installation of external corrosion control systems and for the manufacture of concrete weight coating during the construction phase. Such specifications shall define the requirements to properties of the coatings and anodes, and to the associated quality control.

202 Manufacture/installation of any impressed current CP systems for landfalls is not covered by this standard. The requirements in ISO 15589-1 shall then apply.

A 300 Systematic review

301 An overall requirement to systematic review in Sec.2 shall for this section imply:

- The selection of coating system and its detailed design shall take into considerations e.g. the pipe laying method, pipe loading conditions and pipeline operating conditions in service.
- The selection of coating system and its detailed design shall take into consideration compatibility between linepipe coating system, field joint coating system, infill and concrete coating (when applicable).
- In the coating purchase specification, as-applied coating properties shall be defined and requirements to methods, frequency and acceptance criteria for their verification shall be specified.
- Prior to start of coating application, essential application process parameters shall be defined by the coating applicator. The essential process parameters shall be project specific and should be verified in a Procedure Qualification Trial (PQT, see B202 and C402 below) to ensure that specified coating properties can be fulfilled. Quality control during production shall verify that the essential process parameters are maintained during production.

Guidance note:

Examples of how inadequate coating properties may result in failures are:

- Poor adhesion between steel surface and corrosion protective coating may result in partly or completely detachment of coating during storage or operation.
- Insufficient bonding to steel substrate/between coating layers, in combination with low ductility of as-applied coating may cause cracking of linepipe and/or field joints/infill during reeling of pipelines.
- Insufficient shear resistance capacity between corrosion coating and concrete coating may result in a safety risk during installation due to sudden sliding of the concrete coating relative to steel pipe, and/or damage to field joints and anodes during operation due to thermal axial expansion of the steel pipe relative to the concrete coating.

---e-n-d---of---G-u-i-d-a-n-c-e---n-o-t-e---

B. External Corrosion Protective Coatings

B 100 General

101 Properties of the coating (as-applied) and requirements to quality control during application shall be defined in a purchase specification (see Sec.6 C500).

102 For application of 3-layer polyolefin coatings (3-layer polyethylene/polypropylene), single layer fusion-bonded epoxy coatings and field joint coatings, requirements in ISO 21809 (part 1-3) shall apply with the additional requirements as specified below in Section B.

103 Recommended practice for application of linepipe coatings and field joint coating are given in DNV-RP-

F106 and DNV-RP-F102, respectively.

Guidance note:

DNV-RP-F106 and DNV-RP-F102 have emphasis on quality control procedures and documentation. They comply with and refer to ISO 21809 with some additional requirements for relevant coating systems (including some additional systems to those defined in ISO 21809). DNV-RP-F102 also covers field repairs of linepipe coating and infill, see Sec.6 D400. These documents are applicable to the preparation of coating specifications and can also be used as a purchase document if amended to include project and any operator specific requirements.

---e-n-d---of---G-u-i-d-a-n-c-e---n-o-t-e---

104 The design and quality control during application of field joint coatings is essential to the integrity of pipelines in HISC susceptible materials, including ferritic-austenitic (duplex) and martensitic stainless steel. Recommended practice for design and quality control during application of field joint coatings is given in DNV-RP-F102.

B 200 Coating materials, surface preparation, coating application and inspection/testing of coating

201 All coating work shall be carried out according to a project specific “Application Procedure Specification” (APS, also referred to as “Manufacturing Procedure Specification”, MPS). The following items shall be described in the procedure specification:

- receipt, handling and storage of coating materials
- surface preparation and inspection
- coating application and monitoring of essential process parameters
- inspection and testing of coating
- coating repairs and stripping of defect coating
- preparation of cut-backs (for linepipe coating)
- marking, traceability and handling of non-conformities
- handling and storage of coated pipes (for linepipe coating)
- documentation.

Material data sheets for coating, blasting and any other surface preparation materials may either be included in the APS or in a separate document. The purchaser may specify that the above documentation shall be submitted for approval prior to the start of production and any PQT (see B202).

202 A coating Procedure Qualification Trial (PQT; also referred to as an “application procedure qualification test” or “pre-production qualification test”) should be executed and accepted by Purchaser before starting the coating work, especially for coating systems which rely on a curing process to achieve the specified properties. For Field Joint Coating (FJC) and infill, a Pre-Production Trial (PPT) should also be performed. The purpose of the qualification is to confirm, prior to the start of regular production, that the coating Application Procedure Specification (APS), coating materials, tools/equipment and personnel to be used for production are adequate to achieve the specified properties of the coating.

203 An Inspection and Testing Plan (ITP; sometimes referred to as an “inspection plan” or “quality plan”) shall be prepared and submitted to Purchaser for acceptance. The ITP shall refer to the individual application and inspection/testing activities in consecutive order, define methods/standards, frequency of inspection/testing, checking/calibrations, and acceptance criteria. Reference shall further be made to applicable reporting documents and procedures for inspection, testing and calibrations.

204 Inspection and testing data, essential process parameters, repairs and checking/calibrations of equipment for quality control shall be recorded in a “daily log” that shall be updated on a daily basis and be available to Purchaser on request at any time during coating production.

205 The daily log format and final documentation index should be prepared for acceptance by Purchaser prior to start of production.

C. Concrete Weight Coating

C 100 General

101 The objectives of a concrete weight coating are to provide negative buoyancy to the pipeline, and to provide mechanical protection of the corrosion coating and linepipe during installation and throughout the pipeline's operational life.

102 The concrete weight coating (thickness, strength, density, amount of reinforcement) shall be designed for the specific project; i.e. the actual installation, laying and operation conditions for the pipeline shall then be taken into consideration.

103 For materials and application of concrete weight coating requirements in ISO 21809-5 shall apply with the additional and modified requirements as specified below in Section C.

Additional or modified requirements

104 Paragraphs containing additional requirements to ISO 21809-5 are marked at the end of the relevant paragraph with AR.

Paragraphs containing requirements that are modified compared to ISO 21809-5 are marked at the end of the relevant paragraph with MR.

C 200 Materials

201 Cement shall be moderate sulphate resistant Portland cement equivalent to Type II according to ASTM C150. MR

202 The tricalcium aluminate (C3A) content of the cement shall not exceed 8%. MR

203 The percentage of the recycled concrete used as aggregate shall not exceed 7% by weight. MR

204 The reclaimed concrete content in the concrete mix should not exceed 10% by weight. Use of higher amounts shall be verified by testing confirming that the required concrete coating properties can be achieved. AR

C 300 Concrete mix

301 The content of chloride in the concrete mix, calculated as free CaCl_2 shall not exceed 0.4% of the weight of the cement. AR

C 400 Coating application

401 All coating work shall be carried out according to an Application Procedure Specification (APS), AR. The following items shall be described in the APS:

- raw materials, including receipt, handling and storage
- concrete mix design
- reinforcement percentage and placement
- coating application and curing
- inspection and testing, including calibrations of equipment
- coating repairs
- pipe tracking, marking and coating documentation
- handling and storage of coated pipes.

Purchaser may specify that the APS shall be subject to approval prior to start of production and any PQT. AR

402 A coating Procedure Qualification Trial (PQT; in ISO 21809-5 referred to as “qualification test”) shall be executed and accepted by Purchaser before starting the coating work.

403 Changes in type of linepipe coating and/or applicator and/or changes in concrete constituent materials and/or concrete mix shall require a new PQT. AR

404 Repair methods shall be included in the PQT. AR

405 The following inspections and tests shall also be carried out during PQT. AR:

- Testing aggregates according to ASTM C33 or equivalent
- Determining water content in the concrete mix
- Determining cement content in the concrete mix and water/cement ratio
- Inspection of linepipe coating (holiday detection)
- Calibration/verification of all measuring and weighting equipment

Guidance note:

Purchaser may consider performing a full scale water absorption test, shear resistance test and/or impact resistance test as an integral part of PQT. Also, Purchaser may consider a requirement on production of several pipes to demonstrate the applicator capability of continuous production of conforming pipes.

---e-n-d---of---G-u-i-d-a-n-c-e---n-o-t-e---

406 The following modification of acceptance criteria for inspections and tests during PQT shall apply. MR:

- The thickness of the concrete coating shall not be less than 40 mm
- The minimum in-situ compressive strength of the concrete coating shall not be less than 40 MPa. The mean strength shall be calculated from compressive test results of three drilled cores obtained from one pipe, with no single test results less than 34 MPa.

407 The concrete coating shall be reinforced by steel bars welded to cages or by wire mesh steel. The minimum percentage of the steel reinforcement shall be 0.5% circumferentially and 0.08% longitudinally of the cross-sectional area of the concrete coating. MR

408 The minimum diameter of circumferential cage reinforcement shall be 5 mm. MR

409 The maximum spacing between circumferential and longitudinal cage reinforcement shall be 125 mm and 250 mm, respectively. AR

410 The minimum diameter of wire mesh reinforcement shall be 2 mm. MR

411 The minimum overlap of wire mesh reinforcement shall be 1.5 x distance between the wires or 25 mm (whichever is greater). AR

412 Minimum concrete cover to the reinforcement shall be 15 mm for concrete thickness less or equal to 50 mm and minimum 20 mm for concrete thickness greater than 50 mm. MR

413 The thickness of the concrete coating shall not be less than 40 mm. MR

C 500 Inspection and testing

501 An Inspection and Testing Plan (ITP) shall be prepared and submitted to Purchaser for acceptance in due time prior to start of production. The ITP shall define the methods and frequency of inspection, testing and calibrations, acceptance criteria and requirements to documentation. Reference shall further be made to applicable reporting documents and procedures for inspection, testing and calibration. AR

502 Other standards for testing than those specified in DNV-OS-F101 may be used, provided that it is documented during PQT that the quality of materials and applied concrete weight coating will not be lower than when testing according to the standards specified in this rule. AR

503 The dimensions of cube and cylinder specimens (cast from fresh concrete) for testing the concrete compressive strength shall be 100 mm × 100 mm × 100 mm cubes or 100 mm × 100 mm cylinders. AR

504 For hardened concrete drill cores specimens, the diameter of the cylinder shall not be less than 38 mm and the preparation shall be according to ASTM C31 or EN 12390-2. AR

505 The following inspections and tests shall also be carried out during production. AR:

- inspection of linepipe coating (holiday detection) before concrete coating application
- calibration of all measuring and weighing equipment
- content of recycled and reclaimed materials in the concrete mix
- sounding test.

Guidance note:

Purchaser may consider performing a full scale water absorption test as part of production testing.

---e-n-d---of---G-u-i-d-a-n-c-e---n-o-t-e---

506 The following modification of acceptance criteria for inspections/tests during production shall apply. MR:

- *Concrete coating thickness*: minimum 6 measurements on each pipe.

507 Inspection and testing data, repairs, essential process parameters and calibrations of equipment for quality control shall be recorded in a “daily log” that shall be updated on a daily basis and be available to the purchaser on request at any time during coating production. AR

508 The daily log format and final documentation index should be prepared for acceptance by Purchaser prior to start of production.

D. Manufacture of Galvanic Anodes

D 100 Anode manufacture

101 Requirements to anode manufacture shall be detailed in a purchase specification (‘anode manufacturing specification’). A manufacturing specification for pipeline bracelet anodes shall cover all requirements in ISO 15589-2.

Recommended practice for anode manufacture with some additional requirements and guidance to ISO, primarily for quality control, is given in DNV-RP-F103.

102 The manufacturer of bracelet anodes shall prepare a ‘manufacturing procedure specification’ (MPS) describing anode alloy (e.g. limits for alloying and impurity elements) and anode core materials, anode core preparations, anode casting, inspection and testing, coating of bracelet anode surfaces facing the pipe surface, marking and handling of anodes, and documentation.

103 An “Inspection and Testing Plan” (ITP) for manufacture of bracelet anodes, shall be prepared and submitted to the purchaser for acceptance. It is further recommended that the inspection and testing results are compiled in a ‘daily log’

Reference is given to DNV-RP-F103 for requirements and guidance for preparation of these documents and to a ‘Procedure Qualification Trial’ (PQT). For manufacture of other types of anodes than pipeline bracelet

anodes, reference is made to DNV-RP-B401.

Guidance note:

The requirement for an ITP is an amendment to ISO 15589-2.

---e-n-d---of---G-u-i-d-a-n-c-e---n-o-t-e---

104 For each anode type/size, the manufacturer shall prepare a detailed drawing showing location and dimensions of anode inserts, anode gross weight and other details as specified in a purchase document

105 The anode manufacturer shall prepare a detailed procedure for electrochemical testing in compliance with the agreed standard. An outline procedure for electrochemical testing of anode material performance during anode manufacture is given in Annex B of DNV-RP-B401 and in Annex D of ISO 15589-2.

106 Marking of anodes shall ensure traceability to heat number. Anodes should be delivered according to ISO 10474, Inspection Certificate 3.1.B or EN 10204, Inspection Certificate 3.1.

E. Installation of Galvanic Anodes

E 100 Anode installation

101 Installation of anodes shall meet the requirements in ISO 15589-2. Recommended practise for installation of anodes with some additional requirements and guidelines, primarily for quality control, are given in DNV RP-F103.

102 For martensitic and ferritic-austenitic (duplex) stainless steels and for other steels with SMYS > 450 MPa, no welding for anode fastening (including installation of doubling plates) should be carried out on linepipe or other pressure containing components.

Guidance note:

The requirement above is an amendment to ISO 15589-2. Most CP related HISC damage to pipeline components in CRA's have occurred at welded connections of galvanic anodes to the pipe walls. To secure adequate fastening of pipeline bracelet anodes for compatibility with the applicable installation techniques, forced clamping of anodes is applicable in combination with electrical cables attached to anodes and pipeline by brazing. However, for many applications, CP can be provided by anodes attached to other structures electrically connected to the pipeline (see Sec.6 D500). For installation of anodes on such structures, reference is made to DNV-RP-B401.

---e-n-d---of---G-u-i-d-a-n-c-e---n-o-t-e---

103 All welding or brazing of anode fastening devices and connector cables shall be carried out according to a qualified procedure (see Appendix C of this standard) to demonstrate that the requirements in ISO 13847 to maximum hardness (welding/brazing) and copper penetration (brazing including 'aluminothermic welding') are met.

104 For linepipe to be concrete weight coated, electrical contact between concrete reinforcement and the anodes shall be prevented. The gaps between the anode half shells may be filled with asphalt mastic, polyurethane or similar. Any spillage of filling compound on the external anode surfaces shall be removed.

SECTION 10 CONSTRUCTION – OFFSHORE

A. General

A 100 Objective

101 This section provides requirements as to studies, analyses and documentation shall be prepared and agreed for the offshore construction, and further to provide requirements for the installation and testing of the complete submarine pipeline system.

A 200 Application

201 This section is applicable to offshore construction of submarine pipeline systems designed and constructed according to this standard.

Guidance note:

Parts of this section may also be applied for construction and installation of flexible pipelines or risers, subject to agreement. In particular may subsection E be relevant in such cases.

---e-n-d---of---G-u-i-d-a-n-c-e---n-o-t-e---

A 300 Systematic review

301 The overall requirement to systematic review in Sec.2 shall be reflected in the offshore construction of the pipeline.

302 Systematic analyses of equipment and offshore construction shall be performed in order to identify possible critical items or activities which could cause or aggravate a hazardous condition, and to ensure that effective remedial measures are taken.

303 The extent of systematic review shall depend on criticality of operations and experience from previous similar operations.

304 The systematic analyses should be carried out as a failure mode effect analysis (FMEA) for equipment and hazard and operability studies (HAZOP) for critical operations. Recommended practice for FMEA and HAZOP is given in DNV-RP-H101. For HAZOP, reference is also made to API RP 17N.

Guidance note:

Typical items to be covered for HAZOP include:

- simultaneous operations
- lifting operations including pipe joints transportation and storage
- dry and wet buckles including flooding of pipe
- initiation and lay down including shore pull
- operations inside safety zones
- critical operations (laying in short radii curves, areas with steep slopes etc.)
- failure of equipment and measuring and monitoring devices
- tie-in operation
- pre-commissioning activities
- environmental conditions and weather criteria
- emergency abandonment
- loss of station keeping capabilities
- survey.

It is desired to mitigate potential hazards by engineering measures.

---e-n-d---of---G-u-i-d-a-n-c-e---n-o-t-e---

305 The results of the FMEA analysis or HAZOP studies shall also be used in determining the extent and depth of verification of equipment and procedures.

A 400 Installation manual

401 An installation manual shall be prepared by the Contractor, see Subsection L.

A 500 Quality assurance

501 The Contractor shall as a minimum have an implemented quality assurance system meeting the requirements of ISO 9001 *Quality management systems – Requirements* or equivalent. Further requirements for quality assurance are given in Sec.2 B500.

502 The installation contractor shall demonstrate compliance with QA/QC system.

503 The Contractor shall use competent personnel at all stages of the project. Permanent technical, managerial and planning personnel shall have adequate education, training and experience commensurate with their duties and level of supervision under which the work is performed. These requirements shall be part of the contractor's quality management system.

504 All engineering analysis and calculations required to support installation procedures shall be performed by technical staff with the appropriate educational qualifications and experience. Such work shall be discipline checked and approved by responsible engineers in the contractor's organization or external consultants.

505 For offshore personnel, contractor shall have a competence assurance program similar to the IMCA Competence Assurance and Assessment framework or equivalent, for all personnel involved in marine, diving, offshore survey, remote operations and ROV work.

506 A master language for communications shall be defined. Platforms for where master language shall be used shall be defined.

Guidance note:

The purpose of defining a master language is to avoid miscommunications and to ensure that all parties may receive and understand communications. The master language is normally defined by the Operator. For platforms where master language is not required, other languages may be used as appropriate.

---e-n-d---of---G-u-i-d-a-n-c-e---n-o-t-e---

507 Key personnel shall have sufficient verbal communication skills in the common language used during operations.

B. Pipe assemblies onshore

B 100 Pipe assemblies onshore

101 For pipe assemblies onshore, reference is given to Sec.8 F.

102 For linepipe temporary storage and transportation, see Sec.8 F400.

C. Pipeline Route, Pre-installation Survey and Preparation

C 100 Pre-installation route survey

101 A pre-installation survey of the pipeline route should be performed in addition to the route survey required for design purposes covered by Sec.3 C600 if:

- the time elapsed since the previous survey is significant
- a change in seabed conditions is likely to have occurred
- the route is in areas with heavy marine activity
- new installations or facilities are present in the area
- seabed preparation work is performed within the route corridor after previous survey.

102 The pre-installation survey should determine:

- potential new/previously not identified hazards to the pipeline and the installation operations
- location of wrecks, submarine installations and other obstructions such as mines, debris, rocks and boulders that might interfere with, or impose restrictions on, the installation operations
- that the present seabed conditions confirm those of the survey required in Sec.3
- any other potential hazards due to the nature of the succeeding operations.

103 The extent of, and the requirements for, the pre-installation route survey shall be specified.

C 200 Seabed preparation including shore approaches

201 Seabed preparation may be required to:

- remove obstacles and potential hazards interfering with the installation operations
- prevent loads or load effects that occur as a result of seabed conditions or shore area such as unstable slopes, sand waves, deep valleys and possible erosion and scour from exceeding the design criteria
- prepare for pipeline and cable crossings
- infill depressions and remove high-spots to prevent unacceptable free spans
- carry out any other preparation due to the nature of the succeeding operations
- avoid damage to coating and anodes and other attachments to the pipeline.

202 The extent of, and the requirements for, seabed preparation shall be specified. The laying tolerances shall

be considered when the extent of seabed preparation is determined.

203 Where trench excavation is required before pipelaying, trench shall be excavated to a sufficiently smooth profile.

C 300 Existing pipelines and cables including crossings

301 The location of any other pipelines, cables or other infrastructure shall be identified.

302 Preparations for crossing of pipelines and cables shall be carried out according to a specification detailing the measures adopted to avoid damage to both installations. The operations should be monitored to confirm proper placement and configuration of the supports. Support and profile over the existing installation shall be in accordance with the accepted design.

303 The specification shall state requirements concerning:

- minimum separation between existing installation and the pipeline
- co-ordinates of crossing
- marking of existing installation
- confirmation of position and orientation of existing installations on both sides of the crossing
- lay-out and profile of crossing
- depth of cover
- vessel anchoring
- installation of supporting structures or gravel beds
- methods to prevent scour and erosion around supports
- monitoring and inspection methods
- tolerance requirements
- condition of landfall
- any other requirements.

D. Installation Spread

D 100 General

101 These requirements are applicable for vessels performing pipeline and riser installation and supporting operations. Specific requirements for installation equipment onboard vessels performing installation operations are given in the relevant subsections.

102 The organisation of key personnel with defined responsibilities and lines of communication shall be established prior to start of the operations. Interfaces with other parties shall be defined.

103 All personnel shall be qualified for their assigned work. Key personnel shall have sufficient verbal communication skills in the common language used during operations.

104 Manning level should comply with IMO Res. A.1047 (27) - *Principles of minimum safe manning*. Non-propelled vessels shall have similar manning and organisation as required for propelled units of same type and size.

105 Vessels and equipment shall have a documented maintenance programme covering all systems vital for the safety and operational performance of the vessel, related to the operation to be performed. The maintenance programme shall be presented in a maintenance manual or similar document.

D 200 Vessels

201 All vessels shall have valid class with a recognised classification society. The valid class shall cover all systems of importance for the safety of the operation. Further requirements to vessels shall be given in a specification stating requirements for:

- anchors, anchor lines and anchor winches
- anchoring systems
- thrusters in case of thruster assisted mooring
- positioning and survey equipment
- dynamic positioning equipment and reference system
- alarm systems, including remote alarms when required
- general seaworthiness of the vessel for the region
- cranes and lifting appliances
- pipeline installation equipment
- any other requirement due to the nature of the operations.

202 Status reports for any recommendations or requirements given by National Authorities and/or classification societies, and status of all maintenance completed in relation to the maintenance planned for a relevant period, shall be available for review.

203 An inspection or survey shall subject to agreement be performed prior to mobilisation of the vessels to confirm that the vessels and their principal equipment meet the specified requirements and are suitable for the intended work.

204 The scale of fire fighting and lifesaving appliances on board shall, as a minimum, be in accordance with the scales prescribed in SOLAS corresponding to the number of personnel on board the vessel.

D 300 Positioning systems

301 The installation barge/vessel shall have a position/heading keeping system able to maintain a desired position/heading within the accuracy and reliability required for the planned operation and the environmental conditions. Reference is given to D400 and D500 for more details.

302 The operation/installation shall be planned and executed with use of position/heading reference system(s) of suitable type, accuracy and reliability required for the operation(s) and type of vessel(s) involved.

303 The positioning/heading reference systems shall be calibrated and capable of operating within the specified limits of accuracy prior to start of the installation operations.

304 Installation in congested areas and work requiring precise relative location may require local systems of greater accuracy, such as acoustic transponder array systems. Use of ROV's to monitor and assist the operations is recommended and should be considered.

305 The positioning/heading reference system shall as a minimum provide information relating to:

- position relative to the grid reference system used
- geographical position
- heading
- offsets from given positions
- vertical reference datum(s).

D 400 Anchoring systems, anchor patterns and anchor handling

401 Anchoring systems for vessels kept in position/heading by anchors (with or without thruster assistance) while performing marine operations shall meet the following requirements:

- Instruments for reading anchor line tension and length of anchor lines shall be fitted in the operations control room or on the bridge, and also at the winch station
- Remotely operated winches shall be monitored from the control room or bridge, by means of cameras or equivalent
- Instrumentation for reading thruster output and available electrical power for thrusters shall be available at bridge and/or in the operation control room.

402 Anchor handling vessels shall be equipped with:

- a surface positioning reference system of sufficient accuracy. High accuracy is required for anchor drops in areas with strict requirements to control of anchor position, typical within safety zone of existing installations, proximity of pipelines or areas of archeological or environmental importance
- computing and interfacing facilities for interfacing with lay vessel, trenching vessel or other anchored vessels.
- Latest revision of charts for the whole area of operation

403 Procedures for the anchor handling shall be established, ensuring that:

- anchor locations are in compliance with the anchor pattern for the location
- requirements of operators of other installations and pipelines for anchor handling in the vicinity of the installation are known, and communication lines established
- position prior to anchor drop is confirmed
- anchor positions are monitored at all times, particularly in the vicinity of other installations and pipelines
- any other requirement due to the nature of the operations is fulfilled.

Guidance note:

In order to ensure correct positioning of anchors, the line length measurements should be reset at the point of the anchor shackle being at the stern roller and accurate information of line tension should be ensured.

---e-n-d---of---G-u-i-d-a-n-c-e---n-o-t-e---

404 All mooring equipment shall hold a valid certificate. There shall be procedures in place for handling and regular inspection of all mooring equipment.

405 For mooring systems using synthetic fibre lines, instructions for handling, use and storage as provided by manufacturer and/or stated on certificate shall be followed. Contact with the seabed shall be avoided at any time unless the fibre ropes have been certified for such contact.

406 Anchor patterns shall be predetermined for each vessel using anchors to maintain position. Different

configurations for anchor patterns may be required for various sections of the pipeline, especially in the vicinity of fixed installations and other subsea installations or other pipelines or cables.

407 The minimum allowable number of anchors to be used during pipeline installation shall be established.

408 Anchor patterns shall be according to the results of mooring analyses and shall be verified to have the required capacity for the proposed location, time of year and duration of operation. Safe distance to other installation and non-anchoring zones shall be established, and the possibility to leave the site in an emergency situation shall be considered.

Guidance note:

For weather restricted operations and mooring, see DNV-OS-H101. For non-weather restricted operations and mooring, see DNV-OS-E301.

---e-n-d---of---G-u-i-d-a-n-c-e---n-o-t-e---

409 The mooring system shall as a minimum be analysed for:

- An ultimate limit state (ULS) to ensure that the individual lines and anchors have adequate strength to withstand the load effects imposed by extreme environmental actions
- An ultimate limit state (ULS) to ensure that the individual lines have the adequate strength and the vessel/barge is kept within acceptable positions for the environmental limiting conditions for the operation.
- An accidental limit state (ALS) to ensure that the mooring system has the adequate capacity to withstand the failure of one mooring line, or in case of thruster assisted mooring, failure of one thruster or failure in thrusters' control or power systems.

410 Holding capacity of anchor shall be documented, and potential dragging anchors shall be assessed. The anchor holding capacity shall be based on actual soil condition and type of anchors to be used. Various anchors may have various performance in different soils, and evaluation of the appropriate anchor type shall be performed. Special caution should be paid to holding capacity on sand.

411 Each anchor pattern shall be clearly shown on a chart of adequate scale. The pattern should include allowable tolerances. All subsea installations, infrastructure and other anchor restricted zones shall be shown in the chart.

412 If using anchor handling tug as live anchor, the tug should as a minimum hold a DP class according to DP equipment class 2. The winch and DP system should be linked ensuring winch tension to be considered in the system. Live anchor should not be used in critical operations and inside the safety zone.

413 Station-keeping systems based on anchoring shall have adequate redundancy or back-up systems in order to ensure the pipeline integrity and that other vessels and installations are not endangered by partial failure.

Guidance note:

The pipeline integrity check should, as a minimum, include the following cases:

- Worst case for mooring failure
- Mooring failure for the most loaded case for pipeline as identified in dynamic analysis.

---e-n-d---of---G-u-i-d-a-n-c-e---n-o-t-e---

414 Safe distances are to be specified between an anchor, its cable and any existing fixed or subsea installations and infrastructure, both for normal operations and emergency conditions.

Guidance note:

Minimum clearances may vary depending on requirements of operators of other installation/pipeline and national requirements.

---e-n-d---of---G-u-i-d-a-n-c-e---n-o-t-e---

415 The anchor position, drop zone and wire catenary should be established taking into account the water depth, wire tension and wire length. Confirmation of anchor positioning after installation shall be confirmed at regular intervals depending on required accuracy and criticality, and counteractive measures taken when found required. Monitoring systems shall be considered.

416 During anchor running, attention shall be paid to the anchor cable and the catenary of the cable, to maintain minimum clearance between the anchor cable and any subsea installations and infrastructure or obstacles.

417 All anchors transported over subsea installations and infrastructure shall be secured on deck of the anchor handling vessel.

D 500 Dynamic positioning

501 Vessels performing pipelaying activities using dynamic positioning systems for station keeping and location purposes shall be designed, equipped and operated in accordance with IMO MSC/Circ.645 (Guidelines for Vessels with Dynamic Positioning Systems) and the corresponding class notations from a recognised classification society.

502 Selection of required DP equipment class for the operation shall comply with national requirements and in addition be based upon a risk assessment of the actual installation and location.

Guidance note:

The following DP equipment class should apply:

- Minimum equipment Class 2 for operations outside the safety zone for live installation (surface or subsea)
- Equipment Class 3 for operations inside the safety zone for live installations
- Equipment Class 3 for manned subsea operations or other operations where a sudden horizontal displacement of the vessel may have severe consequences for personnel.

For operations inside the safety zone, vessels with lower equipment classes may be accepted subject to agreement on a case by case basis. Elements to evaluate with regard to acceptance of lower equipment class are:

- the vessel does not exceed the vessel size of which the facility is designed for with regard to withstanding collision.
- the consequences of single failures, including fire and flooding, will not increase significantly
- availability of reliable positioning reference systems
- possibility of operating with open waters on leeward side
- risk reducing measures as extra DP manning, engine room manning and fire watch.

---e-n-d---of---G-u-i-d-a-n-c-e---n-o-t-e---

503 Sufficient DP capacity shall be documented by capability plots. The plots shall be relevant for the planned project based on correct vessel lay-out, including project specific modifications, and relevant pipeline and tension. The plots shall cover normal operation as well as worst case single failure from FMEA.

Guidance note 1:

The capacity plots should be provided for two scenarios for the same weather conditions:

- 1, all system fully functional
- 2, worst case failure mode, or an amalgamation of the worst cases

For capacity plots, reference is made to IMCA M140.

---e-n-d---of---G-u-i-d-a-n-c-e---n-o-t-e---

Guidance note 2:

For worst single failure concept, see DNV ship rules Pt.6 Ch.7 – Dynamic Positioning Systems, and in IMO MSC/circ. 645

---e-n-d---of---G-u-i-d-a-n-c-e---n-o-t-e---

504 For critical operations monitoring/displaying of actual DP capacity for actual weather conditions at site are recommended.

Guidance note:

Equipment classes 2 and 3 has a software function, normally known as “consequence analysis”, which continuously verifies that the vessel will remain in position even if the worst case failure occurs. This analysis should verify that the thrusters remaining in operation after the worst case failure can generate the same resultant thruster force and moment as required before the failure.

The consequence analysis should provide an alarm if the occurrence of a worst case failure would lead to a loss of position due to insufficient thrust for the prevailing environmental conditions. For operations which will take a long time to safely terminate, the consequence analysis should include a function which simulates the thrust and power remaining after the worse case failure, based on manual input of weather trend.

---e-n-d---of---G-u-i-d-a-n-c-e---n-o-t-e---

505 Due consideration should be given to the reference systems limitations regards reliability, accessibility and quality.

506 The DP operators shall be familiar with the vessel specific FMEA as well as the contingency plans for the operation in question.

507 Key elements of the contingency planning measures should be located in the vicinity of the DP operator station, so that situation specific required actions are immediately available to the DP operator.

508 DP operation station and tensioner system operation station should be located in the vicinity of each other ensuring close communication between the operators and availability/monitoring of vital information.

D 600 Cranes and lifting equipment

601 Cranes and lifting equipment shall meet applicable statutory requirements. Certificates for the equipment, valid for the operations and conditions under which they will be used, shall be available on board for review.

D 700 Layvessel arrangement, laying equipment and instrumentation

701 The tensioning system shall operate in a fail-safe mode and shall have adequate pulling force, holding force, braking capacity and squeeze pressure to maintain the pipe under controlled tension. The forces applied

shall be controlled such that no detrimental damage to the pipeline or coating will occur.

702 The installation vessel tensioning system arrangement shall therefore be such that:

- the tensioning system capacity shall have sufficient redundancy to allow failure of individual components
- in case of failure in the tensioning system, the pipeline installation shall not re-start before the system has been repaired or have enough redundancy to allow for additional failures.

703 The pipe joints, stalks and pipeline shall be sufficiently supported by rollers, tracks or guides that allow the pipe to move axially. Supports shall prevent damage to coating, field joint coatings, anodes and in-line assemblies, and rollers shall move freely. The vertical and horizontal adjustment of the supports shall ensure a smooth transition from the vessel onto the stinger, ramp or lay tower, to maintain the loading on the pipeline within the specified limits. The support configuration shall be related to a clear and easily identifiable datum.

704 The abandonment and recovery system (A&R) should be able to abandon the pipeline safely if waterfilled. In case the recovery system is incapable of recovering the pipeline, alternative methods should be available.

705 A sufficient amount of instrumentation and measuring devices shall be installed to ensure that monitoring of essential equipment and continuous digital storage of all relevant parameters required for configuration control and control of the operating limit conditions can be performed.

The following minimum instrumentation and monitoring is required:

Tensioning system:

- actual tension, tension settings and variance to set point
- squeeze pressure.

Stinger, ramp:

- pipeline and A&R wire position with respect to the last roller or guide
- roller reaction loads on the roller introducing the stinger curvature
- roller reaction loads (vertical and horizontal), as a minimum for stinger tip
- stinger and ramp configuration.

Guidance note:

Pipeline and wire position with respect to the last roller or guide may be monitored using underwater camera(s), sonar, ROV or diver.

---e-n-d---of---G-u-i-d-a-n-c-e---n-o-t-e---

Lay configuration:

- lay parameter monitoring and recording as applicable to the installation method (see F111).

Touch down monitoring:

- appropriate systems for touch down monitoring capable of operating under the expected weather conditions.

Buckle detection:

- appropriate instrumentation and monitoring system for the applied buckle detection method
- pulling wire tension and length recorder in case buckle detector is chosen as buckle detection method.

Winches:

- abandonment and recovery system shall be equipped with wire tension and length recorder
- anchor winches shall meet the requirements given in D400.

Vessel:

- vessel position
- vessel movements such as roll, pitch, sway, heave
- water depth
- vessel draft and trim
- wind strength and direction
- direct or indirect indication of sagbend curvature and strain.

Vessels used for installation by towing:

- measuring equipment that continuously displays and records the towing speed and tensions
- measuring equipment that continuously displays and monitors the depth of the pipestring and its distance from the seabed
- measuring equipment that continuously display the position of any ballast valves. The flow rates during any ballasting and de-ballasting are to be displayed.

— Strain gauges to monitor the stresses in the pipestring during tow and installation shall be considered

706 All measuring equipment shall be calibrated and adequate documentation of calibration shall be available onboard the vessel prior to start of work and during the whole operation. All measuring equipment used shall be provided with an adequate amount of spares to ensure uninterrupted operation.

707 Direct reading and processing of stored records from all required essential instrumentation and measuring devices, shall be possible at the vessels bridge.

708 Correlation of recorded data and pipe identifications numbers shall be possible.

709 The function of essential measuring devices shall be verified at regular intervals.

710 Other measuring and recording systems or equipment shall be required if they are essential for the installation operation.

D 800 Mobilization

801 All personnel shall be familiarized with the operation to be performed. More detailed familiarization shall be performed for personnel specific work tasks.

802 Personnel involved in critical operations should participate in a risk assessment for the specific operation. Personnel involved in critical operations shall participate in a safe job analysis or toolbox talk ensuring that an understanding of the involved risk related to the operation is understood.

803 Equipment needed for the operation shall be defined in and mobilised according to the mobilisation manual.

804 Stinger, ramp or lay tower shall be adjusted to the correct configuration to ensure a smooth transition from the vessel to the outboard stinger, ramp or lay tower end, and to maintain the loading on the pipeline within the specified limits. The pipeline support geometry shall be verified prior to laying, and the accepted height and spacing of supports shall be permanently marked or otherwise indicated. If the stinger, ramp or lay tower can be adjusted during laying operations, it shall be possible to determine the position and configuration by reference to position markings or indicators.

805 Trim, tilt and ballasting shall also be verified to be according to procedures prior to laying.

806 Procedures for safe lifting operations shall be in place.

807 All pipes, anodes, consumables, equipment etc. shall be seafastened within the environmental limits expected for the area of the operation.

D 900 Qualification of vessel and equipment

901 Vessel and equipment shall be qualified to do installation work within the specified operating limits. Re-qualification is required if significant modification or alternation to the vessel, equipment or software has been made.

902 Qualification shall be done according to a qualification plan based on a systematic review of the specified operating limits for the vessel and all equipment.

903 Qualification shall be done based on a combination of desktop review, analyses, HAZID/HAZOP, FMECA, simulation tests and test laying.

904 Combined positioning system/tensioning system tests shall be done by simulating pipeline pull, tensioning system failures and redundancy tests during pull.

D 1000 General calibration and testing

1001 Essential equipment shall be calibrated against a certified load cell. If essential components for the equipment such as load cells, amplifiers or software are replaced or modified the equipment shall be tested and re-calibrated. Indications of equipment out of calibration should trigger a re-calibration.

Guidance note:

Typical essential equipment can be, but are not limited to, tensioners, clamps, reel, winches, cranes, lifting equipment, conveyor system, bevelling machines, internal line-up clamp, field joint coating system, positioning systems.

---e-n-d---of---G-u-i-d-a-n-c-e---n-o-t-e---

1002 The certified load cell used for calibration shall have a certificate from a recognised certification body. The certificate for the load cell used for calibration should not be older than 6 months.

Guidance note:

A recognised certification body will have a competent laboratory that can ensure traceability and adequate procedures. Reference is given to ISO/IEC 17025.

---e-n-d---of---G-u-i-d-a-n-c-e---n-o-t-e---

1003 Testing and calibration shall be done according to the test procedures. Test procedures shall be subject to agreement.

1004 The test procedures shall provide documented acceptance criteria for the testing and calibration.

1005 The acceptance criteria shall be evaluated and set according to the pipeline integrity. Any deviation from the correct value shall be accounted for.

1006 Calibration and testing should be performed and planned such that it can be witnessed in agreement with Operator.

1007 Equipment should be tested and calibrated to the maximum equipment capacity or alternatively up to maximum expected dynamic or accidental loads + 50%, whichever is less.

1008 During testing and calibration the complete load range should be covered. For linear trends at least five load steps should be applied up to maximum expected dynamic loads, more steps are required when testing to maximum capacity. Non-linear trends require higher numbers of load steps. Cyclic loading should be considered.

Guidance note:

Loss of main power and loss of signal should be tested by removing fuses or cables.

---e-n-d---of---G-u-i-d-a-n-c-e---n-o-t-e---

D 1100 Calibration and testing frequency

1101 The calibration and testing of essential equipment should as a minimum be performed on an annual basis.

1102 Tensioning system review test shall be done as a minimum on an annual basis. This includes test combinations of tensioners, clamps and reel, and testing of single tensioner failure when running two or more tensioners, test redundancy of single tensioners, fail safe actions, loss of main power and loss of signal.

1103 Abandonment and recovery system test shall be done as a minimum on an annual basis (fail safe actions, loss of main power and loss of signal).

1104 For each specific project, testing and documentation of vessels and equipment shall as a minimum include:

- In-field dynamic positioning system test
- Fail safe testing to max expected level of tension for the project.
- buckle detection system
- stinger control and monitoring devices including roller load cells
- calibration records of critical/essential equipment, including welding machines and automated NDT equipment
- maintenance records for critical/essential equipment, including welding machines and automated NDT equipment
- maintenance/calibration records of critical/essential equipment on support vessels.
- Pull test of the tensioning and pipe holding system to verify sufficient squeeze pressure and friction.

Subject to agreement, the annual testing and calibration may be sufficient for the project. If the annual testing is performed with a different set up (e.g. different clamps or pads or pipe diameter), re-testing should be performed.

1105 Re-testing should be performed in case equipment is maintained. In case re-testing is not performed this shall be based upon an evaluation which shall be documented.

1106 Re-testing shall be performed in case equipment is changed or modified.

E. Welding and Non-destructive Testing

E 100 General

101 Requirements for welding processes, welding procedure qualification, execution of welding and welding personnel are given in Appendix C.

102 Requirements for mechanical and corrosion testing for qualification of welding procedures are given in Appendix B.

103 Requirements for methods, equipment, procedures, acceptance criteria and the qualification and certification of personnel for visual examination and non-destructive testing (NDT) are given in Appendix D. Selection of non-destructive methods shall consider the requirements in App.D A400.

104 Requirements to automated ultrasonic testing (AUT) are given in Appendix E.

E 200 Welding

201 Pipes shall be bevelled to the correct configuration, checked to be within tolerance, and inspected for damage. Internal line-up clamps should be used. Acceptable alignment, root gap and staggering of longitudinal

welds shall be confirmed prior to welding.

202 A weld repair analysis should be performed. Bending and tensile stresses shall be considered. The analysis shall determine the maximum excavation length and depth combinations that may be performed, taking into account all stresses acting at the area of the repair. The analysis shall be performed in accordance with Appendix A. The analysis shall consider the reduction of yield and tensile strength in the material due to the heat input from defect excavation, preheating, and welding and also dynamic amplification due to weather conditions and reduced stiffness effect at field joints. Elevated temperature tensile testing should be performed.

203 In case multiple welding stations on the installation vessel, the root and the first filler pass shall, as a minimum, be completed at the first welding station before moving the pipe. Moving the pipe at an earlier stage may be permitted if an analysis is performed showing that this can be performed without any risk of introducing defects in the deposited weld material. This analysis shall consider the maximum misalignment allowed, the height of the deposited weld metal, the possible presence of flaws, support conditions for the pipe and any dynamic effects.

204 For production testing, see App.C, G526-532.

E 300 Non-destructive testing

301 The extent of NDT for installation girth welds shall be 100% ultrasonic or radiographic testing. Radiographic testing shall be supplemented with ultrasonic testing in order to enhance the probability of detection and/or characterisation/sizing of defects.

302 For wall thickness > 25 mm, automated ultrasonic testing should be used.

303 Ultrasonic testing (UT) or automated ultrasonic testing (AUT) shall be used in the following cases:

- whenever sizing of flaw height and/or determination of the flaw depth is required (ref. Sec.5 D902).
- 100% lamination checks of a 50 mm wide band at ends of cut pipe.

304 When radiographic testing is the primary NDT method UT or AUT shall be used in the following cases:

- For the first 10 welds for welding processes with high potential for non-fusion type defects, when starting installation or when resuming production after suspension of welding
- to supplement radiographic testing for unfavourable groove configurations
- for wall thickness above 25 mm:
 - to provide additional random local spot checks during installation
 - to supplement radiographic testing to aid in characterising and sizing of ambiguous indications.

305 If ultrasonic testing reveals defects not discovered by radiography, the extent of ultrasonic testing shall be 100% for the next 10 welds. If the results of this extended testing are unsatisfactory, the welding shall be suspended until the causes of the defects have been established and rectified.

306 For “Golden Welds” (critical welds e.g. tie-in welds that will not be subject to pressure testing, etc.) 100% ultrasonic testing, 100% radiographic testing, and 100% magnetic particle testing or 100% liquid penetrant testing of non-ferromagnetic materials shall be performed. If the ultrasonic testing is performed as automated ultrasonic testing, see Appendix E, the radiographic testing may be omitted subject to agreement.

307 Magnetic particle testing or liquid penetrant testing of non-ferromagnetic materials shall be performed to verify complete removal of defects before commencing weld repairs, and for 100% lamination checks at re-bevelled ends of cut pipe.

308 Visual Examination shall include:

- 100% examination of completed welds for surface flaws, shape and dimensions
- 100% examination of the visible pipe surface, prior to field joint coating.

F. Pipeline Installation

F 100 General

101 The requirements of this subsection are generally applicable to pipeline installation, regardless of installation method. Additional requirements pertaining to specific installation methods are given in the following subsections.

102 This section addresses the main installation methods. Other installation methods may be suitable in special cases. A thorough study shall be performed to establish the feasibility of the installation method and the loads imposed during installation. Such methods are subject to agreement in each case.

103 Interfaces shall be established with other parties that may be affected by the operations or may affect the operation. The responsibilities of all parties and lines of communication shall be established.

104 Handling and storage of pipes and materials on supply and laying vessels shall ensure that damage to personnel, pipe, coatings, assemblies and accessories are avoided. Slings and other equipment used shall be designed to prevent damage of product. Storage of pipes, in-line assemblies and other accessories shall be seafastened to withstand design loads. All material shipped for installation shall be recorded.

105 All material shall be inspected for damage, quantity and identification upon arrival. Damaged items shall be quarantined, repaired or clearly marked and returned onshore.

106 Pipes and in-line assemblies shall be inspected for loose material, debris and other contamination and cleaned internally before being added to the line. The cleaning method shall not cause damage to any internal coating.

107 A pipe tracking system shall be used to maintain records of weld numbers, pipe numbers, NDT, pipe lengths, cumulative length, anode installation, field joints, in-line assemblies and repair numbers. The system shall be capable of detecting duplicate records.

108 The individual pipes of the pipeline shall be permanent marked in accordance with the established pipe tracking system. The marking shall be suitable for reading by ROV. Means of monitoring possible pipeline rotation may be applied. If damaged pipes are replaced, any sequential marking shall be maintained.

109 In-line assemblies shall be handled and stored to avoid damage prior to joining to the line, and shall further be handled such that damage is avoided through tensioning system, pipe supports/rollers or ramp, whichever is relevant. Any pipeline rotation shall be controlled.

110 Any applied field joint coating shall meet the requirements in Sec.9.

111 The lay configuration and loads shall be controlled in order to ensure that these are within established design parameters during installation. The configuration and loads may be controlled by various means, and these shall be clearly described including allowable ranges for the specific installation. Redundancy is required.

Guidance note:

The lay configuration may typically be controlled by tension, stinger tip clearance and lay back distance/touch down monitoring. Depending on the installation vessel and pipeline, the preferred methods may alter.

---e-n-d---of---G-u-i-d-a-n-c-e---n-o-t-e---

112 Pipeline lay down point should be monitored continuously for operations that are critical or represent a risk for existing infrastructure.

113 Pipelay in congested areas, in the vicinity of existing installations and at pipeline and cable crossings, shall be carried out using positioning systems with required accuracy. Measures shall be taken to avoid damage to existing infrastructure. ROV should be used to continuously monitor such operations. ROVs shall be capable of operating under the seastates expected for the operation in question.

114 The pipeline shall be installed within the lay corridor. Deviations to the lay corridor shall be checked and verified or corrected before pipelaying continues.

115 In case a buckle detector is used, the buckle detector load chart shall be monitored. The buckle detector shall be retrieved and inspected if there is reason to believe that buckling can have occurred. If the inspection shows indications of buckling or water ingress, the situation shall be investigated and remedial action performed.

116 The position of pipeline including start up and lay-down shall be verified as within their respective target areas prior to departure of the lay vessel from site.

117 Prior to abandonment of the pipeline, all internal equipment except the buckle detector should be removed. All welds, including the abandonment and recovery head welds, shall be filled to a level that the pipe can be safely abandoned on and retrieved from the seabed, and shall be clearly defined in advance.

118 During abandonment, winch tension and cable lengths shall be monitored and the values shall be within the specified range during the operation. The connection at the end of the wire shall be easily recoverable independently of waves and current conditions.

119 After abandonment and prior to recovery the pipeline shall be surveyed over a length away from the abandonment and recovery head, sufficient to ensure that no damage has occurred.

120 Diving and underwater operations shall be performed in accordance with agreed procedures covering applicable requirements.

121 In the event of buckling a survey of the pipeline shall be performed before repair to establish the extent of damage and feasibility of the repair procedure. After completion of the repair, a survey shall be performed of the pipeline over a length sufficient to ensure that no further damage has occurred.

122 If loss or major damage to weight and corrosion coating or anodes and their cables/connectors are observed, repair shall be performed and inspected according to established procedures.

123 For temporary storage and transportation of linepipe, see Sec.8 F400.

124 Initiation of pipeline installation shall be performed using adequate start-up piles or anchors to ensure safe operations.

125 Lay down of the pipeline should be performed such that the pipeline is inside the lay corridor and with the desired approach angle.

F 200 Additional requirements for installation method S-Lay

201 The stinger and rollers shall be positioned to avoid exceeding any limit state for the pipeline, and to avoid damage to anodes or other attachments.

F 300 Additional requirements for installation method J-Lay

301 The consequences in case losing internal welding clamp inside pipeline shall be established and agreed.

F 400 Additional requirements for installation methods introducing significant plastic strains

401 Additional requirements of this subsection are applicable to pipeline installation by methods which give total single event nominal strain > 1.0% or accumulated nominal plastic strain > 2.0%.

402 Pipelines used for such installation methods shall meet the supplementary requirement, pipe for plastic deformation (P), see Sec.7 I300.

403 Adequate support of the pipestring shall be provided when loading the reel. Sufficient tension shall be applied during reeling in order to ensure that the successive layers on the reel are sufficiently tightly packed to prevent slippage between the layers, and to control the curvature. Tension shall be monitored. Adequate measures shall be taken to protect the coating during reeling. Vessel motion shall be controlled and within acceptable limits during onshore tie-in weld between stalks.

404 The curvature of the pipe, peaking and sagging, between the point of departure from the reel and entry into the straighteners shall not exceed the maximum values assumed in design and included in the fracture assessment of the girth welds as per Appendix A and validated in the material testing of the girth welded pipes.

405 Anodes should be installed after the pipe has passed through the straightener and tensioner. The electrical connection between anodes and pipe shall meet the specified requirements and shall be verified at regular intervals, see Sec.9.

F 500 Towing

501 Tows may be performed as:

- surface or near-surface tows, with the pipestring supported by surface buoys
- mid-depth tows, where the pipestring is towed well clear away from the seabed
- bottom tows, where the pipestring is towed in contact with, or close to, the seabed.

502 For surface tows, all aspects pertaining to the tow are subject to agreement in each case.

503 For bottom or near bottom tows, the pipeline route shall be surveyed prior to the tow and the route shall avoid rough seabed, boulders, rock outcrops and other obstacles that may cause damage to the pipeline, coating or anodes during the tow and installation. During bottom and near bottom tows, adequate monitoring with ROVs and of the pipeline position at critical phases is required. Satisfactory abrasion resistance of the pipeline coating shall be demonstrated. All aspects pertaining to bottom tows are subject to agreement in each case.

504 Launching of pipestrings shall be performed such that the pipestring is safe from damage and damage to the coating and anodes are avoided. If pipestrings are moored inshore awaiting the tow, adequate precautions shall be taken to avoid marine growth influencing pipestring buoyancy, weight and drag.

505 Notification of the tow shall be given to the relevant authorities, operators of subsea installations crossed by the towing route and users of the sea.

506 During the tow a standby vessel shall be present to prevent interference with the tow by third party vessels.

507 Tension in the towing line and the towing depth shall be kept within the specified limits during the tow. If required, ballasting or de-ballasting shall be performed to adjust the towing depth to the specified values.

508 Installation shall be performed by careful ballasting and de-ballasting. Care shall be exercised to prevent over-stressing of the pipestring. The use of drag chains during the installation is recommended. The installation operation shall be monitored by ROV.

F 600 J-tube pull-in of risers

601 Prior to pull-in of risers into J-tubes, the position of the J-tube, clamps and supports and riser shall be confirmed and evaluated with respect to assumptions made in the design. Potential damage shall be identified and counteractive measures taken if required.

602 Diameter, roundness and cleanness of the J-tubes shall be inspected by gauging pigs, pulling a test pipe or similar to prevent the pulling head and riser from jamming and to ensure that the J-tube is clear of debris and obstructions.

603 Entry of the pipeline into the bellmouth shall be continuously monitored, and the tension in the pull-in cable shall be within specified limits.

604 Upon completion of the J-tube pull-in, a survey shall be performed to confirm the position of the riser including supports etc. Potential damage shall be identified and counteractive measures taken if required.

F 700 Shore pull

701 The requirements of this subsection are applicable to the execution, inspection and testing of shore pull when pipestrings are pulled either from a vessel onto the shore, or vice versa.

702 Detailed requirements for the execution, inspection and testing of shore pull shall be specified, considering the nature of the particular installation site.

703 Cables, pulling heads and other equipment shall be dimensioned for the forces to be applied, including any overloading, friction and dynamic effects that may occur.

704 Measuring devices shall be used to control the integrity of the pipeline during execution of the shore pull. Continuous monitoring of the cable tension and pulling force shall be applied, and these shall be within allowable limits. Monitoring with ROVs may be needed.

705 The winches shall be equipped with wire tension and length indicators and recorders. All measuring equipment shall be calibrated, and an adequate amount of spares to ensure uninterrupted operation shall be provided.

706 It shall be documented that ROVs are able to operate under the seastate expected for the operation in question. The ROVs shall, if used, be equipped as found necessary to perform the work in a safely manner and controlled manner.

707 Measuring devices shall be used to control the integrity of the pipeline during execution of the shore pull. Continuous monitoring of the cable tension and pulling force shall be applied.

708 Satisfactory abrasion resistance of the pipeline coating shall be demonstrated for the installation conditions.

709 Installation of the pulling head shall be made in a manner that does not compromise the integrity of the pipeline and provides a secure connection.

710 Buoyancy aids may be used as a mean to keep pulling tension within allowable limits.

711 During the operation, continuous monitoring of cable tension and pulling force shall be performed. Monitoring with ROVs may be needed.

F 800 Buckle detection

801 The consequences of buckles shall be evaluated as part of the HAZID/HAZOP (see Sec.5 A300 and Sec.10 A300), and in agreement between Operator and Contractor.

Guidance note:

The assessment of the consequences will typically include recovery (e.g. in case wet buckle), availability of repair methods and time frames for repair. The consequences of a buckle not detected during installation will normally require inline repair methods which can have large schedule and cost impact. Detection of buckles during installation will have less schedule and cost impact.

---e-n-d---of---G-u-i-d-a-n-c-e---n-o-t-e---

802 Mitigation measures for consequences of buckles shall be based upon the outcome of the HAZID/HAZOP. Buckle detection in accordance with Table 10-1 below should be used.

Table 10-1 Buckle detection		
<i>Safety class</i>	<i>Buckle detection requirement</i>	<i>Additional requirements and consequence of buckle</i>
Low	Buckle detection continuously during laying	
Medium	Buckle detection not required	Improved control of parameters controlling the lay configuration required (e.g. lay tension, touch down point monitoring etc.) and consequence of possible buckle is found acceptable.
High	Buckle detection not required	Improved control of parameters controlling the lay configuration required (e.g. lay tension, touch down point monitoring etc.) and consequence of possible buckle is found unacceptable.

Guidance note 1:

Buckle detection may be ensured by a buckle detector or equipment providing similar degree of detection.

---e-n-d---of---G-u-i-d-a-n-c-e---n-o-t-e---

Guidance note 2:

The buckle detector (or equipment providing same degree of detect ability) shall be positioned in such a way that critical areas are monitored (normally a distance after the touch down point). If a buckle detector is used the diameter of the disc shall be chosen with regard to the pipeline diameter and tolerances on ovality, wall thickness, misalignment and internal weld bead.

---e-n-d---of---G-u-i-d-a-n-c-e---n-o-t-e---

803 In case the parameters controlling the lay configuration indicates that unacceptable configuration is experienced or other indications of buckle events, an inspection shall be performed. The inspection shall be carried out such that it can be confirmed that buckling has not occurred.

F 900 Operating limit conditions

901 The installation operation shall be classified as weather restricted operation or unrestricted operation, see Sec.4 C600. An unrestricted operation is a temporary condition or permanent condition.

902 For weather restricted operations, operating limit conditions shall be established and agreed.

903 The operating limit conditions shall be based on detailed load effect analyses, vessel station keeping capability, FMEA analysis or HAZOP study data, and shall refer to objective, critical values indicated by measuring devices. The operating limit conditions shall be referred to in the procedure for configuration control. Continuous monitoring and recording of the measuring devices required for control of the operating limit conditions shall be performed during all phases of installation activities.

904 If a systematic deviation between the monitored response and predicted response from a seastate is found this should be accounted for.

905 Start of weather restricted operations is conditional to an acceptable weather forecast. Uncertainty in the weather forecast shall be considered.

906 For weather restricted operations, planning of operation shall be based on an operational reference period. Further, the operational criteria shall account for uncertainties in both weather forecasts and monitoring of environmental conditions. Regular weather forecasts from a recognised meteorological centre shall be available onboard the lay vessel, and shall be supplemented by historical environmental data. Reference is made to DNV-OS-H101.

907 If the critical values are about to be exceeded, preparations for lay-down shall commence. If the critical condition is weather dependent only, and if weather forecasts indicate that the weather condition will subside, the lay-down may be postponed subject to agreement.

908 Decision to recover the pipeline shall be based on comparison of the actual seastate with the limiting seastate, together with weather forecasts.

F 1000 Spools and other in-line assemblies installed separately from pipeline

1001 In-line assemblies to be installed separately from the pipeline shall be sufficiently seafastened to ensure no damage is occurring during transportation.

1002 For operating limit conditions for such installations, see F900.

1003 Lifting operations above existing infrastructure on the seabed should be avoided. Safe lifting and installation zones shall be defined.

1004 In-line assemblies to be installed separately from pipeline shall be installed inside the pre-defined target areas and also within the pre-defined heading limitations, in all planes.

1005 Recommended practice for modeling and analysis of offshore lifting operations are given in DNV-RP-H103.

G. Post-lay Survey

G 100 General

101 An as-laid survey covering the complete submarine pipeline system shall be performed. This can be done either by continuous touch down point monitoring during pipe laying or by a separate survey. In case continuous touch-down monitoring is used, pipeline positioning shall be confirmed after completion of pipeline installation.

Guidance note:

Continuous touch down monitoring may not identify possible horizontal curve pull-out, and therefore positioning of pipeline have to confirmed after completion of installation activities.

---e-n-d---of---G-u-i-d-a-n-c-e---n-o-t-e---

102 An as-built survey covering the complete submarine pipeline system shall be performed. The as-built survey shall be performed after all work on the submarine pipeline system, including crossings, trenching, gravel dumping, artificial backfill, subsea assemblies, riser installation, final testing etc., are completed. The as-built survey of the installed and completed pipeline system is performed to verify that the completed installation work meets the specified requirements, and to document any deviations from the original design. The as-built survey shall include the corrosion protection system where potential damage to the coating and sacrificial anodes shall be documented.

103 Requirements to survey vessel, survey equipment, the extent of survey, tolerances for the as-laid pipeline, and the maximum acceptable length and gap height of free spans at various locations shall be defined.

G 200 Survey requirements

201 The as-laid survey should include the following:

- position and depth of the pipeline, including location of in-line assemblies, anchoring and protective structures, tie-ins, supports etc.
- identification and quantification of any free spans with length and gap height
- determination of position of start-up and lay down heads
- determination of the presence of debris
- video documentation of the submarine pipeline system.

Guidance note:

Where video coverage cannot be obtained due to environmental reasons, alternate methodologies should be utilised to ensure 100% coverage.

---e-n-d---of---G-u-i-d-a-n-c-e---n-o-t-e---

202 The as-built survey should include the following in addition to the requirements for as-laid survey:

- out of straightness measurements as applicable
- depth of cover or trench depth as applicable
- location of areas of damage to pipeline, coating and anodes
- location of any areas with observed scour or erosion along pipeline and adjacent seabed
- verification that the condition of weight coating (or anchoring systems that provide for on-bottom stability) is in accordance with the specification
- description of wreckage, debris or other objects which may affect the cathodic protection system or otherwise impair the pipeline
- video documentation of the submarine pipeline system.

Guidance note:

The survey accuracy should reflect the requirements related to lay corridor, size of lay down target boxes, restrictions in design related to out of straightness (in particular for uneven seabed) or other aspects that may influence pipeline integrity.

---e-n-d---of---G-u-i-d-a-n-c-e---n-o-t-e---

203 The pipeline horizontal position and seabed and pipeline vertical profile/seabed shall as a minimum be reported at intervals defined by the requirement for as-laid pipeline analyses. The data shall be reported in an agreed format.

G 300 Survey of corrosion protection systems

301 In the case of damage to coating or anodes, consequences for long-term performance shall be considered. Potential measurements at any bare surfaces should be carried out to confirm adequate corrosion protection. Corrective actions may include retrofitting of anodes and coating repairs. Satisfactory level of corrosion protection shall be documented after the corrective action has been performed.

302 Impressed current cathodic corrosion protection systems shall be inspected, including cables, conduits, anodes and rectifiers. Readings from the corrosion monitoring system shall be verified by independent potential measurements, and adequate electrical insulation from other installations (if applicable) shall be confirmed installed and commissioned according to ISO 15589-2 *Petroleum and natural gas industries - Cathodic protection of pipeline transportation systems - Part 2: Offshore pipelines*.

If the required protection level is not attained, the causes shall be identified and adequate corrective actions performed. Satisfactory performance shall be documented after the corrective action.

H. Post-lay intervention (Seabed intervention and Pipeline Protection)

H 100 General

101 The requirements of this subsection are applicable to free span rectification and the protection of pipelines, e.g. by trenching and backfilling, gravel dumping, grout bags, concrete mattresses etc.

102 A specific survey of the work area should be performed, or supplementing, the as-laid survey if:

- significant time has elapsed since the as-laid survey
- a change in seabed conditions is likely
- marine activity is present in the area
- new installations are present in the area
- the as-laid survey does not provide sufficient information.

103 The survey of the work area should as a minimum include:

- a video inspection of the pipeline to identify any areas of damage to pipeline, coating and anodes
- cross profiles of the pipeline and adjacent seabed at regular intervals
- depth profiles along the pipeline and the seabed at both sides of the pipeline
- any existing subsea installations.

The undisturbed seabed level shall be included in the cross profiles.

H 200 Span rectification and protection specification

201 The requirements applicable to the specific methods of span rectification and protection regarding execution, monitoring and acceptance criteria shall be documented. Requirements for vessels, survey equipment etc. shall be addressed in the installation and testing specifications and procedures. The extent of procedures to be prepared and qualified shall be specified.

H 300 Free span rectification

301 Free span rectification is required for all spans exceeding the specified acceptable length or height for the specific location. Rectification of other spans shall be considered if scour or seabed settlement could enlarge the span length and gap height above maximum acceptable dimensions before the first planned inspection of the pipeline.

302 Adequate rectification of free spans shall be documented by a video survey. All rectified free spans shall be identified and the length, gap and height shall be within the requirements.

H 400 Trenching

401 Where trench excavation is performed after pipelaying, the trenching equipment shall be of a type that does not place significant loads on the pipeline and minimises the possibility of damage to the pipeline.

402 Trenching equipment shall be equipped with sufficient instrumentation to ensure that damage and excessive pipe contact is avoided.

403 Special care shall be taken during trenching operations of piggy back / bundle pipelines, so that strapping arrangements will not be disturbed / damaged during trenching.

404 Trenching shall not damage or dismantle the anodes.

405 Where mechanical backfilling is required, it shall be carried out in a manner that minimises the possibility of damage or disturbance to the pipeline.

406 It shall be ensured that the trenching method for the given pipeline submerged weight and soil properties is adequate to avoid pipeline floatation during trenching and backfilling.

407 The trenching equipment monitoring system shall be calibrated and include:

- devices to measure depth of pipe
- a monitoring system and control system preventing horizontal loads on the pipeline or devices to measure and record all vertical and horizontal forces imposed on the pipeline by trenching equipment, and devices to measure the proximity of the trenching equipment to the pipeline, horizontally and vertically relative to the pipeline
- underwater monitoring systems enabling the trenching equipment operator to view the pipeline and seabed profile forward and aft of the trenching equipment
- measuring and recording devices for trenching equipment tow force
- devices monitoring pitch, roll, depth, height and speed of the trenching equipment.

408 Jet sleds shall have a control and monitoring system for the position of the jetting arms and the overhead frame, horizontally and vertically relative to the pipeline. The location of the sled shall not be controlled by the force between sled and pipeline. Devices indicating tension in the tow line and showing the depth of the trench shall be installed.

409 An allowable range of values, indicated by the measuring devices of the trenching equipment, shall be established. The possibility of damage to coating shall be considered. During trenching operations the measuring devices shall be continuously monitored.

410 A post-trenching survey should be performed after the trenching in order to determine if the required depth of trench and/or pipe has been achieved and if any remedial work is required.

H 500 Post-installation gravel installation

501 Material used for gravel installation shall meet the specified requirements for specific gravity, composition and grading.

502 Gravel installation shall be performed in a continuous and controlled manner. Existing infrastructure should not be disturbed or interfered with.

503 The gravel installation operation shall ensure rectification of all free spans to meet the specified requirements. Scouring effects shall be considered.

504 If the fall pipe technique is used for gravel installation, minimum clearances shall be specified such that the fall pipe cannot touch the pipeline or any other subsea installation or the seabed. Deployment operations shall be performed well away from the pipeline or any other subsea installation. Before the fall pipe is moved to the installation location, the clearance beneath the fall pipe shall be verified. The clearance shall be continuously monitored during gravel installation.

505 The completed gravel installation shall leave a mound on the seabed with a smooth contour and profile and a slope not steeper than specified.

506 If the gravel installation is performed over cable and pipeline crossings, the gravel mound shall provide the specified depth of cover over both the crossing and the crossed pipeline. During the gravel installation operations inspections shall be performed with a sonar survey system or with video when visibility is restored, to determine the completeness and adequacy of the installation.

507 Upon completion of the gravel installation, a survey shall be performed to confirm compliance with the specified requirements. The survey shall include:

- video of the pipeline length covered
- cross profiles of the mound and adjacent undisturbed seabed at regular intervals
- length profiles of the mound
- confirmation that minimum required buried depth is achieved
- confirmation that maximum burial depth is not exceeded
- any existing installations and their vicinity in order to ensure that the installation(s) have not suffered damage.

H 600 Grout bags and concrete mattresses

601 Concrete mattresses and grout bags shall meet the specification with regard to size, shape and flexibility of the material, location of filling points, and the specific gravity, composition and grading of grout.

602 Placing of grout bags and concrete mattresses shall be performed in a controlled manner, such that the bags or mattresses are placed as required. Restrictions on vessel movements during the operation shall be given.

603 During the placing operations, inspections shall be performed with a ROV-mounted video camera to determine the completeness and adequacy of the installation.

604 Upon completion of the placing operation, a survey shall be performed to confirm compliance with the specified requirements. The survey shall as a minimum include:

- video of the completed work
- cross profiles of the placed bags or mattresses and adjacent undisturbed seabed at regular intervals
- length profiles of the placed bags or mattresses and the seabed at both sides of the area.

I. Tie-in

I 100 General

101 The requirements of this subsection are applicable to tie-in operations using welding or mechanical connectors. The operations can be performed onboard a laying vessel (in which case welding is the preferred method) or underwater.

102 Tie-in operations by means of hot or cold taps are subject to special consideration and agreement.

103 Operating limit conditions with regard to the seastate, current and vessel movements shall be established. Uncertainty in weather forecast shall be considered.

I 200 Tie-in operations above water

201 The position of the tie-in shall be verified prior to start of operations. A survey shall be performed to establish that the location is free of obstructions and that the seabed conditions will permit the tie-in to be performed as specified.

202 Lifting and lowering of the pipeline sections shall be analysed to determine the critical parameters and operational criteria for the operation. Critical parameters/operational criteria shall be monitored continuously.

203 Lifting arrangements and equipment shall be designed taking into account the critical parameters and operational criteria for the operations.

204 The operation should be monitored to confirm correct configuration of the pipeline sections from the seabed and onto the vessel.

205 The alignment and position of the tie-in ends shall be within the specified tolerances before completing the tie-in.

206 Installation of mechanical connectors shall be performed in accordance with the Manufacturer's procedure. For flanged connections hydraulic bolt tension equipment shall be used. During all handling, lifting and lowering into the final position, open flange faces shall be protected against mechanical damage.

207 A leak test to an internal pressure not less than the local incidental pressure should be performed for all mechanical connections.

208 Corrosion protection of the tie-in area shall be performed and inspected in accordance with accepted procedures.

209 After completion of the tie-in, a survey of the pipeline on both sides of the tie-in, and over a length sufficient to ensure that no damage has occurred, should be performed

210 It shall be verified that the position of the tie-in is within the target area prior to departure of the vessel from site. The pipeline stability shall be ensured and adequate protection of pipeline provided.

211 Requirements for dry welding are given in Appendix C.

I 300 Tie-in operations below water

301 In addition to the requirements in Subsection I200, the requirements below are valid for tie-in operations involving underwater activities.

302 Diving and underwater operations shall be performed in accordance with agreed procedures for normal and contingency situations covering applicable requirements.

303 Requirements for underwater hyperbaric dry welding are given in Appendix C.

J. Pre-commissioning

J 100 General

101 All work on the submarine pipeline system, including crossings, trenching, gravel installation, artificial backfill, subsea assemblies, riser installation, tie-in, as-built survey etc., should be completed before pre-commissioning activities commences.

102 Disposal of cleaning and test fluids shall be performed in a manner minimising danger to the environment. Any disposal of fluids shall be in compliance with requirements from National Authorities.

103 Requirements for equipment, the extent of testing and preparation for operation, performance of tests and preparation for operation and associated acceptance criteria shall be defined. The extent of procedures to be prepared and qualified shall be specified.

104 All operations and tests shall be performed in accordance with agreed procedures.

J 200 Waterfilling, cleaning and gauging

201 Cleaning and gauging may be combined with the initial flooding of the pipeline, be run as a separate operation, or be combined with the weld sphere removal after completion of hyperbaric tie-in.

202 Appropriate measures shall be taken to ensure that any suspended and dissolved substances in the fluid used for cleaning operation are compatible with the pipe material and internal coating (if applied), and that deposits are not formed within the pipeline.

203 Filling of the submarine pipeline system with water should be performed in a controlled manner, using water behind one or more pigs. The pig(s) shall be capable of providing a positive air/water interface. Considerations shall be given to pre-filling valve body cavities with an inert liquid, unless the valves have provision for pressure equalisation across the valve seats. All valves shall be fully open during line filling. A pig tracking system and the use of back-pressure to control the travel speed of the pig shall be considered if steep gradients occur along the pipeline route.

204 Water to be used for flooding should have a minimum quality corresponding to filtration of 50µm, and suspended matters should not have an average content exceeding 20 g/m³.

205 If water quality or the water source is unknown, water samples shall be analysed and suitable actions shall be taken to remove and/or inhibit harmful substances.

206 If water is to remain in the pipeline for an extended period of time, consideration shall be given to control of bacterial growth and internal corrosion by chemical treatment (see Sec.6 D302).

207 Added corrosion inhibitors, any chemical additives like oxygen scavengers, biocides, dyes, etc. shall be considered for possible harmful interactions selected to ensure full compatibility and their impact on the environment during and after disposal of the test water shall be considered.

208 The submarine pipeline system shall be cleaned. The pipeline cleaning concept shall consider:

- protection of pipeline components and facilities (e.g. valves) from damage by cleaning fluids and pigs
- testing devices such as isolation spheres etc.
- removal of substances that may contaminate the product to be transported
- particles and residue from testing and mill scale
- organisms and residue resulting from test fluids
- chemical residue and gels
- removal of metallic particles that may affect future inspection activities.

209 Acceptance criteria for cleaning shall be established and agreed.

210 The submarine pipeline system shall be gauged. The main purpose of gauging the submarine pipeline system is to prove that it is unlikely that any damages, dent or buckle exists in the submarine pipeline system, and to provide basis for future operational pigging activities. The purpose is further to document that no excessive ovalisation exceeding the requirements in Sec.5, D1100 has taken place. The preferred gauging is by an “intelligent” gauging tool (calliper pig). As an alternative a running a pig with a metallic gauge plate with a diameter of 95% of the largest nominal inner diameter, or 97% of the minimum inner diameter of the largest nominal inner diameter. In case a gauge plate cannot be used due to internal restrictions (e.g. variations in diameter, valves, bends etc.) an “intelligent” gauging tool (calliper pig) shall be used. When gauging is carried out with an intelligent tool the tolerances of the diameter measurements should be less than 0.2 mm and the diameter readings should be made minimum each 10mm along the entire pipeline length. The tool shall also be able to report locations of the readings.

Guidance note:

The minimum inner diameter including uncertainties can be established as:

$$D_{\min,\text{tot}} = D_{\min}(1-f_0/2) - 2t_{\max} - 2h_{\text{bead}}$$

Where h_{bead} also allows for possible misalignment.

---e-n-d---of---G-u-i-d-a-n-c-e---n-o-t-e---

211 Cleaning and gauging train design including number and type of pigs, train velocity shall be decided based upon need for chemical cleaning, type and length of pipeline, steep gradients along the pipeline route, type of service, construction method, downstream process, potential cleaning and gauging already performed (see in Sec.8 F504 and Sec.8 G101) or other aspects.

212 For cleaning operations where the acceptance criteria for cleaning are not fulfilled, a rerun of the cleaning pig train should be performed.

213 If cleaning is performed on separate sections of the submarine pipeline system prior to tie-in, a minimum of one cleaning pig should be run through the completed submarine pipeline system prior to, or during, product filling.

214 On completing of all tie-ins, a calliper pig or gauge plate should be run through the submarine pipeline system.

J 300 System pressure testing

301 A pipeline system pressure test shall be performed based upon the system test pressure determined according to Sec.5 B202 unless the test is waived as allowed by Sec.5 B203. The complete submarine pipeline system should be tested.

302 The submarine pipeline system may be tested as separate sections provided that the tie-in welds between sections fulfil the requirements in E306.

303 The pipeline section under test shall be isolated from other pipelines and facilities. Pressure testing should not be performed against in-line valves, unless possible leakage and damage to the valve is considered, and the valve is designed and tested for the pressure test condition. Blocking off or removal of small-bore branches and instrument tappings, should be considered to avoid possible contamination.

304 Temporary testing equipment such as end closures, temporary pigtraps and manifolds, shall be designed and constructed according to a recognised code and with design pressure equal to the pipeline design pressure.

Such items shall be individually pressure tested to at least the same test pressure as the pipeline.

305 Instruments and test equipment used for the measurement of pressure, volume and temperature shall be calibrated for accuracy, repeatability and sensitivity. All instruments and test equipment shall possess valid calibration certificates, with traceability to reference standards within the 6 months preceding the test. If the instruments and test equipment have been in frequent use, calibration specifically for the test should be performed.

306 Gauges and recorders shall be checked for correct function immediately before each test. All test equipment shall be located in a safe position outside the test boundary area.

307 The test pressure shall be measured using a dead weight tester or a high accuracy pressure transducer, in addition to a high accuracy large diameter pressure gauge. Dead weight testers shall not be used before a stable condition is confirmed, and shall not be used offshore when positioned on a vessel. If a high accuracy pressure transducer is used, it shall have similar accuracy as a dead weight tester. Time history of the test pressure shall be recorded.

308 The following requirements apply for instruments and test equipment:

- dead weight testers shall have a range of minimum 1.25 times the specified test pressure, and shall have an accuracy better than ± 0.1 bar and a sensitivity better than 0.05 bar
- the volume of water added or subtracted during a pressure test shall be measured with equipment having accuracy better than $\pm 1.0\%$ and sensitivity better than 0.1%
- temperature measuring instruments and recorders shall have an accuracy better than $\pm 1.0^\circ\text{C}$, and a sensitivity better than 0.1°C
- pressure recorders and temperature recorders shall be used to provide a graphical record of the pressure test continuously for the total duration of the test.

309 A correlation that shows the effect of temperature changes on the test pressure where relevant, shall be developed and accepted prior to starting the test. Temperature measuring devices, if used, shall be positioned close to the pipeline, and the distance between the devices shall be based on temperature gradients along the pipeline route.

310 The test medium should be water meeting the requirements given in J200.

311 The air content of the test water shall be assessed by constructing a plot of the pressure against volume during the initial filling and pressurisation, until a definite linear relationship is apparent, see Figure 1. This should be done at 35 bar pressure. The assessed air content should not exceed 0.2% of the calculated total volume of the pipeline under test. If the limit is exceeded, it shall be documented that the amount of air, not will influence the accuracy of the test significantly.

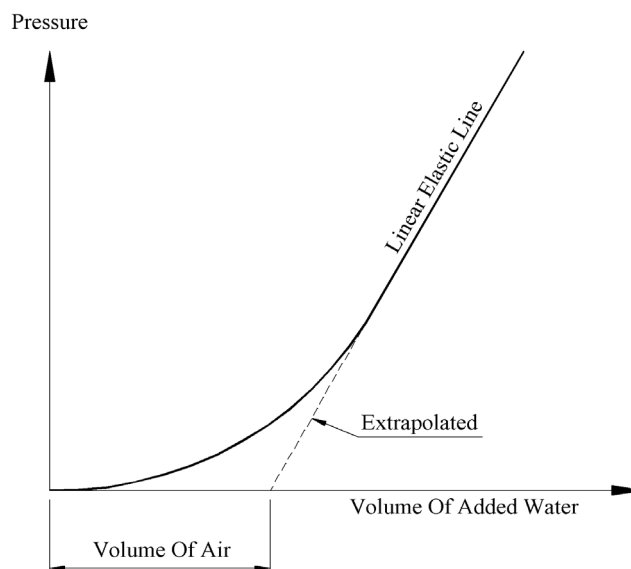

Figure 1
Determination of volume of air

312 Pressurisation of the submarine pipeline system shall be performed as a controlled operation with consideration for maximum allowable velocities in the inlet piping. The last 5% up to the test pressure shall be raised at a reduced rate to ensure that the test pressure is not exceeded. Time should be allowed for stabilisation

before the test hold period begins, in particular when testing operation occurs directly post flooding/flushing of the pipeline system. Stabilisation time shall be based on the filling water temperature difference with ambient temperature and on the possible presence of thermal insulation.

313 The pressure level requirement for the system pressure test is given in Sec.5 B203.

314 The test pressure hold period after stabilisation shall be held for a minimum 24 hours.

315 Subject to agreement shorter pressure hold periods may be accepted for pipelines with test volumes less than 5000 m³. In these cases the principles of Sec.7 G should apply.

316 The pressure and temperatures where relevant, shall be continuously recorded during the pressurisation, stabilisation and test hold periods.

317 Flanges, mechanical connectors etc. under pressure should be visually inspected for leaks during the pressure test, either directly or by monitors.

318 The pressure test is acceptable if the submarine pipeline system is free from leaks, and the pressure variation is within $\pm 0.2\%$ of the test pressure. A pressure variation up to an additional $\pm 0.2\%$ of the test pressure is normally acceptable if the total variation (i.e. $\pm 0.4\%$) can be documented to be caused by temperature fluctuations or otherwise accounted for. If pressure variations greater than $\pm 0.4\%$ of the test pressure are observed, the holding period shall be extended until a hold period with acceptable pressure variations has occurred.

Guidance note:

Corresponding criteria for flexible pipes are often less stringent. For a pipeline system comprising both rigid pipeline and flexible parts (e.g. flexible riser or flexible tail), an equivalent pressure variation criterion should be determined by weighing the criteria for the different parts w.r.t. the volume of water that they contain during the system pressure test.

---e-n-d---of---G-u-i-d-a-n-c-e---n-o-t-e---

319 De-pressurisation of the submarine pipeline system shall be performed as a controlled operation with consideration for maximum allowable velocities in the pipeline and the discharge piping.

J 400 De-watering and drying

401 De-watering should be performed before introducing the product fluid into the pipeline. Drying may be required in order to prevent an increase in the corrosion potential or hydrate formation, or if omission of drying is deemed to have an adverse effect on the product transported.

402 In case the product fluid is introduced prior to de-watering the separation pig train between the test medium and the fluid shall be qualified in order to avoid contact between the residual test water and the product.

403 Selection of de-watering and drying methods and chemicals shall include consideration of any effect on valve and seal materials, any internal coating and trapping of fluids in valve cavities, branch piping, instruments etc.

J 500 Systems testing

501 Prior to fluid product filling, safety and monitoring systems shall be tested in accordance with accepted procedures. This includes testing of:

- corrosion monitoring systems
- alarm and shutdown systems
- safety systems such and pig trap interlocks, pressure protection systems etc.
- pressure monitoring systems and other monitoring and control systems
- operation of pipeline valves.

K. Documentation

K 100 General

101 The documentation of the offshore construction including testing of the submarine pipeline system shall be as a minimum include that given in Sec.12.

L. Installation manual

L 100 Installation manual

101 Installation manual is defined as a document or collection of documents required for performing the project specific installation work including normal operations and contingency handling/operations and acceptance criteria. In case the installation manual is a collection of documents, a master document shall be prepared.

Guidance note:

The installation manual is prepared in order to demonstrate that methods and equipment used by the Contractor will meet specified requirements, and that the results can be verified. The installation manual will hence include all factors that influence quality, reliability and safety of the installation work, including normal and contingency situations, and will address all installation steps, including examinations and check points. The manual will reflect the results of the risk management studies performed for the installation and will state requirements for the parameters to be controlled and the allowable range of parameter variation during the installation.

---e-n-d---of---G-u-i-d-a-n-c-e---n-o-t-e---

102 The installation Contractor shall prepare an installation manual.

Guidance note:

In case several Contractors are used, the installation manuals shall be harmonised. A master installation manual may be required.

---e-n-d---of---G-u-i-d-a-n-c-e---n-o-t-e---

103 The installation manual shall be agreed between Contractor and Operator, and updated and revised as found necessary.

104 The installation manual shall contain documentation of fulfilment of all requirements in Sec.10.

105 The installation manual shall include the following:

- quality system manual
- mobilisation manual
- construction manual
- health, safety and environment manual
- emergency preparedness manual.

106 The installation manual shall cover:

- organization, communications and reporting
- navigation and positioning, including anchors and anchor handling or dynamic positioning
- installation procedures (see L200)
- pre-commissioning procedures (see L300)
- contingency procedures (see L400)
- spread, including modifications and upgrading, if any
- pipeline configuration monitoring, positioning and control activities, including recording and reporting
- operating limit conditions imposed by environmental loads
- installation analyses including fatigue forming the basis for the operating limit conditions
- installation of in-line assemblies
- operations in areas of particular concern
- limitations imposed by structural strength in accordance with the design
- qualification of personnel
- essential variable including acceptable limits.

Guidance note 1:

Areas of particular concern may typically include shipping lanes, existing or future subsea installation, shore approach or crossings.

---e-n-d---of---G-u-i-d-a-n-c-e---n-o-t-e---

Guidance note 2:

For towing operations the installation manual shall typically include a description of towing vessel(s) including capacities, equipment and instrumentation.

---e-n-d---of---G-u-i-d-a-n-c-e---n-o-t-e---

107 Essential variables and their acceptable limits shall be established for cases where variations in manner of performance of an activity may give undesirable results. Essential variables shall as minimum be established for:

- Allowable variations in configuration control parameters where variations beyond established limits may cause critical conditions during installation
- variations in equipment settings/performance that can cause or aggravate critical conditions
- changes in welding joint design and process parameters beyond that allowed in Appendix C
- changes in NDT method, NDT equipment and NDT equipment calibration beyond that allowed in Appendix D and Appendix E
- weld repair lengths/depths in areas where the pipe is subject to bending moments/axial stress. The maximum length/depth of excavation shall be determined by stress analyses
- field joint coating procedure

- operating limit conditions
- any other requirement due to the nature of the operations.

108 The validity of the installation manual is limited to the lay-vessel/spread where the qualification was performed and to the pipeline or section of pipeline in question.

L 200 Installation procedures

201 The installation Contractor shall prepare installation procedures.

Guidance note:

In case several Contractors are used, the installation procedures shall be harmonised.

---e-n-d---of---G-u-i-d-a-n-c-e---n-o-t-e---

202 The installation procedures shall be agreed between Contractor and Operator, and updated and revised as found necessary.

203 The installation procedures shall describe the following:

- purpose and scope of the activity
- responsibilities
- materials, equipment and documents to be used
- how the activity is performed in order to meet specified requirements and acceptance criteria
- how the activity is controlled and documented.

204 The installation procedures shall cover all requirements in Sec.10.

205 The following procedures shall be established:

- emergency procedures
- mobilisation procedures
- operational procedures covering all phases of installation work
- verification procedures
- welding and NDT equipment and procedures including repair
- pipe and equipment handling and lifting, hauling, stacking and storage procedures
- pipe tracking procedures
- pre-commissioning and commissioning procedures.

Guidance note:

Operational procedures may typically include configuration and alignment control, anchor handling, field joint coating, tensioning handling, ROV control, anode attachment, control of weight and buoyancy distribution, control of pipe rotations, installation of in-line assemblies, loading and spooling pipe onto the reel, pipe straightening and underwater operations.

---e-n-d---of---G-u-i-d-a-n-c-e---n-o-t-e---

L 300 Pre-commissioning procedures

301 The installation Contractor shall prepare pre-commissioning procedures.

Guidance note:

In case several Contractors are used, the pre-commissioning procedures shall be harmonised.

---e-n-d---of---G-u-i-d-a-n-c-e---n-o-t-e---

302 The pre-commissioning procedures shall be agreed between Contractor and Operator, and updated and revised as found necessary.

303 The pre-commissioning procedures shall be prepared for the pre-commissioning activities of the submarine pipeline system, covering all testing activities that may be performed. The testing shall be conducted to verify that the submarine pipeline system meet the requirements of this standard. The pre-commissioning procedures shall contain sufficient detail to enable full understanding of testing methods and procedures, including acceptance criteria. It shall also provide references to relevant specifications, test plans and engineering documents applicable for the submarine pipeline system.

304 The pre-commissioning procedures shall state the type and extent of verification, testing, acceptance criteria, records, documentation and certification required for the components of the submarine pipeline system. It shall also provide references to relevant specifications, test plans and engineering documents applicable for the pipeline system.

L 400 Contingency procedures

401 The installation Contractor shall prepare contingency procedures.

Guidance note:

In case several Contractors are used, the contingency procedures shall be harmonised.

---e-n-d---of---G-u-i-d-a-n-c-e---n-o-t-e---

402 The contingency procedures shall be agreed between Contractor and Operator, and updated and revised as found necessary.

403 Contingency procedures shall be prepared for all installation activities.

Guidance note 1:

Contingency procedures may typically include failure of dynamic positioning system, failure of anchors or anchor lines, coating repair, anode repair, failure of tensioning system, ROV breakdown, breakdown of positioning system, weather conditions in excess of operating limit conditions, third party marine activity and critical or emergency situations identified in FMEA or HAZOP studies.

---e-n-d---of---G-u-i-d-a-n-c-e---n-o-t-e---

Guidance note 2:

For installation methods introducing plastic strains restrictions to potential contingency cyclic plastic loading shall be described.

---e-n-d---of---G-u-i-d-a-n-c-e---n-o-t-e---

SECTION 11 OPERATIONS AND ABANDONMENT

A. General

A 100 Objective

101 This section provides minimum requirements for the safe and reliable operation of submarine pipeline systems for the whole service life with its main focus on the pipeline integrity management system and the pipeline integrity management process.

102 Recommended practice for integrity management of submarine pipeline systems is given in DNV-RP-F116.

A 200 Scope and application

201 The integrity management system comprises a core integrity management process and a number of support elements (see Figure 1 and C100).

INTEGRITY MANAGEMENT SYSTEM

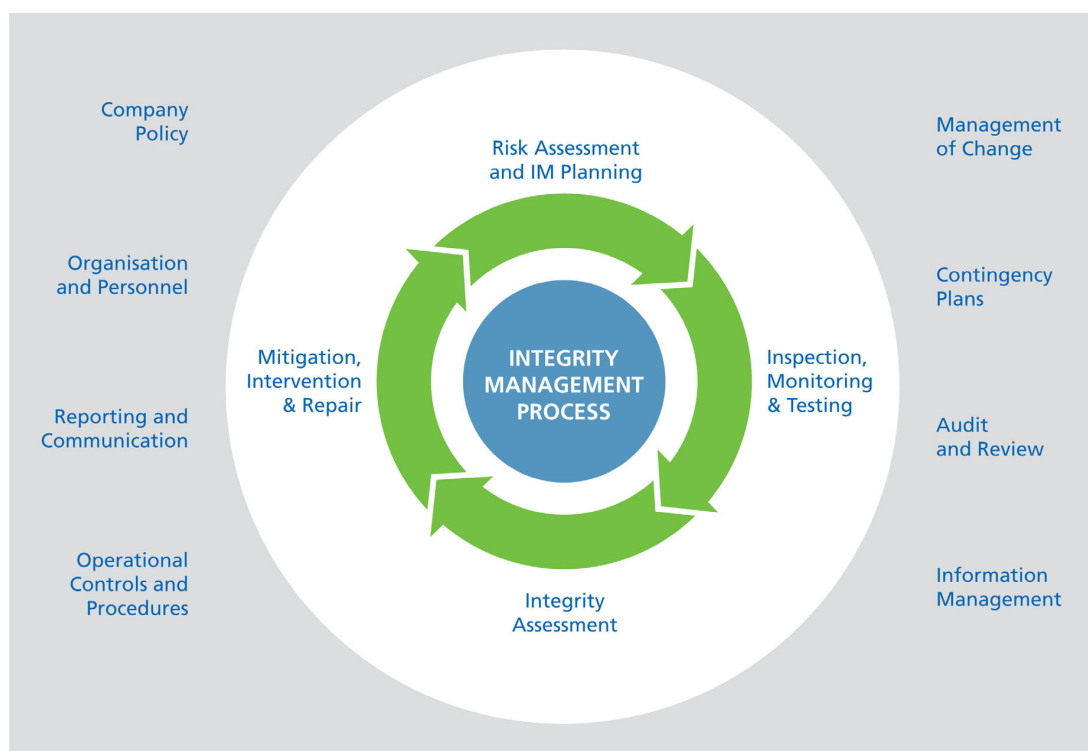

Figure 1
Integrity management system

202 The core pipeline integrity management process is the combined process of threat identification, risk assessments, planning, monitoring, inspection, maintenance etc. to maintain pipeline integrity.

203 Operating safely is interpreted as operating to meet the limit state criteria as established in design and updated through the project phases and service life.

204 The PIM principles and methodology are applicable to pipeline systems in general.

A 300 Systematic review of risks

301 The overall requirement to systematic review of risks in Sec.2 is complied with through the Risk Assessment and Integrity Management (IM) Planning activity that is part of the integrity management process – see A202 and D200.

A 400 Responsibilities

401 Pipeline integrity management is the responsibility of the Pipeline Operator. The Pipeline Operator needs to ensure that the integrity of the pipeline is not compromised.

402 At all times during the operational life of the pipeline system, responsibilities must be clearly defined and allocated.

A 500 Authority and pipeline operator requirements

501 The relevant national requirements shall be identified and ensured that they are complied with.

502 The relevant Pipeline Operator requirements should be complied with when planning and performing pipeline integrity management activities.

A 600 Safety philosophy

601 The safety philosophy adopted in design, and consistent with Sec.2, shall apply.

602 Design and operating premises and requirements shall be identified prior to start of operation and updated during the service life. These premises and requirements may be linked to:

- pressure, temperature and flow rate
- fluid composition (content of water, CO₂, H₂S etc.)
- sand
- cover depths
- free spans length and height
- pipeline configuration (e.g. snaking)
- others.

A change in design basis will in general require a re-qualification, see E.

603 It shall be verified that design and operating premises and requirements are fulfilled. If this is not the case, appropriate actions shall be taken to bring the pipeline system back to a safe condition.

604 A risk based pipeline integrity management philosophy, which takes into account both probability of failure and consequence of failure, should be applied.

B. Commissioning

B 100 General

101 Commissioning is the set of activities associated with the initial filling of the pipeline system with the fluid to be transported, and is part of the operational phase. Documentation and procedures for commissioning are specified in Sec.12 E.

102 This sub-section shall also apply for pipeline re-commissioning.

B 200 Fluid filling

201 During fluid filling, care shall be taken to prevent explosive mixtures and, in the case of gas or condensate, to avoid hydrate formation. The injection rate shall be controlled so that pressure and temperature do not exceed allowable limits (as given in design or re-qualification) for the pipeline material or dew point conditions.

B 300 Operational verification

301 After stable production has been reached it shall be verified that the operational limits are within design conditions. Important issues can be:

- flow parameters (pressure, temperature, etc.)
- CP-system
- expansion
- movement
- lateral snaking
- free span and exposure.

302 Scheduling of the first inspection of the wall thickness for pipelines designed for inspection pigging shall be evaluated based on the

- corrosivity of the fluid
- expected operational parameters
- robustness of the internal corrosion protection system (inhibitor system)
- corrosion allowance used in the design
- effectiveness of the QA/QC system applied during fabrication and construction, and
- defect sizing capabilities of the inspection tool that will be used during operation of the pipeline.

C. Integrity Management System

C 100 General

101 The Pipeline Operator shall establish and maintain an integrity management system which complies with relevant authority requirements (see A500) and includes the following elements as a minimum (see Figure 1):

- Pipeline Operator policy
- organisation and personnel
- management of change
- operational controls and procedures
- contingency plans
- reporting and communication
- audit and review
- information management
- the integrity management process (see D).

The core of the integrity management system is the integrity management process. The other elements mainly support this core process.

102 Documents for the operational phase are specified in Sec.12.

103 Specification of work processes should be the basis for definition of procedures.

104 The detailed procedures for operation, inspections and repairs shall be established prior to start-up of operation.

105 Procedures covering non-routine or special activities, shall be prepared as required, e.g. in case of major repairs, modifications etc.

C 200 Pipeline operator policy

201 The Pipeline Operator policy for pipeline integrity management should set the values and beliefs that the Pipeline Operator holds, and guide people in how these are to be realized.

C 300 Organisation and personnel

301 The roles and responsibilities of personnel involved in integrity management of the pipeline system shall be clearly defined.

302 Responsibility interfaces between different organisation units is particularly important. Such interfaces shall be managed and important areas that need to be handled are:

- well defined battery limits
- government regulatory responsibilities and statutory regulations
- emergency response, including contingency planning and responding to emergencies.

303 Training needs shall be identified and training shall be provided for relevant personnel in relation to management of pipeline integrity.

C 400 Management of change

401 Modifications of the pipeline system shall be subject to a management of change procedure that must address the continuing safe operation of the pipeline system. Documentation of changes and communication to those who need to know is essential.

402 If the operating conditions are changed relative to the design premises, a re-qualification of the pipeline system according to sub-section E shall be carried out.

C 500 Operational controls and procedures

501 Relevant operational controls and procedures are:

- start-up and shutdown procedures
- cleaning and other maintenance, e.g. pigging
- corrosion control
- monitoring
- safety equipment and pressure control system.

502 Measures shall be in place to ensure that critical fluid parameters are kept within the specified design limits. As a minimum, the following parameters should be controlled or monitored:

- pressure and temperature at inlet and outlet of the pipeline
- dew point for gas lines
- fluid composition, flow rate, density and viscosity.

503 All safety equipment in the pipeline system, including pressure control and over-pressure protection devices, emergency shutdown systems and automatic shutdown valves, shall be periodically tested and inspected. The inspection shall verify that the integrity of the safety equipment is intact and that the equipment can perform the safety function as specified.

504 Safety equipment in connecting piping systems shall be subject to regular testing and inspection.

505 For pressure control during normal operations, see Sec.3 D200.

506 Operational control shall ensure that design temperature limits are not exceeded. If the design is based on a constant temperature along the whole route, control of inlet temperature will be sufficient. If the design is based on a temperature profile for the pipeline, additional measures may be required.

C 600 Contingency plans

601 Plans and procedures for emergency situations shall be established and maintained based on a systematic evaluation of possible scenarios.

C 700 Reporting and communication

701 A plan for reporting and communication to employees, management, authorities, customers, public and others shall be established and maintained. This covers both regular reporting and communication, and reporting in connection with changes, special findings, emergencies etc.

C 800 Audit and review

801 Audits and reviews of the pipeline integrity management system shall be conducted regularly.

802 The focus in reviews should be on:

- effectiveness and suitability of the system
- improvements to be implemented.

803 The focus in audits should be on:

- compliance with regulatory and Pipeline Operator requirements
- rectifications to be implemented.

C 900 Information management

901 A system for collection of historical data, an in-service file, shall be established and maintained for the whole service life, see Sec.12 A103 and Sec.12 F201. The in-service file will typically consist of documents, data files and data bases.

902 The in-service file, together with the DFI-resume, shall be the basis for future inspection planning.

903 The in-service file and the DFI-resume shall be easily retrievable in case of an emergency situation.

904 The documents, data and information shall be managed as described in Sec.12 F and 12 I.

D. Integrity Management Process

D 100 General

101 The integrity management process consists of the following steps (see Figure 1):

- a) Risk Assessment and IM Planning – Long term planning based on evaluations of threats and the condition of the pipeline system.
- b) Inspection, Monitoring and Testing – Plan, conduct and document such activities.
- c) Integrity Assessment - Integrity assessment using recognised methods and based on design data and operational experience.
- d) Mitigation, Intervention and Repair - Assess need for, and conduct if needed, intervention and repair activities and other mitigating actions.

This process shall be performed periodically within regular intervals.

102 The requirements for corrosion inspection and monitoring, and the capability of optional techniques, shall be evaluated at an early stage of pipeline system design.

Guidance note:

Pipelines and risers manufactured from Corrosion Resistant Alloys (CRA) do not normally require inspection and monitoring of internal corrosion. This must be evaluated in each particular case.

---e-n-d---of---G-u-i-d-a-n-c-e---n-o-t-e---

103 An inspection and monitoring philosophy shall be established, and shall form the basis for the detailed

inspection and monitoring program. The philosophy shall be evaluated every 5 to 10 years.

104 All inspection and monitoring requirements identified during the design phase as affecting safety and reliability during operation shall be covered in the inspection and monitoring program, see Sec.3 D100 and Sec.5 B300.

105 A special investigation shall be performed in case of any event which impairs the safety, reliability, strength or stability of the pipeline system. This investigation may initiate further inspections.

106 If mechanical damage or other abnormalities are detected during the periodic inspection, a proper evaluation of the damage shall be performed, which may include additional inspections.

D 200 Risk assessment and integrity management planning - evaluation of threats and condition

201 An assessment of relevant risks by using qualitative and/or quantitative methods shall be performed and used to develop long term plans/strategies for the different integrity management activities. Specific requirements associated to these activities with regard to such long term plans/strategies are found in D300 to D500.

202 Data from design and operation is the basis for such assessments.

203 Threats shall be systematically identified, assessed and documented throughout the operational lifetime. This shall be done for each section along the pipeline and for components. Examples of typical threats are:

- internal corrosion
- external corrosion
- free spans
- buckles
- impact damage.

A more thorough list of threats and related damages / anomalies is found in DNV-RP-F116.

204 A long term inspection programme reflecting the overall safety objective for the pipeline shall be established, and shall be maintained/updated on a regular basis. The following should be considered:

- operation conditions of the pipeline
- consequences of failure
- likelihood of failure
- inspection methods
- design and function of the pipeline.

The long term program shall state the philosophy used for maintaining the integrity of the pipeline system and will form the basis for the detailed inspection program in terms of inspection methods and intervals.

205 The long term inspection program shall cover the entire pipeline system according to the Pipeline Operator's equipment scope including pipeline and any components according to the definitions C291, C341 and C342 in Sec.1.

D 300 Inspection, monitoring and testing

External inspection / Pipeline configuration survey

301 A pipeline configuration survey is a survey to determine the position, configuration and condition of the pipeline and its components.

302 The start-up external inspections should be completed within one year from start of production, see B300. In case of significant increase in temperature, pressure or flow rate after this first inspection, the need of additional inspections should be considered.

303 A detailed external inspection plan including specifications for the inspections shall be prepared for each survey. The detailed inspection plan should be updated based on previous inspections as required.

304 Pipeline systems that are temporarily out of service shall also be subject to periodical survey.

305 External Inspection shall be carried out to ensure that the design requirements remain fulfilled and that no damage has occurred. The inspection program should, as a minimum, address:

- exposure and burial depth of buried or covered lines, if required by design, regulations or other specific requirements
- free spans including mapping of length, height and end-support conditions
- condition of artificial supports installed to reduce free span
- local seabed scour affecting the pipeline integrity or attached structures
- sand wave movements affecting the pipeline integrity
- excessive pipe movements including expansion effects
- identification of areas where upheaval buckling or excessive lateral buckling has taken place
- integrity of mechanical connections and flanges

- integrity of sub-sea valves including protective structure
- Y- and Tee connections including protective structure
- pipeline settlement in case of exposed pipeline, particularly at the valve/Tee locations
- the integrity of pipeline protection covers (e.g. mattresses, covers, sand bags, gravel slopes, etc.)
- mechanical damage to pipe, coatings and anodes
- major debris on, or close to, the pipeline that may cause damage to the pipeline or the external corrosion protection system
- leakage.

306 The risers shall be part of the long-term external inspection programme for the pipeline system. In addition to the generally applicable requirements for pipeline inspection, special attention shall be given to the following elements for riser inspections:

- riser displacement due to pipeline expansion or foundation settlement
- coating damage
- technique for corrosion control of any risers in closed conduits or J-tubes
- extent of marine growth
- extent of any previous damage due to corrosion
- integrity and functionality of riser supports and guides
- integrity and functionality of protecting structure.

307 The frequency of future external inspections shall be determined based upon an assessment of:

- authority and Pipeline Operator requirements
- degradation mechanisms and failure modes
- likelihood and consequences of failure
- results from previous inspections
- changes in the operational parameters
- re-qualification activity and results
- repair and modifications
- subsequent pipelay operation in the vicinity.

308 Critical sections of the pipeline system vulnerable to damage or subject to major changes in the seabed conditions i.e. support and/or burial of the pipeline, shall be inspected externally at short intervals, normally on an annual basis. The remaining sections should also be inspected, ensuring a full coverage of the entire pipeline system within a suitable period, normally not more than 5 years.

309 For risers contained in J-tubes filled with non-corrosive fluid, external inspection of external corrosion may not be required if adequate properties of the fluid is verified by periodic testing.

External inspection / Risers in the splash zone and the atmospheric zone

310 In the splash zone and in the atmospheric zone, damaged and/or disbonded coatings can cause severe corrosion damage. Risers carrying hot fluids are most vulnerable to such damage.

311 In the splash and atmospheric zones, visual examination of the coating should be performed in order to assess the needs for preventive maintenance. Besides visual indications of direct damage to the coating, effects such as rust discoloration and bulging or cracking of the coating are indicative of under-rusting. Coating systems which prevent close inspection of under-coating corrosion shall require special consideration.

312 The frequency of the external inspection in the splash zone of risers shall be determined based on the fluid category, the line pipe material, coating properties and any corrosion allowance.

External inspection / Pipelines and risers in the submerged zone

313 In the submerged zone, coating malfunctions are not critical unless they are combined with deficiency in the cathodic protection system.

314 To a large extent, inspection of external corrosion protection of pipelines and risers with sacrificial anodes can be limited to inspection of the condition of anodes. Excessive anode consumption is indicative of coating deficiencies, except close to platforms, templates and other structures where current drain may lead to premature consumption of adjacent pipe anodes.

315 Potential measurements on anodes, and at any coating damage exposing bare pipe metal, may be carried out to verify adequate protection. Electric field gradient measurements in the vicinity of anodes may be used for semi-quantitative assessments of anode current outputs.

316 For pipelines with impressed current cathodic protection systems, measurements of protection potentials shall, at minimum, be carried out at locations closest to, and most remote from, the anode(s).

317 A survey of the external corrosion protection system, should be carried out within one year of installation.

Internal inspection / In-line inspection

318 In-line inspection is carried out in order to confirm the integrity of the pipeline system, primarily by

means of in situ wall thickness measurements.

Guidance note:

Un-piggable pipelines are subject to separate evaluations and alternative methods.

---e-n-d---of---G-u-i-d-a-n-c-e---n-o-t-e---

319 In-line inspection should be carried out with a carrier tool (“inspection pig”) capable of inspecting the internal and external surface of the pipeline along its full circumference and length, or a critical part thereof.

320 The technique for detection of internal and/or external corrosion shall be selected based on considerations of fluid, linepipe material, diameter and wall thickness, expected form of damage, and requirements to detection limits and defect sizing capability. The latter shall be determined based on pipeline design and operational parameters.

321 Candidate operators of inspection tools should be required to document the capability of their systems with respect to detection limits and sizing of relevant corrosion defects (including localised corrosion at girth welds) for the pipe dimensions considered.

322 The frequency of in-line inspections shall be determined based on factors such as:

- authority and Pipeline Operator requirements
- likelihood and consequences of failure
- potential corrosivity of fluid
- potential for development of external corrosion at hot-spots such as riser(s) and landfall/onshore pipeline sections
- detection limits and accuracy of inspection system
- results from previous surveys and monitoring
- changes in pipeline operational parameters, etc.

See also B300.

323 Inspection by special internal tools may be used to detect external corrosion of risers and pipelines in all three zones (atmospheric / splash / submerged) including risers contained in J-tubes, if required.

Internal Corrosion Monitoring

324 The objective of monitoring internal corrosion is to confirm that the fluid remains non-corrosive or, more often, to assess the efficiency of any corrosion preventive measures, and accordingly to identify requirements for inspection of corrosion.

325 Corrosion monitoring as defined above does not normally give any quantitative information of critical loss of wall thickness. Although monitoring may be carried out as actual wall thickness measurements in a selected area, it cannot replace pipeline inspection schemes that cover the pipeline system, or section thereof, in its full length and circumference. On the other hand, inspection techniques for internal corrosion are not normally sensitive enough to replace monitoring.

326 The following major principles of corrosion monitoring may be applied:

- fluid analyses; i.e. monitoring of fluid physical parameters and sampling of fluid for chemical analysis of corrosive components, corrosion retarding additions or corrosion products
- corrosion probes; i.e. weight loss coupons or other retrievable probes for periodic or on-line determination of corrosion rates
- in-situ wall thickness measurements, i.e. repeated measurements of wall thickness at defined locations using portable or permanently installed equipment.

327 Techniques and equipment for corrosion monitoring shall be selected based upon:

- monitoring objectives, including requirements for accuracy and sensitivity
- fluid corrosivity and the corrosion preventive measures to be applied
- potential corrosion mechanisms.

328 A typical major objective of corrosion monitoring is to detect changes in either intrinsic corrosivity of the fluid, or in the efficiency of the corrosion prevention measures. For pipelines carrying dry (i.e. fully processed) gas, inspection of internal corrosion may be postponed provided that monitoring demonstrates that no corrosive liquids have entered the pipeline, or been formed by condensation downstream of the inlet.

Testing

329 Testing activities may be specified to be carried out during the operational phase. Such activities shall be planned, executed, reviewed and documented. Testing activities may e.g. comprise:

- system pressure testing
- hydrostatic testing
- gas or media testing
- shut-in testing.

Recommended practice for testing during operation is given in DNV-RP-F116.

D 400 Integrity assessment

401 Pipeline systems with unacceptable defects may be operated temporarily under the design conditions or reduced operational conditions until the defect has been removed or repair has been carried out. It must, however, be documented that the pipeline integrity and the specified safety level is maintained, which may include reduced operational conditions and/or temporary precautions.

402 When a defect is observed, an evaluation shall be performed including:

- quantify details of the defect
- identify cause of defect
- evaluate accuracy and uncertainties in the inspection results.

If the defect is not acceptable, then further evaluations include:

- options for continued operation of the pipeline system
- repair methods.

403 In each case a thorough evaluation of the defect and the impact on safety and reliability for the operation of the pipeline shall be performed. The requirements given in the following sections regarding required actions, e.g. grinding or replacement, may be waived if it can be documented that the specified safety level for the pipeline system is not impaired.

404 Defects that affect the safety or reliability of the pipeline shall either be removed by cutting out the damaged section of the pipe or repaired by local reinforcement. Alternatively, the pipeline may be permanently re-qualified to lower operational conditions see E and Sec.5, e.g. reduced pressure, which may allow for omitting repair.

Free spans

405 Recommended practice for free spanning pipelines is given in DNV-RP-F105.

Global buckling

406 If the design is based on controlled global buckling including plastic strains, the pipeline should be verified based on established design limits and conditions (curvatures, strains, bending moment). If unexpected global buckling occurs, utilisation of the pipeline should be evaluated based on relevant failure modes. Recommended practice for global buckling of submarine pipelines is given in DNV-RP-F110.

Grooves, gouges, cracks and notches

407 Sharp defects like grooves, gouges, and notches should preferably be removed by grinding or other agreed repair methods. For ground defects where all sharp edges are confirmed as removed, the defect can be regarded as a smooth metal loss defect, see D408.

Metal loss defects

408 Metal loss defects caused by e.g. corrosion, erosion, or grind repair shall be checked for capacity. Recommended practice for corroded pipelines is given in DNV-RP-F101.

Dents

409 A dent is defined as a depression which produces a gross disturbance in the curvature of the pipe wall. For dent acceptance criteria, see Sec.5 D1300.

D 500 Mitigation, intervention and repairs

501 Examples of mitigation, intervention and repairs are:

a) mitigation:

- restrictions in operational parameters (pressure, temperature, flow rate, fluid composition etc.)
- use of chemical injections.

b) intervention:

- rock dumping
- installation of pipeline protection
- trenching.

c) repairs:

- local reinforcement (clamps etc.)
- replacement of pipeline parts.

All mitigation, intervention and repairs shall be documented.

502 Repair and modification shall not impair the safety level of the pipeline system below the specified safety level.

503 All repairs shall be carried out by qualified personnel in accordance with agreed specifications and procedures, and up to the standard defined for the pipeline.

504 All repairs shall be tested and inspected by experienced and qualified personnel in accordance with agreed procedures. NDT personnel, equipment, methods, and acceptance criteria shall be agreed upon in accordance with Appendix D.

505 Depending upon the condition of the damage, a temporary repair may be accepted until the permanent repair can be carried out. If a temporary repair is carried out, it shall be documented that the pipeline integrity and safety level is maintained either by the temporary repair itself and/or in combination with other precautions.

506 Recommended practice for pipeline repair in general is given in DNV-RP-F113.

Repair of dents

507 A dent affecting a weld can result in cracks, and removal of the damaged portion of the pipe should be considered. The damaged part can be cut out as a cylinder, or repaired by installing a grouted repair clamp, or a full encirclement welded split sleeve or bolted clamp which is designed to take the full internal operating pressure

Repair of leaks

508 Prior to carrying out a permanent repair of any leak, the cause of the leak shall be established.

509 The most suitable method for repairing a leak in the pipe depends upon e.g. the pipe material, pipe dimensions, location of leak, load conditions, pressure and temperature. The following repair methods may be used:

- a) The damaged portion is cut out of the pipe as a cylinder and a new pipe spool is installed either by welding or by a mechanical connector.
- b) Clamps are installed, and tightness is obtained by either welding, filler material, friction or other qualified mechanical means.

510 Leaking flanges and couplings may be sealed by installing a seal clamp covering the leaking flange or coupling, increasing the bolt pre-load, or replacing gaskets and seals. Prior to increasing the pre-load in bolts, it shall be documented by calculation that no over-stressing occurs in bolts, flange or gasket/seals. In case the pre-load in the bolts is removed, e.g. due to changing of gasket, new bolts shall be used for the flange connection.

511 All repair clamps, sleeves, pipe spools, and mechanical connectors shall be qualified prior to installation and leak tested after installation.

Repair by welding

512 Repair welding procedures, equipment and welders shall be qualified as described in Appendix C.

513 Repair welding above water shall be carried out as described in Appendix C.

514 Underwater welding shall be carried out in a dry habitat, see Appendix C.

515 Repair welding may, in special cases, be carried out on pipelines while operating, depending on pipe material, pipe wall thickness, fluid type, pressure and temperature. It shall be documented that safety for carrying out the repair is acceptable, and a safety procedure shall be established.

516 All repair welds shall be subject to visual and non-destructive testing, see Appendix D. Following the repair, pressure testing may be required for the repaired section.

E. Re-qualification

E 100 General

101 The purpose of this section is to define re-qualification and to give requirements for re-qualification of pipeline systems.

102 Re-qualification is a re-assessment of the design under changed design conditions.

103 A re-qualification may be triggered by a change in the original design basis, by not fulfilling the design basis, or by mistakes or shortcomings having been discovered during normal or abnormal operation. Possible causes may be:

- a) preference to use this standard, e.g. due to requirements for higher utilisation for existing pipelines
- b) change of the premises:
 - environmental loads

- deformations
 - scour.
- c) change of operational parameters:
- pressure or temperature
 - fluid or fluid direction
 - corrosivity of the medium.
- d) deterioration mechanisms having exceeded the original assumptions:
- corrosion rate, either internal or external
 - dynamic responses, contributing to fatigue, which may be caused by lacking supports etc.
- e) extended design life.
- f) discovered damage:
- dents
 - damage to pipeline protection
 - weld defects
 - corrosion related defects
 - damage to anodes.

E 200 Application

201 Within the original design life, and without essential changes in the manner of employment (repair etc.), the standard under which the pipeline was built may apply when considering incidents, minor modifications or rectification of design parameters exceeded during operation. This standard and associated DNV codes may alternatively be used.

For major modifications or other instances not covered by the above paragraph this standard shall apply. For lifetime extensions, reference is also made to ISO/TS 12747, Norsok Y-002 and Norsok U-009.

Guidance note:

The same safety level shall apply for lifetime extensions of an existing pipeline as would apply for the design of a new pipeline. The reason for requiring use of this standard is in case the original standard used for design is less stringent than necessary to meet the target safety levels specified in this standard.

---e-n-d---of---G-u-i-d-a-n-c-e---n-o-t-e---

E 300 Safety level

301 A target safety level as defined in Sec.2 C500 shall apply for a re-qualification assessment.

302 Operational experience, e.g. change of operational conditions, inspection records and modifications, shall be considered in a re-qualification assessment.

E 400 System pressure test

401 System pressure testing may be required when:

- the original mill pressure test or system pressure test does not satisfy requirements according to this standard at the new design pressure
- a significant part of the pipeline has not been system pressure tested e.g. new pipeline section as part of a modification or repair campaign (for omission of system pressure test, see Sec.5 B203).

E 500 Deterioration

501 All relevant deterioration and damage mechanisms shall be evaluated. Typical mechanisms are:

- a) corrosion:
- external corrosion
 - internal corrosion.
- b) erosion
- c) accidental loads
- d) development of free spans
- e) fatigue
- f) settlement.

502 Sufficient reliability or safety measures shall be applied to account for the accuracy and uncertainties in the inspection results.

503 Accumulated damage experienced prior to the re-qualification shall be included in the evaluation.

E 600 Design criteria

601 The parameters that trigger the re-qualification and the implication of changes in these parameters on different design conditions shall be clearly identified and documented. For re-design of these design conditions, reference is made to Sec.5.

F. De-commissioning

F 100 General

101 De-commissioning is the set of activities associated with taking the pipeline temporarily out of service.

102 Pipeline de-commissioning shall be planned and prepared.

103 De-commissioning shall be conducted and documented in such a way that the pipeline can be re-commissioned and put into service again.

104 De-commissioning evaluation shall include the following aspects:

- relevant national regulations
- environment, especially pollution
- obstruction for ship traffic
- obstruction for fishing activities
- corrosion impact on other structures.

105 De-commissioned pipelines shall be preserved to reduce effect from degradation mechanisms.

106 Sub-section B shall apply for pipeline re-commissioning.

G. Abandonment

G 100 General

101 Abandonment of a pipeline system comprises the activities associated with taking the system / or part of the system permanently out of operation.

102 An abandoned pipeline can not be returned to operation.

103 Pipeline abandonment shall be planned and prepared.

104 Pipeline abandonment evaluation shall include the following aspects:

- relevant national regulations
- health and safety of personnel, if the pipeline is to be removed
- environment, especially pollution
- obstruction for ship traffic
- obstruction for fishing activities
- corrosion impact on other structures.

SECTION 12 DOCUMENTATION

A. General

A 100 Objective

101 This section specifies the minimum requirements to documentation needed for design, manufacturing / fabrication, installation, operation and abandonment of a pipeline system.

102 A Design Fabrication Installation (DFI) resumé, as described in H, shall be established with the main objective being to provide the operations organisation with a concentrated summary of the most relevant data from the design and construction (incl. pre-commissioning) phases (see B, C and D).

103 An in-service file containing all relevant data achieved during the operational phase of the pipeline system and with the main objective to systemise information needed for integrity management and assessment of the pipeline system shall be established and maintained for the whole service life (see F200).

104 For the design, fabrication and installation phase, all required documentation shall be reflected in a master document register (MDR).

105 The required documentation for all phases of the pipeline system's lifetime shall be submitted to the relevant parties for acceptance or information as agreed.

B. Design

B 100 Structural

101 A design basis for the pipeline system shall be established, including, but not limited to:

- safety objective
- pipeline system description incl. location, general arrangements, battery limits, inlet and outlet conditions
- functional requirements including field development restrictions, e.g. safety barriers and subsea valves
- requirements to repair and replacement of pipeline sections, valves, actuators and fittings
- project plans and schedule, including planned period of the year for installation
- design life including specification of start of design life, e.g. installation, final commissioning, etc.
- transport capacity and pipeline sizing data
- attention to possible code breaks in the pipeline system
- geometrical restrictions such as specifications of constant internal diameter, requirement for fittings, valves, flanges and the use of flexible pipe or risers
- pigging requirements such as bend radius, pipe ovality and distances between various fittings affecting design for pigging applications
- relevant pigging scenarios (inspection and cleaning)
- pigging fluids to be used and handling of pigging fluids in both end of pipeline including impact on process systems
- topographical and bathymetrical conditions along the intended pipeline route
- geotechnical conditions
- environmental conditions
- operational conditions such as pressure, temperature, fluid composition, flow rate, sand production etc. including possible changes during the pipeline system's design life
- principles for strength and in-place analysis
- corrosion control philosophy
- second and third party activities.

102 The purpose of the design documentation is to ensure a reliable pipeline system. The design shall be adequately documented to enable second and/or third party verification. As a minimum, the following items shall be addressed:

- pipeline routing
- physical and chemical characteristics of fluid
- materials selection
- temperature/pressure profile and pipeline expansion
- strength analyses for riser and riser supports
- all relevant strength and in-place stability analyses for pipeline
- relevant pipeline installation analysis
- risk analysis as applicable
- systematic review of threats in order to identify and evaluate the consequences of single failures and series

- of failures (see Sec.2 B300)
- corrosion control (internal and external)
- piggability
- installation and commissioning.

103 Drawings shall be provided for the fabrication and installation of the pipeline system, including but not limited to:

- pipeline route drawings including information on, e.g. seabed properties and topology, existing and future platforms, pipelines/cables, subsea well heads, ship lanes, etc.
- alignment sheets
- detailed pipeline crossing drawings
- platform layout drawings with risers, riser protection systems, loading zones, boat landing areas, rescue areas, etc. as applicable
- spool fabrication drawing
- other components within the pipeline system (connectors, pigging loops etc.)
- pipeline protection drawings
- riser and riser clamp fabrication drawings
- land ownership details.

B 200 Linepipe and pipeline components (including welding)

201 The following documentation shall be established:

- material manufacturing specifications
- welding and NDT specifications
- material take off/data sheets.

B 300 Corrosion control systems and weight coating

301 The following documentation shall be established, as applicable:

- cathodic protection design report, see Sec.6 D508
- anode manufacturing and installation specifications, see. Sec.9 D and E
- outline anode drawings
- linepipe coating application specifications
- field joint coating specification(s)
- coating field repair specification(s)
- concrete coating specification (if applicable)
- corrosion monitoring system specification
- material take off/data sheets.

Guidance note:

The cathodic protection design report shall pay attention to the landfall section (if any) and possible interaction with the relevant onshore CP-system.

---e-n-d---of---G-u-i-d-a-n-c-e---n-o-t-e---

B 400 Installation

401 The following documentation shall be established:

- Failure Mode Effect Analysis (FMEA) and HAZOP studies (see Sec.10)
- installation and testing specifications and drawings
- Welding Procedure Qualification (WPQ) records.

B 500 Operation

501 Decisions and parameters having an impact on the operational phase of the pipeline system such as:

- operation envelope
- external and internal inspection strategies incl. piggability, ROV surveys
- measuring points for in-situ wall thickness measurements, ER-probes, weight loss coupons, fluid monitoring etc.

shall be emphasised and documented in design.

502 As a minimum, the following documentation shall be established:

- pipeline integrity management strategy covering strategies for corrosion control, inspection and maintenance
- emergency response strategy
- emergency repair contingency strategy.

B 600 DFI-Resumé

601 The Design part of the DFI-resumé shall be established and in accordance with the requirements given in H.

C. Construction - Manufacturing and Fabrication

C 100 Linepipe and pipeline component

101 The documentation to be submitted for review prior to start or during start-up of manufacturing shall include, but not be limited to:

- Quality Plan (QP)
- Manufacturing Procedure Specifications (MPS) including test requirements and acceptance criteria
- Manufacturing Procedure Qualification Test (MPQT) results
- manufacturing procedures (e.g. hydrostatic testing, dimensional measurements, mechanical and corrosion testing etc.)
- Welding Procedure Specifications (WPS), including procedures for repair welding
- Welding Procedure Qualification (WPQ) records
- Non Destructive Testing (NDT) procedures
- Personnel qualification records (e.g. for welders and NDT operators)
- manufacturer's/fabricator's quality system manual.

102 The as built documentation to be submitted after manufacturing shall include, but not be limited to:

- Quality Control (QC) procedures
- Inspection and Test Plan (ITP)
- traceability procedure
- material certificates
- Manufacturing Procedure Specifications (MPS) including test requirements and acceptance criteria
- results from MPQT
- test procedures (e.g. hydrostatic testing, dimensional measurements, mechanical and corrosion testing etc.)
- mechanical test reports
- hydrostatic testing report
- weld log records
- consumable batch numbers
- welder certificates
- heat treatment records
- NDT procedures and records
- NDT operator certificates
- dimensional reports
- equipment calibration certificates/reports
- storage procedures
- release certificates
- pipe tally sheet
- complete statistics of chemical composition, mechanical properties and dimensions for the quantity delivered.

C 200 Corrosion control system and weight coating

201 The documentation to be submitted for review prior to start of manufacturing shall include, but not be limited to:

- application/manufacturing procedure specification, including inspection/test requirements and acceptance criteria, repairs, documentation, etc.
- documentation of materials and concrete mix design
- Procedure Qualification Trial (PQT) results
- Inspection and Testing Plan (ITP) with referenced procedures for inspection, testing and calibrations
- anode drawings.

202 The as built documentation to be submitted after manufacturing shall include, but not be limited to:

- application/manufacturing procedure specification, including test requirements and acceptance criteria, repairs, personnel qualification records, etc.
- material data sheets and certificates
- daily logs including production test records
- complete statistics of coating dimensions, weight and negative buoyancy for the each joint delivered
- repair log
- electrical resistance test log.

C 300 DFI-resumé

301 The Manufacturing / Fabrication part of the DFI-resumé shall be established and in accordance with the requirements given in H.

D. Construction - Installation and Pre-Commissioning

D 100 General

101 The documentation to be submitted for review prior to start of installation shall include, but not be limited to:

- installation procedures for pipelines, risers, spools and components including acceptance criteria, test certificates for equipment, qualification records for personnel (e.g. welding, coating), etc.
- installation procedures for protective structures (as mattresses etc.) and pipeline anchoring structures
- Installation Manuals (IM) procedures
- trenching specification
- intervention procedure
- survey procedure
- hydrotest procedures
- pre-commissioning procedure, incl. procedures for dewatering, cleaning, drying, flooding, mothballing, etc.
- filling of fluid procedures.

102 Documentation produced in connection with the pressure testing of the pipeline system shall include:

- pressure and temperature record charts
- log of pressure and temperatures
- calibration certificates for instruments and test equipment
- calculation of air content
- calculation of pressure and temperature relationship and justification for acceptance
- endorsed test acceptance certificate.

103 The as built documentation to be submitted after installation and pre-commissioning shall include, but not be limited to:

- survey reports
- updated drawings
- intervention reports
- pre-commissioning reports.

104 Records and documentations should include authorisations and permits to operate.

D 200 DFI-Resumé

201 The Installation (incl. pre-commissioning) part of the DFI-resumé shall be established and in accordance with the requirements given in H.

E. Operation - Commissioning

E 100 General

101 As a part of the commissioning (see Sec.11 B) the documentation made available shall include, but not be limited to:

- a) procedure and results from fluid filling operations with special emphasis on design parameters having an impact on the integrity of the pipeline system such as temperature, pressure and dew points
- b) procedures and results from operational verification activities (i.e. start-up inspection). Important parameters to document are typically:
 - expansion
 - movement
 - global buckling
 - wall thickness/metal loss.
- c) inspection plans covering the future external and internal inspections of the pipeline system.

F. Operation

F 100 General

101 In order to maintain the integrity of the pipeline system, the documentation made available during the operational phase shall include, but not be limited to:

- organisation chart showing the functions responsible for the operation of the pipeline system
- personnel training and qualifications records
- history of pipeline system operation with reference to events which may have significance to design and safety
- installation condition data as necessary for understanding pipeline system design and configuration, e.g. previous survey reports, as-laid / as-built installation drawings and test reports
- physical and chemical characteristics of transported media including sand data
- inspection and maintenance schedules and their records
- inspection procedure and results covering the inspection aspects described in Sec.11, including supporting records.

102 In case of mechanical damage or other abnormalities that might impair the safety, reliability, strength and stability of the pipeline system, the following documentation shall, but not be limited to, be prepared prior to start-up of the pipeline:

- description of the damage to the pipeline, its systems or components with due reference to location, type, extent of damage and temporary measures, if any
- plans and full particulars of repairs, modifications and replacements, including contingency measures
- further documentation with respect to particular repair, modification and replacement, as agreed upon in line with those for the construction or installation phase.

103 In case of re-qualification of the pipeline system (see Sec.11 E), all information related to the re-assessment process of the original design shall be documented.

F 200 In-Service file

201 The in-service file, as defined in Sec.11 C900 shall as a minimum contain documentation regarding:

- results and conclusions from the in-service inspections
- accidental events and damages to the pipeline system
- intervention, repair, and modifications
- operational data (fluid composition, flow rate, pressure, temperature etc.) affecting corrosion and other deterioration mechanisms.

G. Abandonment

G 100 General

101 Records of abandoned pipelines shall be available and shall include but not be limited to:

- details of abandoned pipelines on land including route maps, the size of the pipeline depth of burial and its location relative to surface features
- details of abandoned offshore pipelines, including navigation charts showing the pipeline route.

H. DFI Resumé

H 100 General

101 A Design Fabrication Installation (DFI) Resumé shall be prepared to provide information for operation of the pipeline system. The DFI resumé shall clearly show the limits of the submarine pipeline system.

102 The DFI Resumé shall reflect the as-built status of the pipeline system and shall provide information for preparation of plans for inspection and maintenance planning.

103 The DFI Resumé shall specify design and operating premises and requirements.

104 The DFI Resumé shall contain all documentation required for normal operation, inspections and maintenance and provide references to the documentation needed for any repair, modification or re-qualification of the pipeline system.

105 The preparation of the DFI Resumé shall be carried out in parallel, and as an integrated part, of the design, fabrication and installation phase of the project.

H 200 DFI resumé content

201 As a minimum, the DFI Resumé shall contain the below listed items:

System description

202 Shall include a description of the pipeline system including:

- final dimensions
- final operational parameters
- a table, for planning of future pigging operations, listing all components in the system from pigtrap to pigtrap. Key data like inner diameter (ID), bend radius and wall thickness (WT) should be included, as well as references to additional documentation / drawings.

Document filing system

203 Shall give an overview of as-built documentation including description of filing system and method.

Design Basis

204 Shall give a summary of the final design basis, on which engineering, fabrication and installation is based. Design parameters of key importance for the operation of the pipeline system should be emphasised. The following parameters are considered important for the operation of the pipeline system:

- design life and limitations
- design standards
- environmental conditions
- tabulated geotechnical parameters as used in design
- design pressure and temperature
- flow rate
- fluid composition
- corrosion allowance
- depth of cover
- material specifications, covering pressure containing equipment and structure
- CP-system (i.e. anode details)
- coating system
- fatigue design assumptions incl. free span criteria
- incidental pressure relief system
- flow control techniques and requirements.

Design

205 Shall include a design activity resumé, all engineering assumptions and assessments not listed in the design basis in addition to applicable deviations and non-conformances including a description of possible impact on the operational phase.

Construction - Fabrication

206 Shall include a manufacturing / fabrication activity resumé, reference to specifications, drawings etc., discussion of problem areas and any deviations from specifications and drawings of importance for the operational phase.

Construction - Installation

207 Shall include an installation activity resumé, reference to specifications, drawings etc., discussion of problem areas and any deviations from specifications and drawings of importance for the operational phase.

Construction - Pre-commissioning

208 Shall include a pre-commissioning activity resumé and any results from the pre-commissioning phase. All applicable deviations and non-conformances shall be listed including a description of possible impact on the operational phase.

Certificate and Authority Approval

209 Shall include a hierarchical overview of issued certificates, release notes and authority approvals with reference to items and nature of any conditional approvals. The certificates, release notes and authority approvals shall show unambiguous reference to applicable standards and documents, items covered, accepted deviations, certification activities and condition for certificates.

Surveys

210 Shall give all engineering assumptions and assessments drawn from the route and site surveys in addition to all applicable as-installed route drawings.

Inspection, Maintenance and Repair

211 Shall include an overview of:

- identified areas deemed to require special attention during normal operation of the pipeline system
- operational constraints

Deviations and Non-Conformances

212 Shall include a complete list of waivers, deviations and non-conformances with special emphasis on identified areas deemed to require special attention during normal operation of the pipeline system.

Selected Drawings

213 Shall include a complete as-built drawing list, including drawings from sub-vendors and contractors, with reference to the as-built filing system. Selected drawings from the design, fabrication and installation phase, as:

- drawings of special components
- alignment sheets
- as-installed route drawings

shall be included.

I. Filing of Documentation

I 100 General

101 Maintenance of complete files of all relevant documentation during the life of the pipeline system is the responsibility of the Pipeline Operator.

102 The DFI-resumé (see H200) and all documentation referred to in the DFI Resumé shall be filed for the lifetime of the system. This includes also documentation from possible major repair or re-construction of the pipeline system.

103 The engineering documentation not mentioned in I102 shall be filed by the Pipeline Operator or by the engineering Contractor for a minimum of 10 years.

104 Files to be kept from the operational phase of the pipeline system shall as a minimum include final in-service (F200) inspection reports from start-up, periodical and special inspections, condition monitoring records, and final reports of maintenance and repair.

SECTION 13 COMMENTARY (INFORMATIVE)

A. General

A 100 Objective

The objective of this section is to:

- give background information to the requirements in the standard
- give guidance reflecting good engineering practice.

The section is informative only, and some of the recommendations may not be founded on thorough work but engineering judgement only.

B. Safety and Design Philosophy

B 100 Safety class discussion

Safety class shall be specified for each part of the pipeline and for each phase. The classification shall be based on the requirements in Sec.2.

The safety class concept allows the owner some flexibility in terms of risk which is both a reasonable and rational approach, e.g. this allows the owner to differentiate between the design conservatism for a flow line with a 5 year design life and a trunk line with 40 years design life.

The main aspect when determining the safety class is the consequence, typically to people, environment and cost. Note that this consequence not necessarily is limited to failure of the considered pipeline itself, but also to its impact on the total exploration. One such example may be reduction in production if a water injection line or a system for waste water fails which from an isolated point of view could be defined as safety class low.

Another example is differentiation of temporary phases. A failure during installation, normally considered as safety class low, will have a significantly smaller consequence than a failure during a shut-down period of the pipeline, where both pollution and time for repair are significantly more expensive and time consuming. In case a wet buckle occurs during installation and the vessel does not have the capacity to hold or eventually retrieve the pipe, this may have large consequences as another vessel may have to retrieve the pipe, and hence this may call for a higher safety class than low.

However, the total safety may not always be increased by specifying a higher safety class. This may be the case when the most probable cause of failure would be draught of vessel, where the emphasis should be put on operating procedures and back-up. During such circumstances, it may not be required with a higher safety class.

The above clearly illustrates that Table 2-4 is for “Normal” classification only, as stated.

B 200 Structural reliability analyses

Structural reliability methods consider structural analysis models in conjunction with available information regarding the involved variables and their associated uncertainties. The reliability as assessed by reliability methods is not an objective physical property of the pipeline itself in the given operational and environmental condition, but rather a nominal measure of the reliability given a particular physical and probabilistic modelling and analysis procedure applied.

Structural reliability analysis is only one part of a total safety concept as gross errors are not included. A gross error is defined as a human mistake during the design, construction or operation of the pipeline that may lead to a safety level far below what is normally aimed for by use of a partial safety factor design format or specific reliability analysis. In the following only natural variability are discussed and the corresponding probabilities are referred to as *nominal* throughout this standard.

Nominal target reliabilities have to be met in design in order to ensure that certain safety levels are achieved. A probabilistic design check can be performed using the following design format:

$$P_{f,\text{calculated}} < P_{f,T}$$

$P_{f,\text{calculated}}$ is the calculated nominal probability of failure evaluated by a recognised (accepted) reliability method and $p_{f,T}$ is a nominal target value that should be fulfilled for a design to be accepted.

Acceptable nominal failure probabilities depend in general on the consequence and nature of failure, the risk of human injury, economic losses, social (political) inconvenience and the expense and effort required to reduce the failure probability. The target values were proposed in the SUPERB project by Professor Torgeir Moan and were based on implied failure probability within different design equations representing different risks as reflected by the safety class.

The target failure probability is expressed as annual failure probability which has been discussed in the industry. It shall be interpreted as “*probability that a failure occurs in the period of one year*”.

Failure statistics may be used as guidance on relative failure probability levels but only limited information about specific failure probability for SLS, ULS and FLS can be deduced from failure statistics. Structural (nominal) failure probability from a SRA is a nominal value and cannot be interpreted as an expected frequency of failure.

B 300 Characteristic values

In a LRFD format, so called characteristic values are used. These are often lower fractiles for strength and resistance, not always however, and upper fractiles for loads. Typical examples of these may be SMYS for the yield stress and 100-year waves for loads.

The characteristic value in the resistance formulas is a lower fractile and the expected yield stress is typically in the order of 8% higher. On commonly overlooked implication of this is that it is not allowed to replace the f_y based upon a certificate or test. Such a replacement requires a thorough reliability assessment.

C. Loads

C 100 Conversion of pressures

The pressure used in the design criteria is now the incidental pressure. The incidental pressure is normally defined as the pressure with an annual probability of exceedance of 10^{-2} .

The incidental pressure is reflected also in many other codes, referred to as incidental pressure or maximum pressure and allows typically pressures 10% above the design pressure to account for water hammer effect and other not permanent pressures.

The incidental pressure has been used as the characteristic pressure (for extreme functional loads) and is therefore used in all the limit states of this standard. This is in contradiction with many other codes that use the design pressure or the Maximum Allowable Operating Pressure. DNV has selected the incidental pressure based on structural reliability arguments; it is a more likely pressure in case of failure.

The definition of the incidental pressure is identical with the 2007 revision but the logic has been improved in describing the pressure, see Sec.3 D200.

The ratio between the incidental pressure and design pressure shall be determined based on the Pipeline Control and Safety System tolerances and capabilities to ensure that the local incidental pressure meets the given probability of being exceeded within a year. This will then include simulation of the hydraulics of the medium.

If the pressure cannot exceed the incidental pressure, e.g. full shut-in pressure is used as incidental pressure, the design pressure may be taken as equivalent to the incidental pressure, see Table 3-1.

Different systems may have different definitions of pressures, e.g. between topside and a pipeline system. When converting the defined pressures in one system to pressure in another system, the conversion shall be based on pressure having an annual probability of exceedance less than 10^{-2} . This pressure shall then be defined as the incidental pressure in the pipeline system. Determination of design pressure shall then be made based on the above principles.

For pipeline systems with a two peak annual extreme pressure distribution, special considerations are required. Reference is given to D600.

D. Design Criteria

D 100 General

The basis for most of the given limit states were developed within the joint industry project SUPERB and the reports may be bought from Sintef, Norway. Some results have been published, e.g. Jiao (1996) and Mørk (1997).

The SUPERB results were incorporated in DNV Rules for Submarine Pipeline Systems, 1996 (DNV'96) and modified in order to allow for additional aspects, not necessarily to be considered in a research project. Hence, all limit states may not have identical partial factors as in the SUPERB reports.

In the 2000 revision of this standard, the LRFD format was modified on the resistance side as described in Sec.2 and the limit states from DNV'96 modified correspondingly. The local buckling formulation included some results from the Hotpipe project, allowing a higher utilisation of pressurised pipes, see e.g. Vitali (1999). In the 2007 revision, this was further improved to allow for higher utilisation for pressurised pipes. The characteristic pressure is now incidental pressure for all limit states.

D 200 Condition load effect factors

The load condition factor $\gamma_C = 1.07$, pipeline resting on uneven seabed refers to the load effect uncertainty due to variation in weight, stiffness, span length or heights. This implies that it is not applicable for the sag bend evaluation during installation on uneven seabed.

A γ_C lower than unity is used in DNV-RP-F110 for expansion and global buckling design to represent the degree of displacement control and uncertainties in, primarily, the pipe-soil properties.

D 300 Calculation of nominal thickness

The negative fabrication tolerance is normally given as a percentage of the nominal thickness for seamless pipes, and as an absolute measure for welded pipes.

The pressure containment criterion gives a minimum required minimum wall thickness, t_1 . Depending on the fabrication tolerance format, the implication of the corrosion allowance will be different. For a fabrication tolerance given as a percentage, % t_{fab} , Eq. (13.1) applies.

$$t = \frac{t_1 + t_{corr}}{1 - \%t_{fab}} \quad (13.1)$$

Correspondingly, the nominal thickness based on an absolute fabrication tolerance, t_{fab} , is given by Eq. (13.2).

$$t = t_1 + t_{corr} + t_{fab} \quad (13.2)$$

D 400 Pressure containment - equivalent format

The format of the pressure containment resistance in Sec.5 is given in a LRFD format. This corresponds to the traditional format, which usually is expressed in terms of allowable hoop stress, is given in Eq. (13.3).

$$(p_{li} - p_e) \frac{D - t_1}{2 \cdot t_1} \leq \frac{2 \cdot \alpha_U}{\sqrt{3} \cdot \gamma_m \cdot \gamma_{SC}} \cdot (SMYS - f_{y,temp}) \quad (13.3)$$

The differential pressure is here given as a function of the local incidental pressure. Introducing a load factor, γ_{inc} , reflecting the ratio between the incidental pressure and the design pressure, the formula can be rearranged for the reference point above water, as given in Eq. (13.4).

$$p_d \frac{D - t_1}{2 \cdot t_1} \leq \frac{2 \cdot \alpha_U}{\sqrt{3} \cdot \gamma_m \cdot \gamma_{SC} \cdot \gamma_{inc}} \cdot (SMYS - f_{y,temp}) \quad (13.4)$$

Introducing a usage factor as given in (13.5), the criteria can be given as in Eq. (13.6) and Eq. (13.7).

$$\eta = \frac{2 \cdot \alpha_U}{\sqrt{3} \cdot \gamma_m \cdot \gamma_{SC} \cdot \gamma_{inc}} \quad (13.5)$$

$$p_d \frac{D - t_1}{2 \cdot t_1} \leq \eta \cdot (SMYS - f_{y,temp}) \quad (13.6)$$

$$p_d \frac{D - t_1}{2 \cdot t_1} \leq \frac{\eta}{1.15} \cdot (SMYS - f_{u,temp}) \quad (13.7)$$

The corresponding usage factors for $\gamma_{inc} = 1.10$ are given in Table 13-3.

Utilisation factor, α_U	Safety Class			Pressure test
	Low	Medium	High	
1.00	0.847 ³⁾ (0.843)	0.802	0.698 ¹⁾	0.96
0.96	0.813 ³⁾ (0.838)	0.77	0.67 ²⁾	0.96

1) In location class 1, 0.802 may be used
 2) In location class 1, 0.77 may be used
 3) Effectively this factor since the pressure test is governing

D 500 Pressure containment criterion, design pressure less than 10% below the incidental pressure

The characteristic pressure when determining the wall thickness is the local incidental pressure. The submarine pipeline system shall have a Pipeline Control and Safety System which ensures that there is a probability for exceeding the local incidental pressure at any point in the system less than 10^{-2} within a year. If it can be documented that the ratio between incidental and design pressure, γ_{inc} , can be reduced, a corresponding reduction in wall thickness can be achieved, alternatively a higher design pressure can be used. For hydraulically “softer” systems like gas trunk lines, a γ_{inc} of 1.05 is often achieved.

D 600 HIPPS and similar systems

A pipeline is designed for a static pressure without allowing for the pressure loss along the pipe unless the pipeline is sectionised into parts with different design pressure. Hence, the pipeline will always have a pressure during normal operation lower than the design pressure due to the pressure drop caused by the flow of the fluid.

For high pressure wells, this downstream pressure may be reduced on purpose by a choke in order to enable a lower pressure pipeline downstream. This reduced pressure is dependent on a constant flow and will increase to the shut-in pressure in case of blockage downstream.

A High Integrity Pressure Protection System (HIPPS) serve the purpose to protect the downstream pipeline from the shut-in pressure by stopping the flow in case a pressure increase is experience (due to some blocking down-stream). The closer this blockage is to the HIPPS, the faster will the pressure increase occur. Hence, the speed of this HIPPS will determine how long part of the pipeline downstream that not can be protected but designed for the full shut-in pressure. This part is referred to as the fortified zone.

In case of failure of this HIPP system, the downstream pipeline will experience the full shut-in pressure. In order to take advantage of a HIPP system, the annual probability of this to happen must be less than 10^{-2} .

The resulting annual extreme pressure distribution will then be similar to Figure 1, a two peak distribution where the right peak describes the pressure distribution in case of failure of the HIPPS.

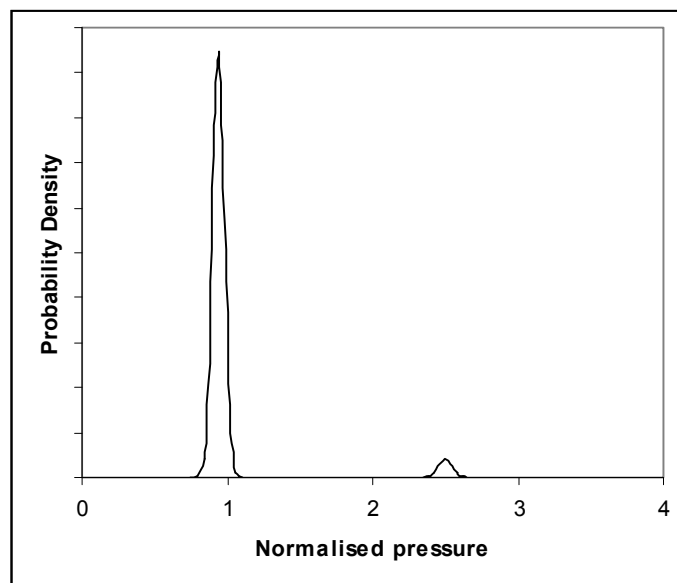

Figure 1

From the example in the figure, it is evident that the over pressure scenario will burst the pipeline (a factor 2.5 times the incidental pressure).

For a failure probability less than 10^{-2} this over-pressure may be considered as an accidental limit state and the methodology in Sec.5 D1000 may be used. The wall thickness will then be the larger of the pressure containment criterion based:

- on the choke pressure and
- the accidental scenario of the shut-in pressure.

With the example in Figure 1 the accidental scenario will govern the wall thickness design. If the over pressure would have been less than 20-30% above the incidental pressure, the choke pressure may govern the design.

The accidental criterion is:

$$\sum p_{f|Di} \cdot P_{Di} \leq p_{f,T} \quad (13.8)$$

where $p_{f|Di}$ is the failure probability given that the scenario happens and P_{Di} is the probability of the scenario (over pressure) to happen. In the following, it is assumed that the over pressure scenario will be the overall contributing accidental scenario and the summation sign is neglected.

For the HIPPS scenario outlined above, the probability of the scenario, P_{Di} , will be equal to the probability of a blockage to happen times the on-demand-failure of the HIPPS.

$$P_{Di} = P_{\text{blockage}} \cdot P_{\text{failure on demand(HIPPS)}} \quad (13.9)$$

The resulting wall thickness for the accidental scenario will then be the wall thickness giving the failure probability required in accordance with 13.8

Note that the nominal target failure probability in accordance with Sec.2 primarily shall be equal to similar limit states. The nominal failure probability of the pressure containment criterion is at least one order of magnitude less than the other limit states target values in Table 2-5.

D 700 Local buckling - collapse

The collapse pressure, p_c , is a function of the:

- elastic capacity
- plastic capacity
- the ovality.

The formulation adopted in this standard is identical as in BS8010, apart from the safety margin. The formula is given in Eq. (13.10) with the defined elastic and plastic capacities in Eq. (13.11) and Eq. (13.12).

$$(p_c(t) - p_{el}(t)) \cdot (p_c(t)^2 - p_p(t)^2) = p_c(t) \cdot p_{el}(t) \cdot p_p(t) \cdot f_o \cdot \frac{D}{t} \quad (13.10)$$

$$p_{el}(t) = \frac{2 \cdot E \cdot \left(\frac{t}{D}\right)^3}{1 - \nu^2} \quad (13.11)$$

$$p_p(t) = f_y \cdot \alpha_{fab} \cdot \frac{2 \cdot t}{D} \quad (13.12)$$

This third degree polynomial has the following analytical solution:

$$p_c = y - \frac{1}{3}b \quad (13.13)$$

where:

$$b = -p_{el}(t)$$

$$c = -(p_p(t)^2 + p_p(t)p_{el}(t)f_o \frac{D}{t})$$

$$d = p_{el}(t)p_p(t)^2$$

$$u = \frac{1}{3} \left(-\frac{1}{3}b^2 + c \right)$$

$$v = \frac{1}{2} \left(\frac{2}{27}b^3 - \frac{1}{3}bc + d \right)$$

$$\Phi = \cos^{-1} \left(\frac{-v}{\sqrt{-u^3}} \right)$$

$$y = -2\sqrt{-u} \cos \left(\frac{\Phi}{3} + \frac{60\pi}{180} \right)$$

D 800 Buckle arrestor

The buckle arrestor formula in Sec.5 is taken from Torselletti (2003).

D 900 Local buckling - moment

The given formula is valid for $15 < D/t_2 < 60$ for yielding and ovalisation failure modes. Up to D/t_2 equal to 45, these failure modes will occur prior to other failure modes, e.g. elastic buckling, and hence do not need to be checked.

Over D/t_2 45, elastic buckling has to be checked separately, typically through FE analysis, with D/t_2 a sufficient “safety margin” above the actual D/t_2 in order to account for both uncertainty as well as natural thickness variations.

In addition to check for elastic buckling, a thinner pipe becomes more susceptible to imperfections. Special considerations shall be made to

- girth welds and mismatch at girth welds, and
- point loads, e.g. point supports.

If both the elastic buckling has been documented to occur beyond the valid range and the implications of imperfections has found to be acceptable, the criteria may be extended to $D/t_2 = 60$.

D 1000 Local buckling - girth weld factor

Research on buckling of pipes including girth welds has shown that the girth weld has a significant impact on the compressive strain capacity, see Ghodsi (1994). A reduction in the order of 40% was found for $D/t_2 = 60$. There are no other known experiments on the impact from girth welds for lower D/t_2 .

It is assumed that the detrimental effect is due to on-set of buckling due to imperfections at the weld on the compressive side. If this is true, this effect will be more pronounced for higher D/t_2 's. The girth weld factor should be established by test and/or FE-calculations.

If no other information exists and given that the reduction is due to the misalignment on the compressive side, the reduction is expected to be negligible at $D/t_2 = 20$. A linear interpolation is then proposed up to $D/t_2 = 60$.

If no other information exists then the following girth weld factor is proposed.

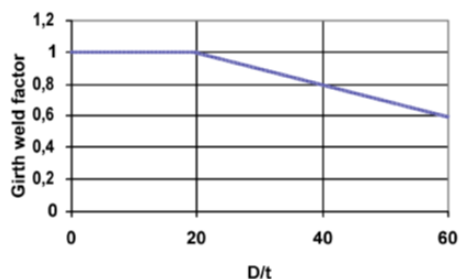

Figure 2
Proposed girth weld factors

D 1100 Ovalisation

Pipe ovalisation is mentioned in three different places within this standard:

Sec.5 D1100, where the maximum allowable ovalisation $f_0 = 3\%$. This applies for the pipeline as installed condition. This limitation is due to the given resistance formulations which not includes the ovality explicitly, as well as other functional aspects as stated in the paragraph.

Sec.5 D400, where the minimum ovalisation $f_0 = 0.5\%$ to be accounted for in the system collapse check; and the combined loading. The collapse formula includes the ovality explicitly giving a lower resistance for a larger ovality, hence a minimum ovality is prescribed.

Table 7-17, dimensional requirements, where the maximum allowable out of roundness to be delivered from Manufacturer is specified.

The ovality of a pipe exposed to bending strain may be estimated by Eq. (13.14). This is a characteristic formula

without any safety factors.

$$f_0' = \frac{f_0 + \left[0.030 \left(1 + \frac{D}{120t} \right) \left(2\varepsilon_c \frac{D}{t} \right)^2 \right]}{1 - \frac{P_e}{P_c}} \quad (13.14)$$

For further information, reference is made to Murphey (1985).

E. API Material Grades

E 100 API material grades

The API requirements to the Grades X42 through X80 are listed in Table 13-4. For full details see the API Specification for Line Pipe (API Specification 5L). The SMYS and SMTS values given in MPa in the table below are converted from the API specification (in ksi), and differ slightly from the mechanical properties in Sec.7 Table 7-5, which apply for this standard.

API Grade	SMYS		SMTS	
	ksi	MPa	ksi	MPa
X42	42	289	60	413
X46	46	317	63	434
X52	52	358	66	455
X56	56	386	71	489
X60	60	413	75	517
X65	65	448	77	530
X70	70	482	82	565
X80	80	551	90	620

ksi = 6.895 MPa; 1 MPa = 0.145 ksi; ksi = 1000 psi (lb f/in²)

F. Pipe-in-pipe and bundles

F 100 Pipe-in-pipe and bundles – general

This standard may generally be applied for pipe-in-pipe and bundles if the load effect calculations are performed adequately.

Structural parts of pipe-in-pipe system can be defined as inner pipe, outer pipe, intermittent layers and bulk heads.

The same safety class for inner pipe and outer pipe for pipe-in-pipe and bundles should be selected within the location class. In case it can be documented that a lower safety class for the inner pipe or outer pipe does not alter the net failure probability of the pipe-in-pipe, a lower safety class may be selected (safety class may hence be different for different failure modes).

When a pipe-in-pipe enters the platform area, typically a higher safety class is required, i.e. a wall thickness change in the inner pipe. If the outer pipe has a lower D/t, which is normally the case, this will rupture in case of leakage through the inner pipe. In case of a rather slow pressure build up in the annulus, the release is equally probable along the length, including the platform zone, adjusted for the length. Hence, entering the platform zone may require a thicker outer pipe. Alternatively, the inner pipe may be designed for the highest safety class along the full length, or fluid communication in the annulus between location class 1 and 2 is hindered.

Documentation of new pipe-in-pipe systems or bundles concepts should be carried out using technology qualification techniques (DNV-RP-A203).

The distance between the bulk heads are typically governed by the structural response and the associated uncertainties. Further, tie-ins and potential hot-taps should be considered. The design of the bulk heads should also assess consequence assessments related to damage of the bulk heads. Distance between water stops should be based upon consequence evaluations

F 200 Design load effects and design limit states

Load effect calculation requires knowledge about the actual layout of system, this is a main challenge compared a single pipe system. Load effect calculation may have additional uncertainties compared to single pipe

systems:

- Axial friction and sliding in between the inner and outer pipe (note that there is no buoyancy on inner pipe resulting in that even if the friction factor is lower compared to between outer pipe and soil, the friction force could be large)
- Bending interaction between inner and outer pipe, plasticity in the different pipes and load transfer shall be taken into account, ref. Goplen (2011)
- Temperature difference and different sources of heating
- Influence of spacers design, position and tolerances.

A pipe-in-pipe system that expands (as axial or lateral motions) will influence the axial loads in both inner- and outer pipe:

- Inner pipe in compression (equal or higher compared to single pipe)
- Outer pipe in tension (higher tension compared to single pipe).

Limit state criteria in Sec.5 are valid for each of the pipes. In case beneficial combined effect of inner pipe and outer pipe shall be considered, this shall be documented (e.g. collapse).

Compared to a single pipe solution the close to zero pressure in the annulus may imply higher wall thickness in the inner pipe caused by the pressure containment requirement (burst). Further, the bending capacity of the outer thinner pipe may be lower and hence influence on the total bending capacity of the pipe-in-pipe system.

Collapse is an issue throughout life time of the outer pipe as the pressure in the annulus often is close to zero and will be unchanged during lifetime.

The DNV-RP-F110 covering global buckling can be applied for a pipe-in-pipe in case the pipeline can be considered to have bonding in axial direction. Bonding is here related to no axial sliding between the inner and outer pipe. Hence a bonded pipe will have equal displacement pattern for both inner and outer pipe. An unbonded pipe-in-pipe will face larger uncertainties and higher degree of randomness in the imitation of global buckles and post buckling behavior. This must be reflected in the design approach and in the applied safety factors. The friction between the pipes is related to mechanical properties of spacers, insulation, rollers etc. that is used in the annulus. The friction is influenced by curvature in the pipe and the operational conditions of the pipe. The higher pressure and temperature, the higher friction is obtained.

Pipe-in-pipe has a high on-bottom stability level due to the high submerged weight, however, the potential for sinking into soil, particular fluidized sand or soft clay can be high and should be considered for both the installation and the operational phase.

Design of bulk heads will imply a code break, see Sec.5 F.

The acceptable dent size for the outer pipe shall be as for a single pipe, unless larger acceptable impacts can be documented. Different impact locations and consequences to be assessed (e.g. impact at spacer, bulk heads etc.).

Anode design will normally be equal to single pipe.

F 300 Construction – manufacture

For pipe-in-pipe and bundles the inner pipe and outer pipe shall have equal requirements to manufacture of linepipe, welding and connection. Temperature should be monitored in the individual pipes during construction. Tolerances related to distance keepers (spacers, foam etc) to be established and documented. Measure sliding between inner and outer pipe during construction of stalks

F 400 Construction – offshore

The effect of the installation by reeling on the various parts of the pipe-in-pipe system should be accounted for including straightening of inner and outer pipe during off-reeling, ref. Endal (1998). For installation by S-lay or J-lay sliding of the inner pipe shall be evaluated.

Leak testing of the annulus can be carried out to increase confidence in the construction and installation of the pipeline, e.g. pressure testing of the annulus.

During system pressure test there will be no external pressure on inner pipe, and this may affect the wall thickness sizing of the inner pipe.

F 500 Operation

Inspection possibilities are more limited for pipe-in-pipe and bundles, and hence detection of corrosion in annulus and external corrosion is challenging. Further, detection of leaks into annulus (from internal or external fluids) may not be easily identified and the associated environment in the annulus cannot be fully controlled or reversed. Documentation of the integrity in the operation phase may be limited for a pipe-in-pipe compared to a single pipe. This will again affect the life-time extension and re-assessment of the pipeline.

G. Installation

G 100 Safety class definition

Installation of pipeline and pipeline components is normally defined as safety class low. However, if the installation activity impose a higher risk to personnel, environment or the assets, a higher “safety class” should be used. Such activities may typically be repair, where the system is shut down, but the production medium is still within the system, modifications to existing system or installation operations where failure may lead to extensive economic loss, see also B100.

G 200 Coating

In case no other data is available the following criterion should be used. The mean overbend strain:

$$\varepsilon_{mean} = -\frac{D}{2R} + \varepsilon_{axial} \quad (13.15)$$

should satisfy:

$$\gamma_{cc} \varepsilon_{mean} \geq \varepsilon_{cc} \quad (13.16)$$

where

D = outer steel diameter

R = stinger radius

ε_{mean} = calculated mean overbend strain

ε_{axial} = axial strain contribution

γ_{cc} = 1.05 safety factor for concrete crushing

ε_{cc} = limit mean strain giving crushing of the concrete. Positive strain denotes tensile strain.

The mean overbend strain at which concrete crushing first occurs depends on the pipe stiffness, the concrete strength and thickness, the axial force and the shear resistance of the corrosion coating. Crushing occurs at lower mean overbend strains for lower concrete strength, lower axial force, higher pipe stiffness and higher shear resistance. If no other information is available, concrete crushing may be assumed to occur when the strain in the concrete (at the compressive fibre in the middle of the concrete thickness) reaches 0.2%.

For concrete coating of 40 mm thickness or more, together with asphalt corrosion coating, a conservative estimate of ε_{cc} is 0.22% for 42" pipelines and 0.24% for 16" pipelines, with linear interpolation in between.

Reference is made to Endal (1995) or Ness (1995).

G 300 Simplified laying criteria

This simplified laying criteria may be used as a preliminary simplified criterion of the local buckling check during early design stages. It does not supersede any of the failure mode checks as given in the normative part of the standard.

In addition to the simplified stress criteria given below, the limit states for concrete crushing (K200), Fatigue (Sec.5 D800) and Rotation (Sec.5 H200) shall be satisfied. Reference is further made to Endal et. al. (1995) for discussion on the Rotation limit state.

Overbend

For static loading the calculated strain shall satisfy Criterion I in Table 13-5. The strain shall include effects of bending, axial force and local roller loads. Effects due to varying stiffness (e.g. strain concentration at field joints or buckle arrestors) need not be included.

For static plus dynamic loading the calculated strain shall satisfy Criterion II in Table 13-5. The strain shall include all effects, including varying stiffness due to field joints or buckle arrestors.

Criterion	X70	X65	X60	X52
I	0.270%	0.250%	0.230%	0.205%
II	0.325%	0.305%	0.290%	0.260%

Sagbend

For combined static and dynamic loads the equivalent stress in the sagbend and at the stinger tip shall be less than

$$\sigma_{eq} < 0.87 \text{ times } f_y \quad (13.17)$$

with all load effect factors set to unity.

Effects due to varying stiffness or residual strain from the overbend may be ignored.

For the sagbend in deeper water, where collapse is a potential problem, the normative buckling criteria in the standard shall also be satisfied.

Calculation requirements

The following requirements to the lay analysis apply both when using Limit State Criteria and Simplified Criteria:

- The analysis shall be conducted using a realistic non-linear stress-strain (or moment-curvature) representation of the material (or cross-section).
- For calculation of strain concentration at field joints, non-linear material properties of the steel, the concrete and the corrosion coating shall be considered.
- The characteristic environmental load during installation is to be taken as the most probable largest value for the sea-state (H_s , T_p) considered with appropriate current and wind conditions. The sea-state duration considered is not to be less than 3 hrs.
- If the dynamic lay analysis is based on regular waves, it shall be documented that the choice of wave heights and periods conservatively represents the irregular sea-state (H_s , T_p).

H. References

- Endal G., Ness O. B., Verley R., Holthe K. and Ramseth S; “Behaviour of Offshore Pipelines Subjected to Residual Curvature During Laying”, Proceedings of OMAE'95 conference, Copenhagen, Denmark
- Endal, G., Williams, K.A., Kvello, O. and Hammer, G., “The Gullfaks Satellites Project: Reel Installation of 6"/10" Pipe-in-Pipe Flowline”, OMAE 1998 - 3903, Lisbon, Portugal, 1998.
- Ghodsi Nader Yoosef-, Kulak G. L. and Murray D. W.; “Behaviour of Girth Welded Line-pipe”, University of Alberta department of Civil Engineering, Structural Engineering Report No. 23, 1994
- Goplen S., Fyrileiv O., Grandal J. P., Børsheim L. “Global buckling of pipe-in-pipe - Structural response and design criteria”, OMAE 2011-49960, OMAE 2011, Rotterdam
- Jiao G., Sotberg T., Bruschi R., Verley R. and Mørk K; “The SUPERB Project: Wall Thickness Design Guideline for Pressure Containment of Offshore Pipelines”, Proceedings of OMAE'96 conference, Florence, Italy
- Murphey D.E. and Langner C. G. “Ultimate pipe strength under bending collapse and fatigue”, Offshore Mechanics and Arctic Engineering symposium, New Orleans 1985.
- Mørk. K, Spiten J., Torselletti E., Ness O. B., and Verley R.; “The SUPERB Project and DNV'96: Buckling and Collapse Limit State”, Proceedings of OMAE'97 conference, Yokohama, Japan
- Ness O. B. and Verley R.; “Strain Concentrations in Pipelines with Concrete Coating: An Analytical Model”, Proceedings of OMAE'95 conference, Copenhagen, Denmark
- Torseletti E., Bruschi R., Marchesani F., Vitali L. “Buckle Propagation and its Arrest: Buckle Arrestor Design Versus Numerical Analyses and Experiments” OMAE2003-37220
- Vitali L., Bruschi R., Mørk K., Verley R.(1999); “Hotpipe project - Capacity of pipes subjected to internal pressure, axial force and bending moment”, Proc. 9th Int. Offshore and Polar Engineering Conference, Brest 1999.

APPENDIX A

FRACTURE LIMIT STATE OF GIRTH WELDS

A. General

A 100 Introduction

101 The purpose of the fracture limit state evaluation of girth welds in pipelines is to avoid “failure” during the installation and operation stages by determining the criticality of flaws. The procedures described are based on fracture mechanics and the term “Engineering Critical Assessment” (ECA) is used. Unstable fracture, tearing and fatigue crack growth assessments are assessed under both static and dynamic (fatigue) loading as relevant.

The fracture mechanics approach specified does not explicitly refer to a defined safety level, but it is specified how the input to the analyses shall be defined in order to obtain acceptable fracture limit state.

102 Typically the assessments are used to:

- a) Derive defect acceptance criteria
- b) Perform fitness-for-purpose evaluations considering fracture limit state, e.g.:
 - to assess the effect of changed conditions (temperature, strain level, lifetime extension etc.)
 - to assess the significance of weld flaws or damage incurred after installation.

103 The ECA does not provide defect acceptance criteria for UT/AUT. The intention of an ECA is to provide critical “flaw” dimensions for given material properties and loading conditions in a conservative way. The derivation of “defect acceptance criteria” for UT/AUT shall be based on the critical flaw sizes obtained from the ECA and considering, probability of detection and defect sizing error in accordance with the recommendations and limitations of Appendix D and Appendix E.

104 The height of weld defects close to the internal or the external surface discovered during NDT shall be defined as the defect height itself plus the height of the remaining ligament if the ligament is less than half the height of the weld defect, see App.D Table D-6 and App.E B111.

105 The different failure modes considered in the assessment approach are:

- unstable fracture
- specified amount of tearing exceeded
- fatigue crack growth until unstable fracture or a defined crack size

106 For girth welds, it is the pipeline longitudinal stress-strain condition that is of relevance during installation. All strain requirements/limitations for girth welds are defined as the total nominal strain (elastic plus plastic), $\epsilon_{l,nom}$ in the pipe longitudinal direction. The total nominal strain shall be inclusive of global stiffness variations (e.g. coating discontinuities, wall thickness changes, etc.). However, any other local effects, such as wall thickness mismatch and joint misalignment effects, etc., shall be considered/analysed with the methodology presented herein. For assessments of the operational stage, the effect of hoop stresses also need to be considered, see B103, C103 and D205.

107 The fracture limit state is considered acceptable if the following is fulfilled:

- the maximum longitudinal strain, $\epsilon_{l,nom}$ is not larger than 0.4%
- the maximum size of weld defects is in accordance with Appendix D and Appendix E
- the material is in accordance with Sec.6 and 7
- the girth welds have acceptable fatigue capacity considering the relevant environment according to Sec.5 D800
- the environment is not such that it promotes hydrogen assisted cracking (sour service, HISC etc.)
- the assessment temperatures are not below -20°C and/or not above $+100^{\circ}\text{C}$

or

an ECA is performed as specified in this Appendix and acceptance criteria are determined in accordance with Appendix D and Appendix E as relevant.

108 The fatigue assessment procedure described in this Appendix (Subsection F) is supplementary to the fatigue design guidance described in the main body of this document (the S-N approach). Assessment of the fatigue life shall satisfy the requirement listed here and described in Sec.5 D800.

A 200 Objective

201 This Appendix provides detailed procedures for evaluation of the fracture limit state of girth welds considering weld flaws during installation and operation.

A 300 Application

301 In general, procedures for assessing girth welds under load- or strain-based conditions are described. The procedures are also applicable for assessing flaws in parent pipe. For pipelines large strains are mainly caused by global bending resulting mainly in membrane stress in the pipe wall.

302 This Appendix is not applicable to flexible pipes or dynamic or compliant risers.

303 The integrity of girth welds in lined and clad pipelines may be evaluated according to the procedures described in this appendix provided that the weld metal has at least even-match strength compared with the parent pipe material. However, the integrity of the CRA layer shall be considered in addition.

304 Some materials are sensitive to environmentally induced embrittlement, e.g. due to hydrogen from sour service or cathodic protection. In such cases the choice of toughness and fatigue properties shall reflect the actual environment. See also G106.

305 This Appendix is not applicable where the YS and/or UTS of the weld is under-matched with respect to the parent pipe material. In such cases specialist advice shall be sought.

A 400 Fracture toughness

401 The fracture toughness properties should be determined from a fracture toughness test programme using single edge notched tensile (SENT) specimens in accordance with Subsection G, Appendix B and DNV-RP-F108. However, other fracture toughness test methods and specimen geometries may be used provided that it can be demonstrated that these test techniques are conservative in relation to their application.

Guidance note:

The ECA procedures described in this Appendix requires that fracture toughness testing is performed. Hence, the pipe dimensions which may be assessed according to this Appendix depend on the limitations with respect to the fracture toughness testing. It is recommended that the dimensions of SENT specimens are not less than $W = 8$ mm and B shall be at least equal to W, see Figure 1. However, it is recommended that $B = 2W$ and the specimens shall be as large as possible, see DNV-RP-F108 for further details.

If fracture toughness testing is not possible and the $\epsilon_{l,nom}$ exceeds 0.4%, full scale testing or pipe segment testing shall be performed to prove the integrity of the girth welds including worst case weld defects. The testing shall reflect the worst case loading condition, relevant temperature, unfavourable material properties and unfavourable girth weld geometry.

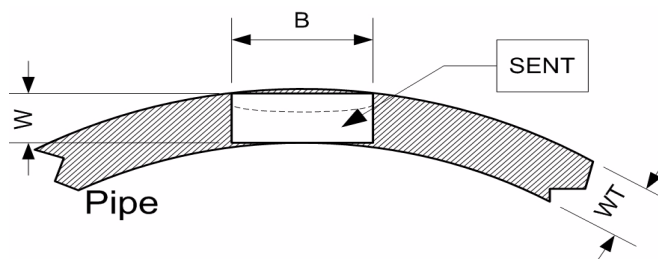

Figure 1
SENT geometry

---e-n-d---of---G-u-i-d-a-n-c-e---n-o-t-e---

402 The fracture toughness requirements specified in this Appendix is expressed in terms of the J value. However, the fracture toughness may be expressed in terms of the crack tip opening displacement (CTOD). If SENT specimens are tested the procedure for calculating CTOD fracture toughness shall be demonstrated to be conservative. G107 describes how the same ECA result is obtained both with fracture toughness specified as CTOD or J.

403 If the ECA is based on CTOD the conversion factor, X (see BS 7910), shall be defined as follows:

$CTOD_{mat} \leq 0.1$ mm;	$X = 1.8$
0.1 mm < $CTOD_{mat} < 0.4$ mm;	$X = 1.9 - CTOD_{mat}$
$CTOD_{mat} \geq 0.4$ mm;	$X = 1.5$

404 It is possible to estimate K_{IC} from Charpy V-notch test results using correlation formulas. The results are however considered to be less reliable and it is not acceptable to assess the integrity of pipeline girth welds in accordance with this Appendix based on Charpy V-notch testing only. Such assessments are only considered as indications.

A 500 References

501 The following codes are referred to in this appendix:

API 579-1/ASME FFS-1	“Fitness-For-Service”, June 5 2007, Errata January 2009
ASTM E1820 – 11	“Standard Test Method for Measurement of Fracture Toughness”, August 2011
BS EN ISO 12737:2010	“Metallic materials – Determination of plane-strain fracture toughness”, December 2010
BS EN ISO 15653:2010	“Metallic materials – Method for the determination of quasistatic fracture toughness of welds”, April 2010
BS 7448-1:1991	“Fracture mechanics toughness tests. Method for determination of K_{Ic} , critical CTOD and critical J values of metallic materials”, 20 December 1991 (The standard is partially replaced by BS EN ISO 12737:1999)
BS 7448-2:1997	“Fracture mechanics toughness tests. Method for determination of K_{Ic} , critical CTOD and critical J values of welds in metallic materials”, 15 August 1997 (The standard was withdrawn 31 July 2010, replaced by BS EN ISO 15653:2010)
BS 7448-4:1997	“Fracture mechanics toughness tests. Method for determination of fracture resistance curves and initiation values for stable crack extension in metallic materials”, 15 December 1997
BS 7910:2005	“Guide to methods for assessing the acceptability of flaws in metallic structures”
DNV-RP-C203	“Fatigue Design of Offshore Steel Structures”, October 2011
DNV-RP-F108	“Fracture Control for Pipeline Installation Methods Introducing Cyclic Plastic Strain”, January 2006
R6	“Assessment of the Integrity of Structures containing Defects”, Version 4

B. Assessment Categories

B 100 General

101 Pipeline systems shall have adequate resistance against failure during the whole of its design life. This shall be achieved by selecting materials and welds with adequate fracture toughness, tensile properties and weld defect acceptance criteria.

102 The various assessment procedures provided in this Appendix are based on BS 7910. Hence the recommendations and requirements are only applicable if BS 7910 is the basis for the assessment with amendments and adjustments as described in this Appendix.

It is acceptable to base the integrity of welds on finite element (FE) analyses, see Subsection E, or other suitable standards such as API 579 and R6, but in such cases the assessment procedure shall be thoroughly described, documented and accepted by all parties.

103 The ECA procedures described in this standard generally consider uni-axial loading conditions. However, the operation of pipelines involves both internal pressure and axial strain, i.e. a bi-axial stress-strain state. ECA of the operational stage under biaxial stresses is described in D205 (last part).

Guidance note:

Full-scale testing and FE fracture mechanics analyses show that the fracture capacity for circumferentially aligned defects (such as those at girth welds) subject to an applied longitudinal strain is reduced if the pipeline is pressurized. This phenomenon is mainly caused by increased crack driving force. Assessment procedures considering internal overpressure combined with longitudinal tensile strains are under development, but are not implemented in this standard. Analysis for such situations must be well documented and based on well proven engineering principles e.g. 3D FE fracture mechanics analysis and accepted by all parties.

---e-n-d---of---G-u-i-d-a-n-c-e---n-o-t-e---

104 The assessment temperature is defined as the temperature representative for the stress-strain condition considered. It may be ambient (typically installation), elevated (e.g. lateral buckling) or sub-zero (e.g. shut-down). All testing should be performed at the assessment temperature, see Subsection G and 110.

If other test temperatures are chosen it must be substantiated that the testing gives conservative results as compared to testing at the assessment temperature.

105 Depending on the level of monotonic and cyclic deformations, the assessment procedure and required testing is divided in categories as follows:

- Maximum longitudinal strain, $\epsilon_{l,nom}$, equal to or larger than 0.4%, suffix *ECA static*. ECA static, may further be “generic” (see Subsection C) or “full” (see Subsection D).
- More than 10 nominal longitudinal stress ranges, $\Delta\sigma_{l,nom}$ larger than 200 MPa or more than 10 000 stress cycles with $\Delta\sigma_{l,nom}$ larger than 20 MPa suffix *ECA fatigue*, see Subsection F.

If the maximum longitudinal strain, $\varepsilon_{1,nom}$, is less than 0.4, it is acceptable to perform ECA as basis for increasing the UT or AUT acceptance criteria specified in App.D Table D-6 or App.E Table E-1. However, the general recommendation is not to use ECA to allow for reduced weld quality.

106 A pipeline may either be defined according to “ECA static”, “ECA fatigue” or as a combination of “static” and “fatigue”. All phases during manufacturing, fabrication, installation and operation shall be evaluated and included in the assessment of maximum allowable flaw sizes. If the size of weld defects indicates potential failures during installation or operation based on ECA, the allowable weld defect sizes shall be reduced. A typical ECA process is illustrated in Figure 2.

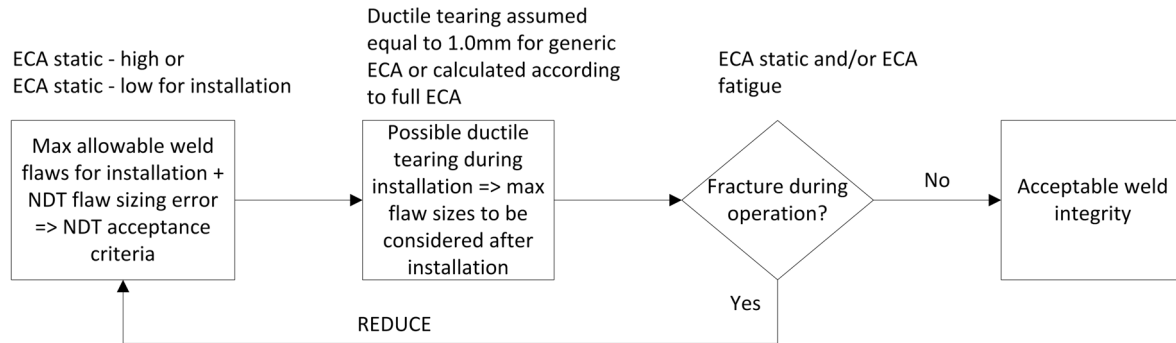

Figure 2
Illustration of a typical ECA process

107 When considering different load cases during installation and operation, e.g. installation by reeling plus installation fatigue plus free spanning fatigue plus lateral buckling, it is acceptable to evaluate if the different load cases represent system effect or not (are all welds subjected to all load cases?). If the probability that the same weld is subjected to more than one load case, in addition to installation loading, is evaluated to be less than 10^{-3} it is not required to combine those load cases and to add the crack extension from each of them. As an example, if it is evaluated that less than 1 weld out of 1000 will be subjected to both installation fatigue and free spanning fatigue it is not required to add the crack extension for both these events. However, each weld must be able to withstand installation loading plus each of the separate subsequent load cases but it is only required to add the crack extension from the additional load cases that are evaluated to occur at that weld with a probability larger than 10^{-3} , see also F104.

If the accumulated S-N Miner sum multiplied by the DFF is less than 0.01 in accordance with Sec.5 D800, the load case does not need to be included in the ECA.

108 It shall be evaluated if the loading mode in consideration is displacement controlled or load controlled and the assessment methodology shall reflect this. Offshore submarine pipelines are mainly displacement controlled during installation (e.g. bending controlled by curvature.) and it is acceptable to follow the displacement controlled (strain-based) procedure which is presented in this standard.

Where the pipeline is load-controlled (e.g. some operational conditions or whilst in the lay catenary) the special considerations specified in 109 apply.

109 If the loading mode is load controlled and it is natural to specify the applied load as a tension stress, the assessment methodology specified in this Appendix can be used with the following changes:

- if pre-straining is relevant (see Subsection G), the final strain cycle applied to the test specimen blanks shall end in compression. Tensile test results and fracture toughness results from this material shall be used in the assessment
- if pre-straining is not relevant the stress-strain curve used in the assessments shall either represent SMYS/SMTS properties or a “lower-bound” stress-strain curve shall be established from testing
- $L_{r,max}$ (L_r cut-off), see D208, shall be defined as:

$$L_{r,max} = \frac{YS + UTS}{2 \cdot YS} \quad \text{Eq. A.1}$$

where UTS is the engineering tensile strength and YS is the engineering yield stress of the parent pipe.

A lower-bound stress-strain curve shall either be described:

- based on SMYS defined as $R_{10.5}$ and SMTS with justified uniform elongation
- based on tensile test results where the YS and UTS is determined as mean values minus X from Table A-1 multiplied with the standard deviation. The tensile properties determined according to Table A-1 correspond to the 2.3% probability with a mean value estimated with at least 95% confidence

— the stress-strain curve shall include a yield discontinuity (Lüder plateau) as relevant

Table A-1 Number of standard deviations X to be subtracted from the mean YS and UTS to derive lower-bound stress-strain properties	
<i>Number of tests, n</i>	<i>X</i>
3	9.24
5	5.01
10	3.45
15	3.07
20	2.88
30	2.65
50	2.48
100	2.32
∞	2.00

For strain-based loading see D204.

110 The effect of plastic deformation, possible ageing and the assessment temperature shall be taken into account when fracture toughness testing and tensile testing is performed, see Subsection G.

C. Generic ECA for Girth Welds subjected to Strains Less than 2.25% Assessed According to ECA Static

C 100 General

101 The maximum allowable flaws specified in Table A-3 to A-6, suitably adjusted to account for sizing accuracy, may be used for the final weld defect acceptance criteria. This is only acceptable if all requirements specified in A100, A300 and 103 are fulfilled.

102 The generic ECA is based on Level 3B (fracture resistance curve needed) according to BS 7910 with amendments and adjustments as described in this Appendix. The crack growth including blunting (total a_0 minus a_0) shall be measured for all the SENT tests. For each set (3 specimens) one test shall be tested beyond maximum load (notch opening displacement (V) at maximum load multiplied by 1.1), one test shall be tested to maximum load and one test shall be unloaded before maximum load.

103 This generic ECA is not applicable for the following situations:

- clad or lined pipelines (special advice must be sought)
- pipelines subjected to a combination of internal overpressure and $\epsilon_{1,nom} > 0.4\%$, see D205 (last part)
- where the girth welds have under-matching strength compared to the parent pipe, see D110
- if more than 5 tensile strain cycles are applied (e.g. one contingency operation during reeling installation is acceptable)
- if the girth welds are not tested in accordance with Table A-2, Subsection G and Appendix B
- if the linepipes have not been tested and designed according to Sec.6 and Sec.7
- if the difference in yield stress between adjacent linepipes exceeds 100 MPa
- if the stress-strain curve exhibit a Lüder plateau (yield discontinuity in the stress-strain curve) and the maximum length of the plateau seen during production tensile testing and tensile testing according to Table A-2 exceeds 2%
- if experimentally determined values of J do not meet the requirements specified in Table A-3 to Table A-6 (see Figure 4)
- if significant pop-ins (see e.g. BS 7448: Part 1 and 4, ASTM E1820 or ISO 15653) or unstable fracture occur prior to maximum load during fracture toughness testing
- if geometry, applied strain, fracture toughness and maximum misalignment are not within the limitations specified in Table A-3 to Table A-6
- if the following YS/UTS ratios are not met during the production qualification tests or the parent pipe tensile testing specified in Table A-2:
 - YS/UTS ≤ 0.90 for C-Mn with SMYS ≤ 555 MPa
 - YS/UTS ≤ 0.85 for 13Cr

104 If any of the requirements specified in 103 are not met, a full ECA shall be performed according to Subsection D.

105 Where the pipeline is subjected to fatigue during operation or installation the maximum allowable flaw sizes determined from Tables A-3 to A-6 shall be adjusted to account for possible fatigue crack growth in accordance with Subsection F.

106 If ECA is performed for the operational phase based on generic ECA for the installation phase, the crack height shall be increased by 0.5 mm for the subsequent operational ECA if $0.4\% < \epsilon_{1, \text{nom}} \leq 1.0\%$ during installation. If $\epsilon_{1, \text{nom}}$ exceeded 1% during installation the crack height shall be increased by 1.0 mm for the subsequent operational ECA in order to account for tearing.

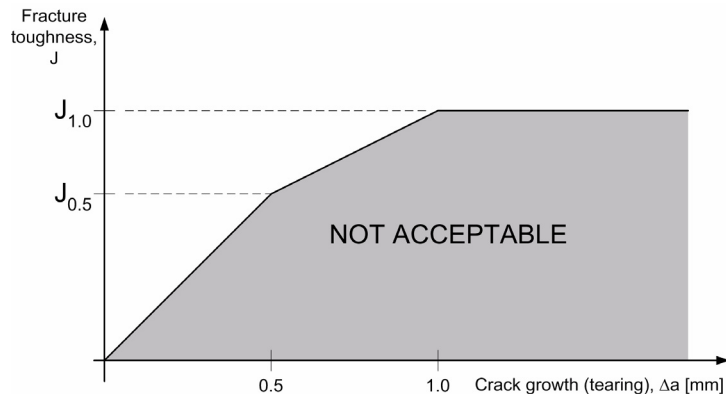

Figure 3
 No J Δa test results shall end-up inside the area indicated

Type of test	Location	Test quantity
Weld metal tensile testing ^{4), 5)}	Transverse girth weld	3
Parent pipe tensile testing ^{4), 5)}	Parent pipe, longitudinal	5
J R testing of SENT specimens ^{5), 6)}	Main line	3 specimens for each notch position, see Appendix B
J R testing of SENT specimens ^{5), 6)}	Double joint	3 specimens for each notch position, see Appendix B
J R testing of SENT specimens ^{5), 6)}	Through thickness repair (TTR)	3 specimens for each notch position, see Appendix B
J R testing of SENT specimens ^{5), 6)}	Partial repair ³⁾	3 specimens for each notch position, see Appendix B

1) All weld procedures which have different essential variables according to Appendix C, Table C-2 shall be tested
 2) The test temperatures and material condition to be tested shall be as specified in Subsection G
 3) If the welding procedure and heat input is equal to the through thickness repair procedure, this testing may be omitted. If repeated repairs are permitted or agreed relevant microstructures must be tested
 4) The test results shall be from at least two different pipes (different pipe numbers/two different girth welds). If production tensile testing is performed at the assessment temperature and full stress-strain curves are established, additional tensile testing is not required
 5) The specimen geometry and test requirements are specified in Appendix B
 6) The blunting shall be included in the tearing length

J [N/mm = kJ/m ²]	Nominal outer diameter, $8'' \leq D \leq 12''$, WT = nominal wall thickness							
	C-Mn; SMYS ≤ 450		C-Mn; SMYS = 485		C-Mn; SMYS = 555		13Cr; SMYS = 550	
	$15 \leq WT < 25$	$WT \geq 25$	$15 \leq WT < 25$	$WT \geq 25$	$15 \leq WT < 25$	$WT \geq 25$	$15 \leq WT < 25$	$WT \geq 25$
$J_{0.5} = 400$ and $J_{1.0} = 600$	3×25 4×20 5×15	3×55 4×25 5×20	3×25 4×15 5×15	3×40 4×25 5×20	3×20 4×15 5×10	3×30 4×20 5×15	3×30 4×20 5×15	3×60 4×35 4×25
$J_{0.5} = 600$ and $J_{1.0} = 800$	3×50 4×30 5×20	3×100 4×50 5×35	3×45 4×25 5×20	3×90 4×45 5×30	3×35 4×20 5×15	3×80 4×40 5×25	3×45 4×25 5×20	3×95 4×55 5×40
$J_{0.5} = 800$ and $J_{1.0} = 1000$	3×70 4×40 5×25	3×150 4×80 5×50	3×65 4×35 5×25	3×145 4×70 5×45	3×55 4×30 5×20	3×115 4×60 5×40	3×50 4×30 5×25	3×100 4×70 5×50
δ_{max} [mm], see D205	1.8	2.5	1.8	2.5	1.8	2.5	1.8	2.5

1) Larger allowable flaw sizes may be acceptable based on full ECA
 2) Only acceptable if testing as specified in Table A-2 has been performed
 3) Maximum allowable flaw size, $a \times 2c$ refers to height and length respectively of both surface breaking and embedded flaws. If the embedded flaw is located close to the surface (ligament height less than half the flaw height) the ligament height between the flaw and the surface shall be included in the flaw height. The UT/AUT flaw sizing error must be subtracted from the maximum allowable flaw height to establish the UT/AUT weld defect acceptance criteria, see Appendix D and Appendix E

Table A-4 Maximum allowable flaw sizes, $a \times 2c$ [mm], maximum strain, $0.4\% \leq \epsilon_{l,nom} < 1\%$ 1), 2), 3)

J [N/mm = kJ/m ²]	Nominal outer diameter, $12'' < D \leq 16''$, WT = nominal wall thickness							
	C-Mn; SMYS ≤ 450		C-Mn; SMYS = 485		C-Mn; SMYS = 555		13Cr; SMYS = 550	
	$15 \leq WT < 25$	$WT \geq 25$	$15 \leq WT < 25$	$WT \geq 25$	$15 \leq WT < 25$	$WT \geq 25$	$15 \leq WT < 25$	$WT \geq 25$
$J_{0.5} = 400$ and $J_{1.0} = 600$	3×35 4×20 5×15	3×75 4×30 5×25	3×30 4×20 5×15	3×55 4×30 5×20	3×25 4×15 5×15	3×40 4×25 5×20	3×40 4×25 5×20	3×90 4×45 5×30
$J_{0.5} = 600$ and $J_{1.0} = 800$	3×65 4×35 5×25	3×150 4×75 5×45	3×60 4×30 5×20	3×135 4×65 5×40	3×50 4×25 5×20	3×115 4×50 5×30	3×65 4×35 5×25	3×145 4×80 5×50
$J_{0.5} = 800$ and $J_{1.0} = 1000$	3×95 4×50 5×35	3×150 4×115 5×70	3×85 4×45 5×30	3×150 4×100 5×60	3×80 4×40 5×25	3×150 4×85 5×50	3×75 4×45 5×30	3×150 4×105 5×70
δ_{max} [mm], see D205	1.8	2.5	1.8	2.5	1.8	2.5	1.8	2.5

- 1) Larger allowable flaw sizes may be acceptable based on full ECA
- 2) Only acceptable if testing as specified in Table A-2 has been performed
- 3) Maximum allowable flaw size, $a \times 2c$ refers to height and length respectively of both surface breaking and embedded flaws. If the embedded flaw is located close to the surface (ligament height less than half the flaw height) the ligament height between the flaw and the surface shall be included in the flaw height. The UT/AUT flaw sizing error must be subtracted from the maximum allowable flaw height to establish the UT/AUT weld defect acceptance criteria, see Appendix D and Appendix E

Table A-5 Maximum allowable flaw sizes, $a \times 2c$ [mm], maximum strain, $0.4\% \leq \epsilon_{l,nom} < 1\%$ 1), 2), 3)

J [N/mm = kJ/m ²]	Nominal outer diameter, $D > 16''$, WT = nominal wall thickness							
	C-Mn; SMYS ≤ 450		C-Mn; SMYS = 485		C-Mn; SMYS = 555		13Cr; SMYS = 550	
	$15 \leq WT < 25$	$WT \geq 25$	$15 \leq WT < 25$	$WT \geq 25$	$15 \leq WT < 25$	$WT \geq 25$	$15 \leq WT < 25$	$WT \geq 25$
$J_{0.5} = 400$ and $J_{1.0} = 600$	3×40 4×20 5×15	3×90 4×35 5×25	3×30 4×20 5×15	3×70 4×35 5×25	3×25 4×15 5×15	3×50 4×30 5×25	3×50 4×30 5×20	3×125 4×60 5×40
$J_{0.5} = 600$ and $J_{1.0} = 800$	3×80 4×40 5×25	3×150 4×90 5×50	3×70 4×35 5×25	3×150 4×75 5×45	3×60 4×30 5×20	3×140 4×60 5×35	3×85 4×45 5×20	3×150 4×105 5×65
$J_{0.5} = 800$ and $J_{1.0} = 1000$	3×120 4×60 5×35	3×150 4×145 5×80	3×105 4×50 5×35	3×150 4×125 5×70	3×95 4×45 5×30	3×150 4×105 5×60	3×100 4×60 5×40	3×150 4×145 5×90
δ_{max} [mm], see D205	1.5	2.0	1.5	2.0	1.5	2.0	1.5	2.0

- 1) Larger allowable flaw sizes may be acceptable based on full ECA
- 2) Only acceptable if testing as specified in Table A-2 has been performed
- 3) Maximum allowable flaw size, $a \times 2c$ refers to height and length respectively of both surface breaking and embedded flaws. If the embedded flaw is located close to the surface (ligament height less than half the flaw height) the ligament height between the flaw and the surface shall be included in the flaw height. The UT/AUT flaw sizing error must be subtracted from the maximum allowable flaw height to establish the UT/AUT weld defect acceptance criteria, see Appendix D and Appendix E

Table A-6 Maximum allowable flaw sizes, $a \times 2c$ [mm], maximum strain, $1.0\% < \epsilon_{i,nom} < 2.25\%$ 1), 2), 3)

J [N/mm = kJ/m ²]	Nominal outer diameter, $8'' \leq D \leq 16''$, $WT =$ nominal wall thickness							
	C-Mn; SMYS ≤ 450		C-Mn; SMYS = 485		C-Mn; SMYS = 555		13Cr; SMYS = 550	
	$15 \leq WT < 25$	$WT \geq 25$	$15 \leq WT < 25$	$WT \geq 25$	$15 \leq WT < 25$	$WT \geq 25$	$15 \leq WT < 25$	$WT \geq 25$
$J_{0.5} = 400$ and $J_{1.0} = 600$	3×20 4×15 5×10	3×35 4×20 5×15	3×20 4×15 5×10	3×30 4×20 5×15	3×15 4×10	3×25 4×15 4×10	3×15 4×10 5×10	3×25 4×20 5×15
$J_{0.5} = 600$ and $J_{1.0} = 800$	3×35 4×20 5×15	3×85 4×40 5×30	3×35 4×20 5×15	3×75 4×35 5×25	3×30 4×20 5×15	3×60 4×30 5×20	3×30 4×20 5×15	3×60 4×30 5×25
$J_{0.5} = 800$ and $J_{1.0} = 1000$	3×45 4×30 5×20	3×95 4×65 5×40	3×45 4×30 5×20	3×95 4×60 5×40	3×45 4×25 5×20	3×95 4×50 5×30	3×35 4×25 5×15	3×75 4×50 5×30
δ_{max} [mm], see D205	1.5	2.0	1.5	2.0	1.5	2.0	1.5	2.0

1) Larger allowable flaw sizes may be acceptable based on full ECA
 2) Only acceptable if testing as specified in Table A-2 has been performed
 3) Maximum allowable flaw size, $a \times 2c$ refers to height and length respectively of both surface breaking and embedded flaws. If the embedded flaw is located close to the surface (ligament height less than half the flaw height) the ligament height between the flaw and the surface shall be included in the flaw height. The UT/AUT flaw sizing error must be subtracted from the maximum allowable flaw height to establish the UT/AUT weld defect acceptance criteria, see Appendix D and Appendix E

D. Girth Welds under Strain-based Loading Assessed According to ECA Static - Full

D 100 General

101 The assessment procedure specified in this subsection has been used successfully for many years. It is known that the “*crack driving force*” (CDF) for girth welds without misalignments and weld residual stresses is inaccurately assessed in some cases. However, the weld metal has typically over-matching strength compared with the parent pipe material and this is not accounted for in the assessments. Furthermore, the definition of weld residual stresses are believed to be conservative and based on general industry experience the whole assessment methodology has proven to be conservative.

It is not acceptable to relax the definition of weld residual stresses to lower than specified in this Appendix or to make other inputs less significant than specified in this Section without further evidence. Assessment approaches not in accordance with this Appendix shall be compared with CDF derived with dedicated FE analyses, see Subsection E.

If other procedures than specified in this Subsection are used to derive weld defect acceptance criteria the results will in general not satisfy this Standard and it must be up to the end user to accept the final weld defect acceptance criteria derived.

102 The recommended procedure is to assess maximum allowable external surface flaws, internal surface flaws and embedded flaws with ligament height 3mm. However, it is acceptable to only assess surface breaking flaws and to regard the maximum allowable flaw heights assessed as valid also for embedded flaws with the same length.

Table A-7 specifies how the critical flaw size shall be assessed according to this procedure.

Table A-7 Assessment of critical flaw sizes

Type of flaw	Stress intensity factor solution	Reference stress solution	Fracture toughness	Weld residual stress, Q_m	M_k BS7910
External surface flaw	BS 7910 M.3.2, plate solution	BS 7910, plate solution, P.3.2 (P.2)	SENT testing in environment representative for the external surface	Equal to YS of parent pipe, uniform through thickness. Relaxation allowed for	Not required
Internal surface flaw	BS 7910 M.3.2, plate solution	BS 7910, plate solution, P.3.2 (P.2)	SENT testing in environment representative for the internal surface		
Embedded flaw with ligament height 3mm	BS 7910 M.3.4, plate solution	BS 7910, plate solution, P.3.4	SENT testing in environment representative for embedded flaws		

The applied primary stresses shall be defined in accordance with 205.

103 For load-controlled conditions, this procedure may be followed provided B109 is followed.

104 If the generic ECA is not applicable or if the maximum allowable flaw sizes assessed by ECA generic

are not as required/desirable a full ECA shall be performed which may improve the results.

105 The ECA provides allowable flaw heights without UT/AUT flaw sizing error. For determination of weld defect acceptance criteria, see Appendix D and Appendix E.

106 The linepipes shall be tested and designed according to Sec.6 and Sec.7 and the girth welds shall be tested according to Table A-8, Subsection G and Appendix B.

107 The ECA static – full procedure is only acceptable if limitations specified in A100 and A300 applies.

108 Full ECA requires more testing than the generic ECA, see Table A-2 and Table A-8. Tests already performed for a generic ECA may be used when constructing the J R-curves required for the full ECA.

109 The crack growth including blunting (total a minus a_0) shall be measured for all the SENT tests. A minimum of 6 SENT specimens should be used to construct a J R-curve for each weld procedure considered. It is suggested that one specimen is tested beyond maximum load (notch opening displacement (V) at maximum load, multiplied by at least 1.1 (this is particular important for thinner test specimens)), that two specimens are tested to around maximum load and that the remaining 3 specimens are unloaded prior to maximum load at different V values. It is desirable to have one test with less than 0.3mm crack extension.

<i>Type of test</i>	<i>Location</i>	<i>Test quantity</i>
Weld metal tensile testing ^{4), 5)}	Girth weld	3
Parent pipe tensile testing ^{4), 5)}	Parent pipe, longitudinal	5
J-R testing of SENT specimens ^{5), 6)}	Main line	One J R-curve (minimum 6 SENT) for each notch position, see Appendix B
J-R testing of SENT specimens ^{5), 6)}	Double joint	One J R-curve (minimum 6 SENT) for each notch position, see Appendix B
J-R testing of SENT specimens ^{5), 6)}	Through thickness repair (TTR)	One J R-curve (minimum 6 SENT) for each notch position, see Appendix B
J-R testing of SENT specimens ^{5), 6)}	Partial repair ³⁾	One J R-curve (minimum 6 SENT) for each notch position, see Appendix B

1) All weld procedures which have different essential variables according to Appendix C, Table C-2 shall be tested
 2) The test temperatures and material condition to be tested shall be as specified in Subsection G
 3) If the welding procedure and heat input is equal to the through thickness repair procedure, this testing may be omitted. If repeated repairs are permitted or agreed relevant microstructures must be tested
 4) The test results shall be from at least two different pipes (different pipe numbers/two different girth welds). If production tensile testing is performed at the assessment temperature and full stress-strain curves are established, additional tensile testing is not required
 5) The specimen geometry and test requirements are specified in Appendix B
 6) The blunting shall be included in the tearing length

110 The parent pipe tensile properties and the weld metal tensile properties shall be assumed to be even-matching in the assessment, i.e. the stress-strain curve of the parent pipe material shall be used in the assessments. Because of the assumption of even-matching, it is assumed that the primary stresses are equal for defects located at the Fusion Line (FL) border and for defects located within the weld metal.

If weld metal strength overmatch is not obtained for all material conditions, the procedure for determination of applied stresses specified in D205 is not acceptable and special advice must be sought. Girth welds with less thickness than the parent pipe wall thickness is not acceptable (counter-boring is not acceptable).

A strength overmatching weld is obtained if the tensile stress-strain curves for the weld metal are higher than the tensile stress-strain curve of the parent pipe for all material conditions. This is considered fulfilled if the results from tensile testing show the following:

- All YS and UTS values of the weld metal is at least as high as the highest YS and UTS values for the parent pipe material respectively
- The mean value of YS and UTS for the weld metal is higher than the mean value of YS and UTS for the parent pipe respectively plus the standard deviation multiplied with the factor X from Table A-9

111 Weld residual stresses shall in general be assumed to be uniform and equal to the yield stress of the parent pipe and relaxation according to BS 7910 is acceptable. If the weld residual stress distribution is documented by sufficient simulations, it is acceptable to define the stress distribution more accurately, but then the normal relaxation according to BS 7910 is not acceptable.

112 Where the pipeline is subjected to fatigue loading during installation and/or operation the maximum allowable flaw sizes determined from the ECA shall be adjusted to account for possible fatigue crack growth if required according to B107 and Subsection F. Fatigue crack growth analyses shall be performed in accordance with Subsection F.

D 200 Assessment methodology

201 Strain based assessments with $\epsilon_{1,nom}$ exceeding 0.4% during installation shall be carried out in accordance with BS 7910 at assessment Level 3B with amendments and adjustments as described in this Appendix. If $\epsilon_{1,nom}$ is less than 0.4% it is acceptable to carry out a Level 2B assessment in accordance with BS 7910 with amendments and adjustments as described in this Appendix. Both assessments based on the Level 2B and 3B procedures require that material specific stress-strain curves are established. Fracture resistance curves (J R- or CTOD R-curve) is further required for assessments according to Level 3B while single parameter fracture toughness is required for Level 2B (CTOD or J).

It is recommended that the fracture resistance curves are presented as J R-curves established from SENT testing according to DNV-RP-F108, and Appendix B (see also Subsection G for further details). This is to ensure that a possible weld defect will not lead to fracture due to ductile tearing. Further, an assessment at Level 3B for the installation phase provides information about the defect size after installation which is needed for assessing possible fatigue crack growth and fracture during operation.

For the operational phase considering a combination of internal overpressure and longitudinal loading see last part of 205.

202 If an ECA is performed, the following requirements and recommendations are applicable:

- The nominal wall thickness minus the manufacturing tolerance of the pipe shall be used in assessments considering installation.
- A suitable corrosion allowance shall be included in the assessments during the operational life of the pipeline. At the end of design life the whole corrosion allowance shall be subtracted.
 In case of fitness-for-purpose evaluations it is acceptable to base the thickness on inspected values.
- The assessments shall be thoroughly defined and presented such that the assessment results are reproducible by a 3rd party.
- The sensitivity of different input parameters and the conservatism of the results should be evaluated and discussed.

203 Required inputs for an assessment according to ECA Static – Full, are:

- pipe dimensions, weld dimensions and dimensional tolerances
- tensile properties in the form of complete engineering stress-strain curves for the parent pipe material and evidence that the weld metal stress-strain curve over-matches the parent pipe stress-strain curve, see D110
- fracture toughness data for specimens with notches located both within the weld metal and at or near the fusion boundary as specified in this Appendix and Appendix B
- the L_r cut-off value (see D208)
- maximum acceptable tearing (stable crack extension/growth) (see D209)
- applied strain history during the installation phase and secondary stresses (e.g. residual stresses from the welding or installation processes)
- applied maximum longitudinal design stress/strain applicable to the operational life
- cyclic stress history applicable to the pipeline whilst it is in the lay catenary configuration and during the operational life.

204 Tensile properties and stress-strain curve for strain-based assessments shall be determined as follows:

- tensile testing performed during production or qualification shall be issued to the ECA contractor and the results shall be considered when the material specific stress-strain curve is constructed
- Stress-strain curves up to the uniform elongation (strain at UTS) should be reported from the tensile testing
- the tensile properties used in the ECA shall describe an upper-bound stress-strain curve with low strain hardening. The upper-bound stress-strain curve shall be constructed based on tensile test results from the relevant material condition as follows:
 - “Upper-bound” characteristic yield stress (YS) defined as the mean yield stress established from testing plus the factor X from Table A-9 times the standard deviation
 - Tensile strength (UTS) defined as the minimum UTS/YS ratio established from the testing multiplied with the “upper-bound” YS
 - The stress-strain curve shall have a Lüder plateau as relevant and the strain at UTS (uniform elongation) shall not be lower than the mean uniform elongation value established from the testing

Table A-10 Number of standard deviations X to be added to mean YS to derive upper-bound stress-strain properties

<i>Number of tests, n</i>	<i>X</i>
3	5.01
5	2.82
10	1.93
15	1.69

Table A-10 Number of standard deviations X to be added to mean YS to derive upper-bound stress-strain properties (Continued)

Number of tests, n	X
20	1.57
30	1.44
50	1.32
100	1.22
∞	1.00

Table A-10 gives the characteristic upper-bound yield stress defined as the 84.1% fractile (mean value plus one standard deviation) with 95% confidence in case the standard deviation is unknown in relation to the number of tests performed.

If parametric formulas are used the resulting stress-strain curve shall fit the shape of the experimental results reasonably well

- true uni-axial stress-strain curves shall be used as basis for the failure assessment curve. Engineering stress-strain curves shall be converted to true values as follows:

$s = \sigma(\varepsilon + 1)$ and $e = \ln(\varepsilon + 1)$ where s , e represent true stress and true strain and σ , ε represent engineering stress and strain. These correlation formulas are only valid up to the engineering UTS.

- for load controlled conditions see B103 and B109.

205 Determination of the applied stresses shall follow the following procedure:

- For uniaxial loading the nominal stress shall be determined from the nominal strain from the actual engineering “upper-bound” stress-strain curve. This stress is defined as the primary membrane stress, P_m , according to BS 7910.

For operational cases considering combined internal over-pressure and longitudinal strain see the instructions at the end of this paragraph.

- Assumptions of local displacement control involving relaxation of the stress level due to crack growth are not acceptable.
- The nominal stress shall be increased because of an assumed stress concentration factor (SCF) due to misalignment at the girth weld. The Neuber approach may be applied. The stress magnification is defined as a primary bending stress, P_b , according to BS 7910.

The SCF used in the ECA calculation for external flaws may be calculated according to DNV-RP-C203:

$$SCF = 1 + \frac{6\delta}{t} \cdot \frac{1}{1 + \left(\frac{T}{t}\right)^\beta} \cdot e^{-\alpha} \quad \text{Eq. A.2}$$

where

$$\alpha = \frac{1.82 \cdot L}{\sqrt{D \cdot t}} \cdot \frac{1}{1 + \left(\frac{T}{t}\right)^\beta} \quad \text{Eq. A.3}$$

$$\beta = 1.5 - \frac{1.0}{\log\left(\frac{D}{t}\right)} + \frac{3.0}{\left[\log\left(\frac{D}{t}\right)\right]^2} \quad \text{Eq. A.4}$$

T and t = Wall thickness of the pipes on each side of the girth weld, $T > t$

δ = Eccentricities (wall thickness differences, out-of-roundness, centre eccentricities etc.)

L = Width of weld cap

D = Outside diameter of pipe

It is acceptable to calculate the SCF with the following assumptions, see Figure 4:

$$\delta = \frac{hi / lo_{ROOT} + hi / lo_{CAP}}{2} \quad \text{Eq. A.5}$$

The hi/lo should be in accordance with Appendix D, Table D-4. However, weld contractors often specify a maximum value of hi/lo_{ROOT} which is smaller than the allowable hi/lo . This is acceptable but must be documented. Note that hi/lo_{ROOT} may be less than the misalignment.

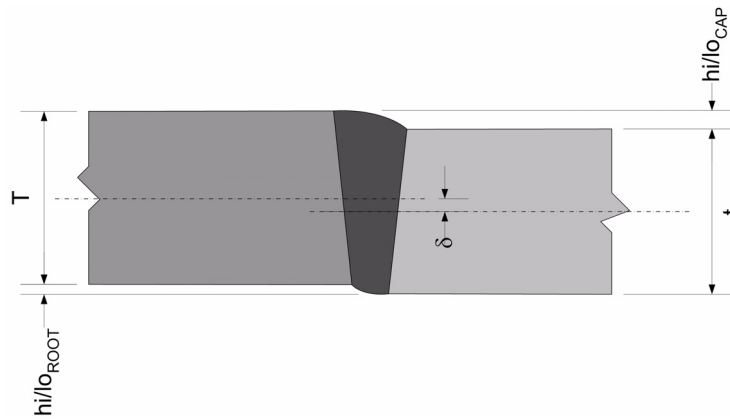

Figure 4
Illustration of how the maximum SCF may be assumed

The Neuber method was originally developed to assess strains at notches. It has been extensively used for pipeline girth welds subjected to plastic strains with good experience and has been adopted for use in this Appendix.

The Neuber method is defined by the following equation:

$$\sigma_2 \cdot \varepsilon_2 = \sigma_1 \cdot \varepsilon_1 \cdot SCF^2 \quad \text{Eq. A.6}$$

where

- SCF = elastic stress concentration factor
- σ_1 = nominal stress (excluding SCF)
- ε_1 = nominal strain (excluding SCF)
- σ_2 = actual stress (including SCF)
- ε_2 = actual strain (including SCF)

An illustration of the Neuber rule is shown in Figure 5.

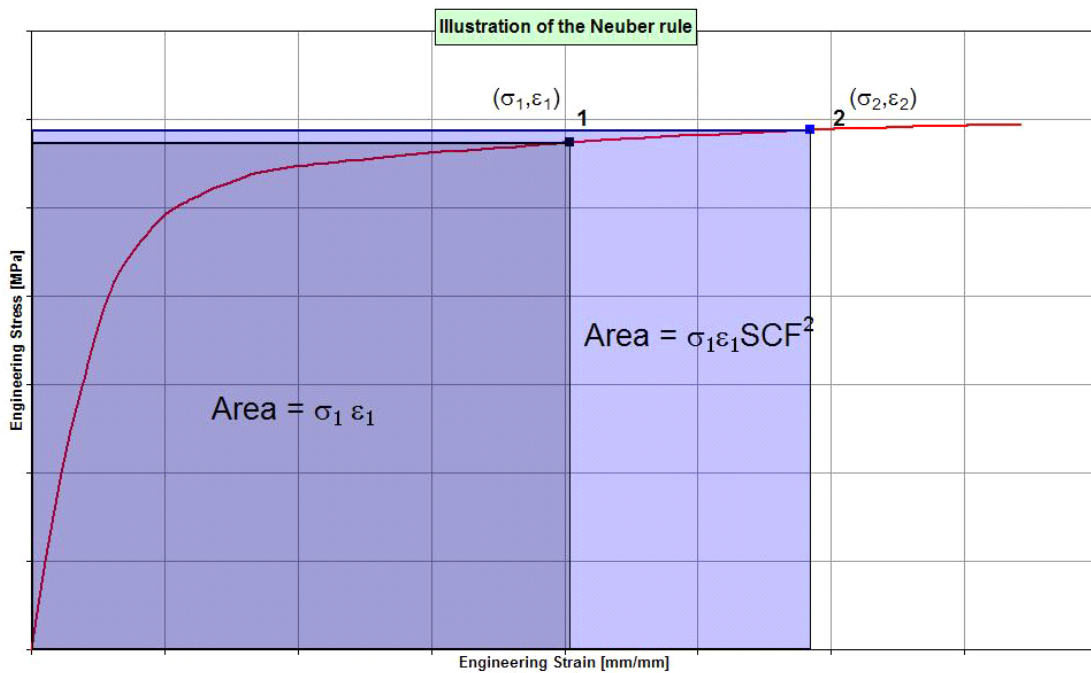

Figure 5
Illustration of the Neuber rule

- Normally, the local stress intensity magnification factor M_k is applied to welded connections. This increases the stress intensity factor to account for the presence of the weld toe. It is acceptable to exclude the M_k factor for pipeline girth welds if $\epsilon_{l,nom}$ is exceeding 0.4% provided the applied stress is defined according to the procedure specified above.
- If the difference in yield stress between adjacent pipes exceeds 100 MPa, see Sec.7, I303, or the wall thickness tolerances specified in Sec.7, Table 7-17 to Table 7-19, are not fulfilled, non-linear FE analyses shall be performed, either to determine correct applied stresses or to perform a Level 3C (3D FE fracture mechanics) assessment.
- Weld residual stresses shall be assumed for girth welds in the as-welded condition, see D111

Recent research has shown that the combination of internal over-pressure and longitudinal loading may be more onerous than longitudinal loading alone. However, there is currently no validated and generally accepted procedure for assessing the combined loading and each case shall be evaluated separately and the procedure accepted by all parties.

The research results indicate that the reduction in strain capacity is caused by an increase in the crack driving force (applied J or applied CTOD) but that the material fracture toughness is not influenced. This means that if the crack driving force is determined from dedicated 3D FEA or well documented and validated research results it is acceptable to use SENT testing to determine the fracture resistance also for the combination of internal over-pressure and longitudinal loading.

For assessments of situations with longitudinal strains, $\epsilon_{l,nom}$, equal to or less than 0.4% under internal over-pressure the applied stress, P_m , shall be determined as follows:

- The maximum bi-axial longitudinal stress in the pipeline based on FE analyses or
- Bi-axial longitudinal stress, σ_{b-a} , calculated as:

$$\sigma_{b-a} = \frac{\sigma_h}{2} + \sqrt{\sigma_{u-a}^2 - \frac{3}{4}\sigma_h^2} \quad \text{Eq. A.7}$$

where

- σ_{u-a} = Uni-axial longitudinal stress determined from $\epsilon_{l,nom}$ and the uni-axial stress-strain curve
- σ_h = Hoop stress

The true uni-axial stress-strain curve shall be used to define the FAD.

206 The reference stress, σ_{ref} , shall be calculated according to the plate solution, see BS 7910 (P.2). See also Table A-7.

Guidance note:

It is acceptable to use other reference stress solutions than specified in Table A-7 if those are proven to be accurate compared with 3D FE fracture mechanics analyses. In such cases it is acceptable to define the weld residual stress in accordance with E206.

---e-n-d---of---G-u-i-d-a-n-c-e---n-o-t-e---

207 The stress intensity factor shall be assessed using the plate solution for surface flaws in accordance with BS 7910. See also Table A-7.

208 The Failure Assessment Diagram (FAD) cannot be extended to arbitrarily large plastic deformations and a cut-off limit (referred as L_r cut-off or $L_{r,max}$) for the L_r ($L_r = \sigma_{ref}/YS$) axis must be defined.

It is acceptable for strain-based assessments to define the L_r cut-off value as true UTS/YS of the parent pipe representing the upper-bound stress-strain curve for the correct material condition, see D204 and Subsection G.

209 The J R-curves (or CTOD R-curves) to be used in a Level 3B assessment according to this Appendix shall be a lower bound to all J- Δa test data. It is not acceptable for experimentally derived J- Δa (or CTOD- Δa) test points to be lower than the J R-curve applied in the assessment.

210 It is recommended that the accumulated tearing from all installation strain cycles (not including fatigue) does not exceed 1 mm and the tearing assessed for one strain increment in the ECA shall not exceed the maximum tearing measured for the SENT specimens. In cases where the tearing capacity is demonstrated to be very good, more than 1 mm tearing may be allowable.

Guidance note:

The recommended limitation to tearing during installation is to avoid tearing instability with some safety margin. However, if the safety margin is shown to be large based on evaluation about loading mode, tearing resistance, flaw size and pipe geometry larger tearing may be reasonable. The critical tearing associated with one particular strain cycle shall always be at least 1.5 times the tearing allowed for, for that particular strain cycle.

---e-n-d---of---G-u-i-d-a-n-c-e---n-o-t-e---

211 If a Level 2B assessment is performed (no fracture toughness resistance curve), the critical J (or CTOD) shall be defined based on the fracture toughness testing as follows:

<i>Number of fracture toughness results</i>	<i>Equivalent fracture toughness value</i>
3 to 7	Lowest
8 to 12	Second lowest
13 to 17	Third lowest

All test results shall represent one homogeneous group (identical microstructure and testing conditions etc.) and the requirements of BS 7910 Annex K.2.3 shall be satisfied.

E. Use of Finite Element (FE) Fracture Mechanics Analyses to Assess Maximum Allowable Flaw Sizes

E 100 General

101 It may be acceptable to assess maximum allowable flaw sizes based on FE fracture mechanics analyses, but in such cases the safety margin might not be the same as if the procedure specified in Subsection D was used. If FE fracture mechanics analyses are applied the probability for fracture shall be evaluated and substantiated to satisfy the target safety class, see Sec.2 Table 2-5. A detailed procedure for how FE fracture mechanics analyses shall be performed has not been established and the procedure should be project specific.

102 In general 3D FE fracture mechanics analyses are recommended. Use of other dedicated software programs is acceptable if the geometry and flaw sizes assessed are benchmarked against dedicated 3D FE fracture mechanics analyses fulfilling the requirements specified in this Subsection. The use of such tools shall also include increase in CDF due to possible weld misalignments and weld residual stresses and the accuracy of CDF magnification must be justified. Some general guidance and requirements to 3D fracture mechanics analyses are given in E200.

E 200 FE model

201 When FE fracture mechanics analyses simulating strain-based loading is performed and were the maximum allowable flaw sizes are to be determined one of the following procedures are recommended:

- A minimum of 3 FE analyses with stationary flaws with different heights but equal length are performed and the CDF is plotted vs. the flaw height. The instability point may then be determined as the tangency point between the curve based on the FE predictions and the tearing resistance curve established by testing of the relevant material condition
- A FE analysis simulating crack growth for instance the Gurson-Tvergaard-Needleman formulation.

202 The CDF is dependent of the model quality. In order to get accurate results it is important that:

- The mesh refinement is adequate and validated as necessary
- Appropriate elements are selected
- The material stress-strain properties are defined accurately
- The total model length is reasonable.

203 For strain-based loading an upper-bound stress-strain curve with little strain hardening shall be basis for the stress-strain curve assigned to the parent pipe material, see D204. The weld metal stress-strain curve shall be lower-bound. For stress-based loading both the parent pipe material and the weld metal stress-strain curves shall be lower-bound.

204 The applied strain may be defined either based on the rotation of the pipe ends or as the strain at the outer curvature approximately at mid distance between the notch and the pipe end. For reeling installations etc. it is acceptable to simulate that the pipe is bent against a former with the actual radius.

205 It is acceptable to use FE fracture mechanics analyses as basis for adjusting the procedure for calculating the crack driving force and then to perform the adjusted ECA in accordance with the remaining parts of Subsection D. Possible solutions may be to change the stress-strain curve used in the ECA, to change the applied stresses, to use another reference stress solution or a combination. If this approach is used the accuracy of the CDF according to the selected procedure shall be compared with CDF determined from 3D FE fracture mechanics analyses.

206 For the final ECA which will have more accurate CDF calculations than predicted according to the Subsection D procedure it is acceptable to define the weld residual stress as an additional strain defined as YS/E which in most cases will be less conservative.

207 Possible weld misalignment shall be accounted for. If the FE fracture mechanics analyses are used to

adjust the CDF, see 205, and a perfect pipe without misalignment is modelled, possible misalignments shall be included according to D205.

208 If FE crack growth simulations are performed the Gurson-Tvergaard-Needleman formulation is recommended. Any crack growth model must be calibrated against relevant experimental results (e.g. SENT results and tensile testing).

F. Girth Welds Assessed According to ECA Fatigue

F 100 General

101 If A106 is fulfilled, no further assessments are required.

102 Fracture mechanics based fatigue assessments in the high-cycle regime shall be based on BS 7910 or equivalent procedures.

Guidance note:

High-cycle loading is normally understood to be cycles of more than around 1000 and stress ranges in the elastic regime.

---e-n-d---of---G-u-i-d-a-n-c-e---n-o-t-e---

103 Mean plus two standard deviation fatigue crack growth curves representing the relevant environment shall be used.

For embedded defects in pipelines not classified as sour it is acceptable to use air data until the crack extends through the ligament and becomes a surface crack when the relevant environmental data shall be used.

Residual stresses shall be included by applying the fatigue crack growth curves for $R \geq 0.5$.

104 External and internal surface flaws in addition to embedded flaws 3 mm beneath the external surface should be assessed. The different flaw sizes shall be defined equal to the applicable AUT defect acceptance criterion including the flaw sizing error and the flaws shall not become unstable during any stage during the design life. How to perform the fatigue crack growth assessments are summarised in Table A-12.

Table A-12 Fatigue crack growth analyses		
Type of flaw	Crack growth law	M_k according to BS7910
External surface flaw	Either based on project specific testing or the BS7910 curves for marine environment with CP as relevant. Air curve acceptable if it can be proven that the external steel surface will never be exposed to sea water.	2D or 3D solution. L equal to the width of weld at external surface
Internal surface flaw	Either based on project specific testing or the most representative BS7910 curve available if proven conservative.	2D or 3D solution. L equal to the width of weld at external surface
Embedded flaw	The air curve is acceptable if it can be substantiated that the fatigue performance is not reduced due to the environment.	2D or 3D solution. L equal to the width of weld at internal surface

105 For external surface flaws SCF according to D205 shall be multiplied with the nominal stress ranges. It is acceptable to define the increased stress as additional stress ranges in bending. For internal surface flaws of single sided welds no SCF is required. Embedded flaws in the upper half of the wall thickness shall include a SCF as used for external surface flaws while no SCF is necessary for embedded flaws in the lower half of the wall thickness.

Guidance note:

Large surface breaking defects normally do not occur in modern high quality pipeline girth welds. If it can be substantiated that surface breaking defects are not present it is acceptable to assume the defects to be embedded with ligament height of 3 mm in the fracture mechanics based fatigue assessment.

If the actual defect location can be determined it is acceptable to base the integrity assessment on the actual location.

---e-n-d---of---G-u-i-d-a-n-c-e---n-o-t-e---

106 Possible stable crack growth (ductile tearing) and fatigue crack growth shall be considered in the assessment. The assessment shall confirm that the largest weld defects expected to remain after NDT and repair will not increase during pipe laying to an extent such that fracture or fatigue failure will occur during operation of the pipeline, see also B107.

107 If the fatigue crack growth analyses are combined with maximum stress or strain assessments and other different fatigue load cases, for instance a combination of tearing during installation, possible fatigue because of a stop during laying and different fatigue scenarios from lateral buckles or free spans in the post-lay phase, it is acceptable to base the combined assessments on probabilistic analyses. A common and agreed procedure for how this should be performed does not exist and, hence, such procedure will be project specific and must be accepted and agreed by all parties.

If it can be substantiated that the probability of combining two different load cases is less than 10^{-3} it is acceptable not to combine them. However, all load cases shall be proven to have acceptable fracture limit state assuming weld flaws equal to the AUT acceptance criteria plus the defined flaw sizing error in accordance with Appendix E, see also B107.

108 If allowable defect sizes are determined by ECA in accordance with Subsections C or D, or for any other reason are larger than specified in Appendix D, the fatigue life assessment shall be based on S-N curves validated for the allowable defect sizes (see Sec.5 D808) or assessed based on fracture mechanics in accordance with this Subsection.

As crack initiation is not included in the fracture mechanics approach, shorter fatigue lives are normally derived from fracture mechanics than by S-N data. However, a well-defined and validated procedure for including a possible initiation period in the fracture mechanics fatigue approach does currently not exist. It is acceptable to perform the fracture mechanics fatigue crack growth assessments without any safety factor on the fatigue life calculated (i.e. DFF=1).

If fracture integrity analyses of known detected flaws are performed the DFF shall be defined as half of the values specified in Sec.5 Table 5-11.

109 The critical flaw size shall be determined according to Subsection D and E as relevant and considered when the fatigue life is determined. The fatigue assessment shall be performed using the relevant fatigue loading and fatigue crack growth law to determine the fatigue life from the initial defect size and until the critical defect size is reached.

If satisfactory fatigue life cannot be demonstrated or there is a risk of unstable fracture before or at the end of the operational life, either the weld defect acceptance criteria shall be reduced or actions to reduce the fatigue loading shall be taken. Where fatigue crack growth is predicted to be less than 0.2 mm, it can be assumed to be negligible.

110 The fatigue assessment shall consider all loading relevant to the design case, e.g. vortex induced vibration (VIV), bending stresses due to spanning, and varying longitudinal stresses due to thermal expansion and contraction.

Due to possible residual stresses from welding or plastic deformation during installation or operation the compressive part of cyclic stresses may contribute to the fatigue crack growth and the whole stress range shall be considered in the assessment.

111 It is acceptable to define the fatigue stress distribution through the wall thickness based on FE analyses provided that the analyses are well documented.

112 The thickness of the pipe wall shall be defined according to D202, first and second bullet points. In case of life extension assessments the wall thickness of the pipe shall be reduced by the full corrosion allowance. If reliable wall thickness measurements are available it is acceptable to base the assessment on such measurements.

113 For lined or clad pipelines, the fatigue life shall be assumed equal to the time necessary to grow through the clad/liner thickness. Possible initial weld defects shall be assumed as relevant.

F 200 Low-cycle fatigue

201 Possible low-cycle fatigue shall be assessed. However, a well-defined, validated and generally accepted procedure for the assessment of low-cycle fatigue in pipeline girth welds does currently not exist.

Any method used for assessing low-cycle fatigue shall therefore be justified, well documented and agreed by all parties.

Guidance note:

Low-cycle loading is normally understood to be cycles less than around 1000 and stress/strain ranges in the elastic-plastic regime.

---e-n-d---of---G-u-i-d-a-n-c-e---n-o-t-e---

G. Testing Requirements

G 100 General

101 Fracture toughness testing shall be performed on the materials and material conditions specified in Table A-13.

102 Tensile testing shall be performed on the materials and the material conditions specified in Table A-14.

103 Mechanical testing, fracture mechanics testing and pre-straining shall be performed according to this Subsection and Appendix B.

104 The extent of fracture mechanics testing and tensile testing for the different ECA categories shall be as specified in Table A-2 and Table A-8 respectively. All notch positions specified in Appendix B should be tested and exceptions must be thoroughly evaluated and documented.

105 It is not acceptable to base the ECA on tensile and fracture toughness test results from other pipeline projects only. Separate testing of all relevant weld procedures shall be performed for each project. Separate tensile and fracture toughness testing in accordance with Tables A-2, A-8, A-13 and A-14 shall normally be performed on all pipe dimensions used within a pipeline project.

Table A-13 Required material condition and test temperature for fracture toughness testing				
<i>ECA Category</i>	<i>Material condition to be tested</i>	<i>Test temperatures³⁾</i>		
		A	B	C
ECA Static, $\epsilon_{l,nom} < 0.4\%$ during both installation and operation	As-received	T_{min}	RT	T_{max}
ECA Static, $\epsilon_{l,nom} \geq 0.4\%$ during installation ¹⁾	As-received	T_{min}	RT	T_{max}
ECA Static, $\epsilon_{l,nom} \geq 0.4\%$ during operation	Pre-strained and aged ²⁾	T_{min}	RT	T_{max}
Assessment temperatures in consideration:				
A Minimum temperature, $T_{min} < 0^{\circ}C$				
B Minimum temperature, $0^{\circ}C \leq T_{min} \leq 50^{\circ}C$ for C-Mn and 13Cr pipelines				
B Minimum temperature, $0^{\circ}C \leq T_{min} \leq 20^{\circ}C$ for 22Cr and 25Cr pipelines				
C Maximum temperature, $T_{max} > 50^{\circ}C$ for C-Mn and 13Cr pipelines				
C Maximum temperature, $T_{max} > 20^{\circ}C$ for 22Cr and 25Cr pipelines				
1) If pipelines are installed as illustrated in Figure 8 b), it is acceptable to pre-compress all material prior to testing				
2) See G204				
3) If the load condition considered is realistic for a wide temperature range, testing at both minimum and maximum temperature shall be performed. For instance if the temperature range is between $0^{\circ}C$ and $60^{\circ}C$, both $0^{\circ}C$ (or RT) and $60^{\circ}C$ shall be tested. If the temperature range is between $-20^{\circ}C$ and $100^{\circ}C$ both temperatures shall be tested. It is the combination of the loading and the relevant temperature that must be considered. Hence, it is not necessarily the minimum or maximum design temperatures that shall be tested, see also B104.				

Table A-14 Required material condition and test temperature for tensile testing				
<i>ECA Category</i>	<i>Material condition to be tested</i>	<i>Test temperatures³⁾</i>		
		A	B	C
ECA Static, $\epsilon_{l,nom} < 0.4\%$ during both installation and operation	As-received	T_{min}	RT	T_{max}
ECA Static, $\epsilon_{l,nom} \geq 0.4\%$ during installation ¹⁾	As-received	T_{min}	RT	T_{max}
ECA Static, $\epsilon_{l,nom} \geq 0.4\%$ during operation	Pre-strained and aged ²⁾	T_{min}	RT	T_{max}
Assessment temperatures in consideration:				
A Minimum temperature, $T_{min} < 0^{\circ}C$				
B Minimum temperature, $0^{\circ}C \leq T_{min} \leq 50^{\circ}C$ for C-Mn and 13Cr pipelines				
B Minimum temperature, $0^{\circ}C \leq T_{min} \leq 20^{\circ}C$ for 22Cr and 25Cr pipelines				
C Maximum temperature, $T_{max} > 50^{\circ}C$ for C-Mn and 13Cr pipelines				
C Maximum temperature, $T_{max} > 20^{\circ}C$ for 22Cr and 25Cr pipelines				
1) If pipelines are installed as illustrated in Figure 8 b), it is acceptable to pre-compress all material prior to testing				
2) See G204				
3) If the load condition considered is realistic for a wide temperature range, testing at both minimum and maximum temperature shall be performed. For instance if the temperature range is between $0^{\circ}C$ and $60^{\circ}C$ both $0^{\circ}C$ (or RT) and $60^{\circ}C$ shall be tested. If the temperature range is between $-20^{\circ}C$ and $100^{\circ}C$ both temperatures shall be tested. It is the combination of the loading and the relevant temperature that must be considered. Hence, it is not necessarily the minimum or maximum design temperatures that shall be tested, see also B104.				

Guidance note:

The tensile properties and the shape of the stress-strain curve are important and have a strong effect on the critical flaw dimensions. Experience shows that for strain based assessments the tensile properties are sensitive to test temperature and pre-straining and ageing history. Conservative values of the critical flaw dimensions are determined using higher yield strengths and low strain hardening.

---e-n-d---of---G-u-i-d-a-n-c-e---n-o-t-e---

106 For pipeline materials susceptible to environmentally induced embrittlement the mechanical, fracture toughness and fatigue properties shall reflect the actual environment, see also A304. If tensile testing, fracture toughness testing and crack growth testing is performed under representative environmental and loading

condition, the assessment procedure described in Subsection E and F are applicable.

107 The corresponding CTOD fracture toughness can be estimated from the J fracture toughness according to the following formulas:

$$CTOD_{mat} = \frac{J_{mat}}{X \cdot YS \cdot (1 - \nu^2)} \quad \text{Eq. A.8}$$

where

- YS = The yield stress
- X = Conversion factor satisfying A403

Identical ECA results will be obtained if the same yield stress is used in the $CTOD_{mat}$ calculation as in the ECA analysis.

G 200 Straining and ageing

201 For strain-based ECAs, upper-bound tensile properties with low strain hardening shall be assessed and tested. For stress-based ECAs, lower-bound tensile properties shall be assessed and tested. To achieve this it may be necessary to pre-strain and age the material prior to testing. Pre-straining and ageing is normally not required for ECA Static considering installation, see also 204.

If aging is relevant, artificial ageing at 250°C for one hour shall be performed prior to any tensile testing. The ageing shall be performed after the pre-straining but before the tests are performed.

202 There are three important material mechanisms that must be considered when the pre-straining and aging procedure is established. These are:

- The “Bauschinger effect”, as illustrated in Figure 6
- Strain hardening, as illustrated in Figure 7
- Aging.

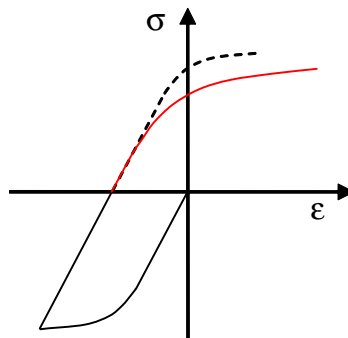

Figure 6
 The Bauschinger effect is a phenomenon which occurs when materials are strained into the non-linear stress-strain area in one direction followed by straining in the opposite direction. The effect of such cycling is that the reversed yield stress is decreased

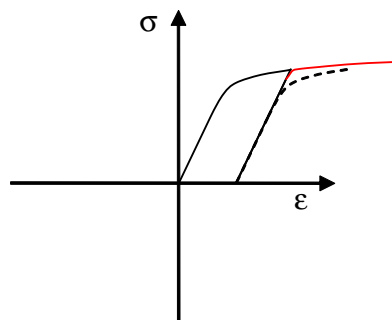
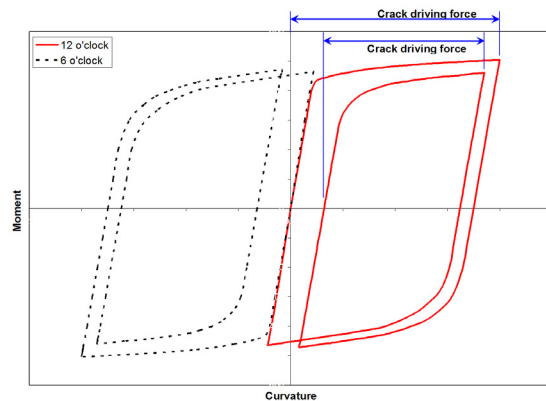
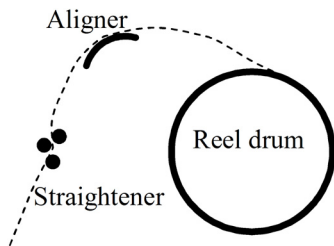

Figure 7
 Cyclic strain hardening is the effect seen if a material is strained in one direction followed by unloading before the material is strained in the same direction once more. The effect of such cycling is that the yield stress is increased and that the strain-hardening is decreased

203 Figure 8 illustrates the moment/curvature cycles for two different installation methods introducing large plastic strains.

For reeling installation, Figure 8 a), the most critical situation is theoretically reeling-on at 12 o'clock because the tensile properties are represented by the highest stress-strain curve with little strain hardening. However, the strain increment may be larger at the 6 o'clock location in the straightener and this situation shall also be considered.

For other installation methods, it is important that the whole installation sequence is evaluated in order to determine the largest strain increment. In some cases it may be acceptable to pre-compress the material prior to tensile and fracture mechanics testing, e.g. the strain increment marked in Figure 8 b). In such cases ageing is not required.



a) Reeling installation

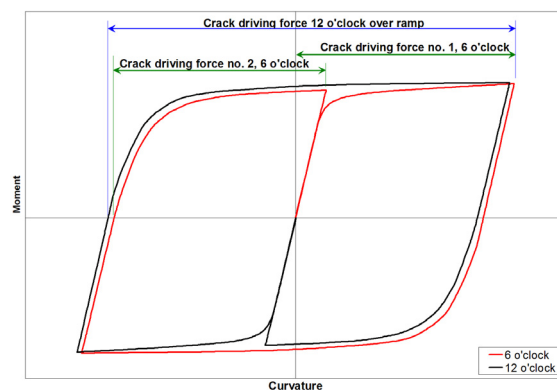
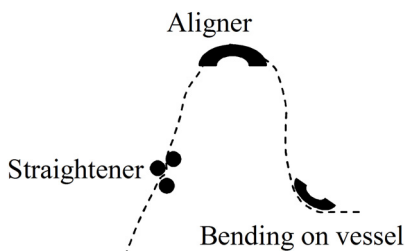

b) Installation method introducing large plastic strain increment

Figure 8 Examples of installation methods introducing large plastic strain increments

204 If the ECA includes situations where the pipeline has already been subject to plastic strains, the tensile testing and fracture mechanics testing shall be performed on material representing strained material with ageing if relevant. If it can be documented based on earlier experience that the fracture toughness properties are not reduced because of pre-straining and aging it is acceptable to perform fracture toughness testing in the as-received condition.

If the loading situation to be evaluated takes place more than one week after the material was plastically deformed during installation or operation, the tensile testing shall be performed on pre-strained and aged material.

If the load condition is strain-based, the pre-straining cycling shall end in tension because this will give upper-bound tensile properties and little strain hardening.

If the load condition is stress-based, the pre-straining cycling shall end in compression because this will give lower-bound tensile properties.

205 The pre-straining shall simulate one complete strain history (i.e. the whole installation sequence, but not contingency etc.) if ECAs are required for the operational phase.

H. ECA Validation Testing

H 100 General

101 Segment specimen testing or full scale testing shall be performed for the following situations where “ECA static” is applicable and more than one strain increments are applied:

- Clad or lined pipelines.
- C-Mn linepipe materials with SMYS larger than 555 MPa and $\epsilon_{1,\text{nom}} > 2.25\%$.
- 13Cr martensitic steels and $\epsilon_{1,\text{nom}} > 2.25\%$.
- 22Cr and 25Cr duplex stainless steels if $\epsilon_{1,\text{nom}} > 2.25\%$.

102 The segment testing shall be performed based on the procedure described in DNV-RP-F108 and Appendix B. The amount of testing and the strain cycles applied shall be agreed.

103 If segment testing is performed the dimensions of the starter flaw should be determined by an ECA tailored to the segment test prior to testing and based on the best estimate fracture resistance curve and stress-strain curve. The tip of the starter flaw should be in the lowest toughness material consistent with the ECA. The dimensions of the starter flaw should be such that approximately 0.5 mm of tearing (or as agreed) at the deepest point is predicted. If less tearing than estimated in the ECA is measured in the segment specimens and the stress capacity is at least as large as estimated by ECA, the ECA is considered validated.

APPENDIX B

MECHANICAL TESTING AND CORROSION TESTING

A. General

A 100 Objective

101 This appendix addresses methods for mechanical testing, chemical analysis and corrosion testing of materials and products.

A 200 Applicability

201 This appendix is applicable for the testing of all types of materials with testing requirements as referred to in this standard.

202 Test laboratories shall meet the requirements of ISO 17025 or an accepted equivalent.

A 300 References

301 The following standards are referred to in this Appendix:

API 5LD	Specification for CRA Clad or Lined Steel Pipe
API RP 5L3	Recommended Practice for Conducting Drop-Weight Tear Tests on Line Pipe
ASTM A264	Standard Specification for Stainless Chromium-Nickel Steel-Clad Plate
ASTM A 956	Standard Test Method for Leeb Hardness Testing of Steel Products
ASTM A 1038	Standard Test Method for Portable Hardness Testing by the Ultrasonic Contact Impedance Method
ASTM E110	Standard Test Method for Indentation Hardness of Metallic Materials by Portable Hardness Testers
ASTM E1820	Standard Test Method for Measurement of Fracture Toughness
ASTM G48	Standard Test Methods for Pitting and Crevice Corrosion Resistance of Stainless Steels and Related Alloys by Use of Ferric Chloride Solution
BS 7448	Fracture mechanics toughness tests. Method for determination of K_{Ic} , critical CTOD and critical J values of metallic materials
BS 7910	Guide to methods for assessing the acceptability of flaws in metallic structures
DNV-RP-F108	Fracture Control for Pipeline Installation Methods Introducing Cyclic Plastic Strain
ISO 148	Metallic materials - Charpy pendulum impact test
ISO 377	General requirements for the competence of testing and calibration laboratories
ISO 3183	Petroleum and natural gas industries - Steel pipe for pipeline transportation systems
ISO 4136	Destructive tests on welds in metallic materials - Transverse tensile test
ISO 5173	Destructive tests on welds in metallic materials - Bend tests
ISO 5178	Destructive tests on welds in metallic materials - Longitudinal tensile test on weld metal in fusion welded joints
ISO 6507	Metallic materials - Vickers hardness test
ISO 6892	Metallic materials - Tensile testing
ISO 7539	Corrosion of metals and alloys - Stress corrosion testing
ISO/TR 9769	Steel and iron - Review of available methods of analysis
ISO 12135	Metallic materials - Unified method of test for determination of quasistatic fracture toughness
ISO 14284	Steel and iron. Sampling and preparation of samples for the determination of chemical composition
ISO 15156	Petroleum and natural gas industries - Materials for use in H_2S -containing environments in oil and gas production
ISO 15653	Metallic materials, Method of test for the determination of quasistatic fracture toughness of welds
ISO 17025	General requirements for the competence of testing and calibration laboratories
NACE TM0177	Laboratory Testing of Metals for Resistance to Sulfide Stress Cracking and Stress Corrosion Cracking in H_2S Environments
NACE TM0284	Standard Test Method - Evaluation of Pipeline and Pressure Vessel Steels for Resistance to Hydrogen-Induced Cracking

B. Mechanical Testing and Chemical Analysis

B 100 General requirements to selection and preparation of samples and test pieces

101 Selection of samples and preparation of test pieces shall as far as applicable be in accordance with the general conditions of ISO 377. In addition the following requirements apply.

102 For any of the mechanical tests, any test piece that shows defective preparation or material imperfections unrelated to the intent of the particular mechanical test, whether observed before or after testing, may be discarded and replaced by another test piece from the same pipe.

Samples and test pieces from linepipe

103 For tensile tests, CVN impact tests, DWT tests, guided-bend tests, and flattening tests, the samples shall be taken, and the corresponding test pieces prepared, in accordance with the applicable reference standard.

104 Samples and test pieces for the various test types for linepipe shall be taken from alternating pipe ends in the locations as shown in Figure 5 and Figure 6 in ISO 3183 and as given in Sec.7 Table 7-9, and the details stated below.

Samples and test pieces from components

105 The location of samples and test pieces from components should be according to Sec.8 E.

106 For induction bends and bolts the location of samples and test pieces shall be according to the recognised standard or specification used for manufacture, as specified for the relevant component in Sec.8.

Samples and test pieces for welds not performed at pipe mills

107 For welds not performed as part of linepipe fabrication, including girth welds, samples shall be taken in accordance Appendix C Figure 1 and 2.

B 200 Chemical analysis

201 Samples for heat and product analyses shall be taken and prepared in accordance with ISO 14284. Methods and procedures for chemical analysis shall be according to recognised industry standards, of acceptable uncertainty. Results from chemical analyses shall be given with the same number of digits (or more) as given in the specification of the product and/or in this standard.

Guidance note:

ISO/TR 9769 gives a list of available international standards providing chemical analysis methods, with information on the application and precision of the various methods.

---e-n-d---of---G-u-i-d-a-n-c-e---n-o-t-e---

Chemical analysis of weld overlay

202 The chemical composition of the weld overlay shall be obtained at the surface of the overlay after machining of the overlay such that the minimum distance from the surface to the fusion line is either 3 mm or the minimum thickness specified for the finished component, whichever is the lesser.

B 300 Tensile testing

301 Tensile testing shall be carried out in accordance with the requirements in this appendix and ISO 6892 or ASTM A370. The test piece configuration and possible test piece flattening shall be the same for all the delivered items. The extensometer shall be attached to a machined surface. Double sided extensometers should be used.

Guidance note:

The elongation requirements in Table 7-5 are based on a formula identical in API 5L, ISO 3183 and DNV-OS-F101. The formula is calibrated for use with tensile test specimens prepared according to ASTM A370 (i.e. API test specimens). It should be noted that the same material tested with specimens based on ASTM A370 and ISO 6892 can give different elongation results due to the different specimen geometries.

In general it should be considered to use ASTM A370 specimens for normal tensile testing, since this would give the best correspondence with the requirements in Table 7-5.

Tensile specimens based on ISO 6892 can be used, but then the acceptance criteria should be reviewed. Some options are (i) use the values from Table 7-5, (ii) during qualification perform a number of tests on both types of specimens to establish an empirical correspondence for the specific material or (iii) define elongation criteria based on relevant testing experience and existing documentation.

---e-n-d---of---G-u-i-d-a-n-c-e---n-o-t-e---

302 Base material tensile properties may be determined using rectangular or round test pieces at the manufacturers discretion, see 303 and 304, respectively.

303 Rectangular test pieces shall represent the full wall thickness. Longitudinal/axial test pieces shall not be flattened. Transverse/tangential test pieces shall be flattened. Test piece grip ends may be flattened or machined to fit the test machine's grips. Weld beads may be ground flush and local imperfections may be removed.

304 Round test pieces shall be obtained from non-flattened samples. For longitudinal/axial tensile tests when $t \geq 19.0$ mm, such test pieces shall be 12.7 mm in diameter, or largest obtainable diameter if 12.7 mm is not possible. For transverse or tangential tensile tests the diameter of such test pieces shall be as given in Table 21 in ISO 3183, except that the next larger diameter may be used at the option of the manufacturer.

305 For testing when $D < 219.1$ mm full-section longitudinal/axial test pieces may be used at the option of the manufacturer.

306 If agreed, ring expansion test pieces may be used for the determination of transverse yield strength.

307 All weld tensile tests shall be carried out using round test pieces.

Guidance note:

All-weld tensile specimens are not required to conform to the sizes in Table 21 in ISO 3183, see 304 above. The all-weld tensile specimen shall be as large as possible when considering that the gauge length material shall be only weld metal.

Note that the grip area of the tensile specimens can contain material from the HAZ and also base metal. This will not influence the results for the weld metal on the gauge length.

---e-n-d---of---G-u-i-d-a-n-c-e---n-o-t-e---

308 For pipes to be tested according to supplementary requirement P and when ECA is to be performed, specimens shall be of proportional type with gauge length:

$$L_{gau} = 5.65\sqrt{S_o} \quad (B.1)$$

where S_o is the cross section area of the specimen. If the test results shall be used as basis for ECA, the whole stress-strain curve shall be reported.

Guidance note:

For supplementary requirement P additional tensile testing is required, and of particular interest is the elongation. The industry experience and qualification testing is primarily based on proportional specimens according to ISO 6892. Consequently the criteria have been established for such tensile specimens, and it is not relevant to use specimens based on ASTM A370 for supplementary requirement P.

---e-n-d---of---G-u-i-d-a-n-c-e---n-o-t-e---

Transverse weld (cross weld) tensile test

309 Test pieces shall be rectangular and in accordance with 303. The weld reinforcement shall be removed on the face and root sides by machining or grinding. The tensile strength shall be determined (yield stress and elongation is not required).

310 Transverse weld tensile test pieces of clad or lined linepipe shall be performed on the full thickness of the carbon steel, after removal of the CRA, taking care not to reduce the C-Mn steel wall thickness.

All-weld tensile testing of load bearing weld overlay

311 Test pieces shall be round with maximum obtainable diameter. The test pieces shall be machined from the weld overlay transverse to the welding direction.

Tensile testing of girth welds relevant for ECA

312 Full stress-strain curves shall be established from the testing. If possible, the test specimens shall either be all-weld specimens (recommended) or transverse all-weld specimens as follows:

- All-weld tensile specimens: The specimens should be round and of proportional type
- Transverse all-weld specimens: The recommended geometry is as indicated in Figure 13. If the weld metal portion of the specimen is instrumented with strain gauges, three strain gauges are recommended around the circumference. The width of the weld metal should be minimum 6mm. Possible yield plateau may be difficult to discover using this specimen type and the tensile stress-strain curve is typically 5% higher compared with results using traditional round specimens. Hence, if this specimen is used as input to FE analyses or for demonstrating weld metal strength, over-match the engineering stress shall be lowered 5%

If the weld and pipe geometry is such that it is difficult to establish stress-strain curves representing the weld metal, one of the following solutions shall be followed:

- Dedicated “special” specimens may be tested if possible, similar specimen geometry shall then be fabricated also from the parent pipe material
- Weld strength over-match with sufficient confidence may be demonstrated by cross-weld tensile testing
- If none of the above is possible and an ECA is required full-scale testing of representative “worst case” girth welds (i.e. geometry, material properties and weld defect) shall be tested to the worst case loading to demonstrate the fracture integrity

B 400 Charpy V-notch impact testing

401 The test pieces shall be prepared in accordance with ASTM A370 without any prior flattening of the material. Testing according to ISO 148-1 is acceptable if agreed and the required striking radius (2 or 8 mm) is specified. Each set shall consist of three specimens taken from the same test coupon. Full size test pieces shall be used whenever possible.

402 The size, orientation and source of the test pieces from linepipe shall be as given in Table 22 in ISO 3183, except that the next smaller test piece size may be used if the absorbed energy is expected to exceed 80% of the full-scale capacity of the impact testing machine. Additional sets of HAZ test pieces shall be sampled compared to ISO 3183, see Table 7-7 and Table 7-8 in Sec.7. The notch locations shall be according to 408-413.

Guidance note:

It is not necessary to impact-test linepipe with combinations of specified outside diameter and specified wall thickness not covered by Table 22 in ISO 3183.

---e-n-d---of---G-u-i-d-a-n-c-e---n-o-t-e---

403 For seamless pipe with $t > 25$ mm and delivered in the quenched and tempered condition, one additional set of transverse direction CNV test pieces shall be sampled 2 mm above the internal surface during MPQT.

404 The locations of test pieces taken from components shall be according to Sec.8 E.

405 The locations of test pieces taken from girth welds shall be according to Appendix C, Figure 2.

406 Whenever possible, and apart for testing of the root of double sided welds, the test pieces shall be sampled 2 mm below the external surface. A smaller distance than 2 mm shall be used if necessary (due to the dimensions of the material) to make specimens with the largest possible cross section. The axis of the notch shall be perpendicular to the surface.

407 For weld metal and HAZ tests, each test piece shall be etched prior to notching in order to enable proper placement of the notch.

Notch positioning for weld metal test pieces

408 For production welds other than HFW pipe the axis of the notch of the weld metal sample shall be located on, or as close as practical to, the centreline of the outside weld bead.

409 For test pieces taken in the weld of HFW pipe, the axis of the notch shall be located on, or as close as practical to the weld line.

Notch positioning for HAZ test pieces

410 The HAZ notch positions comprise the fusion line (FL), the FL+2 mm and the FL+5 mm test pieces shall be sampled in the positions given in Figure 3 to Figure 8, with the notch positions as applicable. FL test pieces shall always be located such that 50% of weld metal and 50% of HAZ is sampled.

411 Impact testing of clad/lined pipes shall be performed in the carbon steel portion of the material.

412 When dissimilar materials are welded, both sides of the weld shall be tested.

413 For weld overlay material contributing to the transfer of load across the base material/weld overlay fusion line, impact testing of the weld overlay and HAZ shall be performed (i.e. when the overlay is a part of a butt joint or acts as a transition between a corrosion resistant alloy and a carbon steel). The longitudinal axis of the specimen shall be perpendicular to the fusion line and the notch parallel to the fusion line.

B 500 Bend testing

Guided-bend testing of the seam weld of welded pipe

501 The test pieces shall be prepared in accordance with ISO 7438 or ASTM A370, and Figure 8 in ISO 3183.

502 For pipe with $t > 19.0$ mm, the test pieces may be machined to provide a rectangular cross-section having a thickness of 18.0 mm. For pipe with $t \leq 19.0$ mm, the test pieces shall be full wall thickness curved-section test pieces.

503 For SAW pipes, the weld reinforcement shall be removed from both faces.

504 The guided-bend test shall be carried out in accordance with ISO 7438. The mandrel dimension shall not be larger than that determined using the following equation, with the result rounded to the nearest 1 mm:

$$A_{gb} = \frac{1.15(D - 2t)}{\left(e \frac{D}{t} - 2e - 1\right)} - t \quad (\text{B.2})$$

where:

A_{gb} is the mandrel dimension, expressed in millimetres (inches)

D is the specified outside diameter, expressed in millimetres (inches)

t is the specified wall thickness, expressed in millimetres (inches)

e is the strain, as given in Table 23 of ISO 3183

1.15 is the peaking factor.

505 Both test pieces shall be bent 180° in a jig as shown in Figure 9 in ISO 3183. One test piece shall have the root of the weld directly in contact with the mandrel; the other test piece shall have the face of the weld directly in contact with the mandrel.

Bend testing of clad linepipe

506 Weld clad or roll bonded clad pipe shall be subjected to bend testing (the longitudinal weldment shall not be included). Specimens shall be of full thickness, including the full thickness of the clad layer. The width of the specimens shall be approximately 25 mm. The edges may be rounded to a radius of 1/10 of the thickness. The specimens shall be bent 180° around a former with a diameter 5x the pipe wall thickness.

507 Longitudinal weld root bend test shall include the corrosion resistant alloy.

- The longitudinal axis of the weld shall be parallel to the specimen, which is bent so that the root surface is in tension.
- The width of the longitudinal root bend specimen shall be at least twice the width of the internal weld reinforcement or maximum 25 mm. The edges may be rounded to a radius of 1/10 of the thickness.
- The internal and external weld reinforcement shall be removed flush with the original surfaces.
- The thickness of the specimen shall be equal to the base material thickness or a maximum of 10 mm, as shown in Figure 2.
- The specimen shall be bent to an angle of 180° using a former with diameter 90 mm.

Bend testing for WPQT according to Appendix C

508 Bend testing shall be performed in accordance with ISO 5173. Bend test specimens shall have full wall thickness. The width of root and face bend specimens shall be approximately 25 mm. The width of side bend specimens shall be 10 mm. The edges may be rounded to a radius of 1/10 of the thickness.

509 Bend test of clad pipes shall be performed on full thickness of the pipe, including the corrosion resistant alloy.

510 The weld reinforcement on both faces shall be removed flush with the original surfaces, as shown in Figure 1. The weld shall be located in the centre of each specimen.

511 The specimens shall be bent to an angle of 180° using a former with diameter depending on the specified minimum yield stress SMYS for the parent material. For materials with SMYS up to 415 MPa, the former diameter shall be 4x thickness of the test specimen. For materials with SMYS equal to or exceeding 415 MPa, the former diameter shall be 5x thickness of the test specimen.

512 If necessary, e.g. if one of the materials to be joined has a lower yield stress than the other, guided bend testing in accordance with ISO 5173 may be applied, using the same roller diameter as for the conventional bend testing.

513 After bending, the welded joint shall be completely within the tensioned region.

Bend testing of weld overlay

514 Side bend test specimens shall be used. The test specimens shall be sampled perpendicular to the welding direction.

- For pipes, the test specimens shall sample the full thickness of the weld overlay and the base material. For heavy section components, the thickness of the base material in the specimen shall be at least equal to 5x the thickness of the overlay.
- The thickness of side bend specimens shall be 10 mm. The edges may be rounded to a radius of 1/10 of the thickness. The central portion of the bend test specimen shall include an overlap area.
- The specimens shall be bent to an angle of 180°. For base materials with SMYS up to 415 MPa the former diameter shall be 4x thickness of the test specimen. For base materials with SMYS equal to or exceeding 415 MPa the former diameter shall be 5x thickness of the test specimen.

B 600 Flattening test

601 The test pieces shall be taken in accordance with ISO 8492, except that the length of each test piece shall be ≥ 60 mm. Minor surface imperfections may be removed by grinding.

602 The flattening test shall be carried out in accordance with ISO 8492. As shown in Figure 6 in ISO 3183, one of the two test pieces taken from both end-of-coil locations shall be tested with the weld at the 6 or 12 o'clock position, whereas the remaining two test pieces shall be tested at the 3 or 9 o'clock position. Test pieces taken from crop ends at weld stops shall be tested at the 3 or 9 o'clock position only.

B 700 Drop weight tear test

701 Drop weight tear test shall be carried out in accordance with API RP 5L3.

702 Full thickness specimens shall be used where possible. Reduced thickness specimens may be used subject to Purchaser agreement. The testing temperature reduction given in API RP 5L3 shall apply.

The specimens shall be taken transverse to the rolling direction or pipe axis, with the notch perpendicular to the surface.

For high toughness steels ductile crack initiation from the notch tip shall be acceptable (contrary to API RP 5L3, Clause 7.1).

B 800 Fracture toughness testing

801 For qualification testing of linepipe weld metal, see 804 and 813 to 815:

— for qualification testing of girth welds, see 816 to 820.

802 The fracture toughness testing applicable to this Standard is:

- Fracture toughness testing, J or CTOD (δ), a minimum of 3 specimens is required for each notch position.
- Fracture toughness resistance curve testing, J- Δa (J R-curve) or δ - Δa (δ R-curve), a minimum of 6 specimens is required for each notch position.

803 Fracture toughness testing should be performed using one of the following type of specimens:

- Single Edge Notched Tension (SENT), or
- Single Edge Notched Bend (SENB) specimen

Pipeline walls are predominately loaded in tension independent of the loading mode. The recommended specimen for such conditions is the SENT specimen, as shown in Figure 12. Refer also to DNV-RP-F108 for further guidance.

Guidance note:

Commonly used testing standards describe methods for determining the fracture resistance from deeply notched SENB (Single Edge Notched Bend) or CT (Compact Tension) specimens. These specimens, both predominantly loaded in bending, have high crack tip constraint and will hence give lower bound estimates for the fracture resistance that can be used for conservative fracture assessments for a large range of engineering structures. The SENB specimen can also be used but this is likely to result in unnecessarily conservative fracture toughness.

---e-n-d---of---G-u-i-d-a-n-c-e---n-o-t-e---

804 Fracture toughness testing as required in Sec.7 for weld metal shall be CTOD testing of SENB specimens.

805 Other test specimen configurations may be used for deriving the fracture toughness for use in an ECA provided that the fracture toughness can be derived from experimental measurement, e.g. load vs. clip gauge displacement and that it is justified that the crack tip constraint of the test specimen is not smaller than for the most severe pipeline weld defect assessed in the ECA.

806 Testing of SENB specimens shall be carried out in general compliance with the latest revisions of ISO 12135 and ISO 15653 or an equivalent standard.

All SENT testing shall be performed in accordance with DNV-RP-F108.

807 Post-test metallography shall be applied to the specimens designated for FL/HAZ testing in order to establish if the crack tip has been successfully located in the target microstructure.

The specimen is considered qualified if:

- the pre-crack tip is not more than 0.5 mm from fusion line
- grain coarsened heat affected zone (GCHAZ) micro-structure is present within a region confined by a plane perpendicular to the crack plane through the crack tip and a parallel plane 0.5 mm ahead of the crack tip.

Relevant for testing of SENB specimens

808 Testing of SENB specimens are acceptable, see 903, also with reduced notch length. However, for use in an ECA the specimen notch length shall not be chosen shorter than the height of the most severe weld defect assessed in the ECA.

The fracture toughness for SENB test specimens can be derived from the load vs. clip gauge displacement record according to the following formulae:

$$J = \frac{K^2(1-\nu^2)}{E} + \frac{\eta_{pl} \cdot A_{pl}}{B(W - a_o) \left(1 + \frac{\Delta a}{3(W - a_o)} \right)} \quad (B.3)$$

where

$$\eta_{pl} = 3.667 - 2.199\left(\frac{a_o}{W}\right) + 0.437\left(\frac{a_o}{W}\right)^2 \quad (\text{B.4})$$

where A_{pl} is the area under the load vs. crack mouth displacement (CMOD) curve. For definitions of the other parameters it is referred to BS 7448 and ASTM E1820 and Δa is the crack extension after testing.

809 If the total displacement, V_g , is measured at a distance $z \leq 0.2a$ from the physical crack mouth then the CMOD can be calculated from:

$$CMOD = \frac{V_g}{1 + \frac{z}{0.8a + 0.2W}} \quad (\text{B.5})$$

810 The CTOD-value, δ , can be calculated from J according Appendix A, G107.

Reporting of fracture toughness testing:

811 The following information shall be reported from J/CTOD testing:

- load vs. crack mouth opening displacement curves of all tests
- crack measurements (a_0)
- j or δ results
- test temperature
- material condition (possible pre-straining and aging history)
- welding procedure and weld metal designation
- parent pipe designation.

812 The following information shall be reported from J R-curve or δ R- curve testing:

- load vs. crack mouth opening displacement curves of all tests
- crack measurements (a_0 and Δa)
- J- Δa or δ - Δ
- a results
- test temperature
- material condition (possible pre-straining and aging history)
- welding procedure and weld metal designation
- parent pipe designation.

Fracture toughness testing of linepipe

813 The following applies to fracture toughness testing of linepipe as required during MPQT:

δ fracture toughness testing of the weld metal shall be performed using SENB specimens.

814 Testing shall be conducted on through thickness notched specimens with the specimen orientated transverse to the weld direction (the corresponding notation used by ISO 15653 is NP). The notch shall be located in the weld metal centre line.

815 The number of valid CTOD or J tests for each location shall be minimum 3. The characteristic CTOD or critical J value shall be taken as the lowest from 3 valid tests or selected in accordance with BS 7910. Only specimens that are qualified with respect to crack tip location by post-test metallographic examination shall be considered valid.

Qualification of girth welds (ECA)

816 The recommended specimen for fracture toughness testing of girth welds is the SENT (Single Edge Notched Tension) specimen. The calculation and performance of SENT testing shall be according to DNV-RP-F108.

817 The SENT specimens shall be designed with a Surface Notch (SN), since this is the relevant orientation for defects in the welds. The notch may be introduced either from the outer surface or from the inner surface.

818 The notch positions and welding procedures to be tested shall be agreed. Typically the main line procedure(s), the through thickness procedure(s) and the partial repair procedure(s) shall be tested as illustrated in Figure 9 and specified in Appendix A, Table A-2, Table A-8 and Table A-13.

Guidance note:

It is recommended that the FL/HAZ is notched from the outer surface. Such notching is empirically more successful because the crack growth tends to grow towards the base material. Hence, a crack tip at the FL boundary is typically growing through the HAZ if it is notched from the outer surface.

---e-n-d---of---G-u-i-d-a-n-c-e---n-o-t-e---

819 For situations involving plastic deformation and possibility of unstable fracture caused by tearing, crack resistance curve testing (preferably J R-curve) shall be performed of the girth weld. If the SENT specimen is tested, which is recommended, the testing shall be in accordance with DNV-RP-F108.

820 If segment testing is required, see Appendix A, H101, testing shall be performed based on DNV-RP-F108. The amount of testing and test procedure shall be adjusted to the loading considered.

B 900 Specific tests for clad and lined linepipe

901 Shear testing shall be performed in accordance with ASTM A264 (Standard Specification for Stainless Chromium-Nickel Steel-Clad Plate, Sheet and Strip).

902 Gripping force of lined pipe shall be measured by the residual compressive stress test, in accordance with Clause 7.3 b of API 5LD.

B 1000 Metallographic examination and hardness testing

Macro examination

1001 Macro examination shall be performed at 5× to 10× magnifications (for HFW the examination shall be performed at minimum 40× and be documented at 10× to 20× magnification). Macro examination shall be conducted on specimens given in Figures 10 and 11, as applicable. The macro section shall include the whole weld deposit and in addition include at least 15 mm of base material on each side measured from any point of the fusion line. The macro-section shall be prepared by grinding, polishing, and etched on one side to clearly reveal the fusion line and HAZ.

The macro examination of weld overlay shall be sampled transverse to the welding direction. The width of the macro section shall be minimum 40 mm. The face exposed by sectioning shall be prepared by grinding, polishing and etched by a suitable etchant to clearly reveal the weld and heat affected zone.

Microstructure examination

1002 Samples for optical metallography shall be prepared using standard procedures, and further etched using a suitable etchant in order to reveal the microstructure.

Micro examination of duplex stainless steels shall be performed and documented at a minimum magnification of 400X.

The ferrite content of the base material and weld metal shall be measured according to ASTM E562.

Hardness testing

1003 Hardness testing of base material and weld cross-section samples shall be carried out using the Vickers HV10 method according to ISO 6507-1.

1004 For pipe base material tests, individual hardness readings exceeding the applicable acceptance limit may be considered acceptable if the average of a minimum of three and maximum of six additional readings taken within close proximity does not exceed the applicable acceptance limit and if no such individual reading exceeds the acceptance limit by more than 10 HV10 units.

1005 Hardness test locations for SMLS pipe shall be as shown in Figure 10 a), except that:

- when $t < 4.0$ mm, it is only necessary to carry out the mid-thickness traverse
- for pipe with $4.0 \text{ mm} \leq t < 6$ mm, it is only necessary to carry out the inside and outside surface traverses.

1006 Hardness testing of welds shall be performed on the specimens used for macro examination, and as shown in Figures 10 b) and c), and Figure 11.

1007 For SAW, HFW and MWP the following applies:

- for pipe with $t < 4.0$ mm, it is only necessary to carry out the mid-thickness traverse
- for pipe with $4.0 \text{ mm} \leq t < 6$ mm, it is only necessary to carry out the inside and outside surface traverses.

1008 In the weld metal of SAW and MWP welds, a minimum of 3 indentations equally spaced along each traverse shall be made. In the HAZ, indentations shall be made along the traverses for each 0.5 - 1.0 mm (as close as possible but provided indentation is made into unaffected material, and starting as close to the fusion line as possible according to Figure 10 b).

1009 Hardness testing of clad/lined pipes shall have one additional hardness traverse located in the thickness centre of the CRA material. See Figure 11.

1010 For hardness testing of weld overlay hardness testing shall be performed at a minimum of 3 test locations: in the base material, in the HAZ and in each layer of overlay up to a maximum of 2 layers.

Surface hardness testing

1011 Surface hardness testing, e.g. of suspected hard spots detected by visual inspection, shall be carried out in accordance with ISO 6506, ISO 6507, ISO 6508 or ASTM A370 using portable hardness test equipment. Depending on the method used the equipment shall comply with ASTM A956, ASTM A1038 or ASTM E110.

B 1100 Straining and ageing

Ageing test

1101 This test is applicable if the cold forming during pipe manufacture of C-Mn and clad/lined steels exceeds 5% strain and for Supplementary requirement F. This test does not apply to linepipe delivered with a final heat treatment (e.g. normalising or quench and tempering).

A test coupon shall be machined from the pipe material and aged at 250°C for one hour. Thereafter, the specified number of Charpy V-notch specimens shall be machined from the middle of the coupon. The orientation of the specimens shall be longitudinal to the coupon centreline, with the notch perpendicular to the surface of the test coupon.

Pre-straining and ageing of materials

1102 Pre-straining is applicable to:

- Linepipe material to be qualified in accordance with Supplementary requirement P.
- Girth welds to be qualified in accordance with Appendix A (ECA).

1103 Pre-straining can be carried out as full scale (reversed) bending of whole pipes sections or as tension/compression straining of material cut from the pipe wall (segment specimens).

1104 When full scale bending is applied whole pipes sections they shall be instrumented with strain gauges on the outside of the pipe wall in the 12 and 6 o'clock positions, see Figure 14 a). A sufficient number of strain gauges shall be fitted along the length of the test section to ensure an efficient monitoring of the strain along the whole test section. If reeling installation is simulated it is recommended to bend the pipe against formers with the correct radiuses.

1105 When pre-straining cut material such material shall be fitted with strain gauges on each of the opposite sides with respect to the smallest measure on the cross section, see Figure 14 b). A sufficient number of strain gauges shall be fitted along the length of the test section to ensure an efficient monitoring of the strain along the whole test section. If the test machine is not sufficiently rigid, strain gauges shall also be fitted either sides along the long cross section.

1106 The strain gauges shall be logged with sufficient frequency during the straining cycle to ensure efficient monitoring of the cycle.

1107 The pre-straining shall be carried out in such a way that the characteristic strain (see below) reaches at least the strain levels to be simulated.

1108 The characteristic strain shall for cut material (segments or strip specimens) be defined as the mean value of the strains measured on the outside and inside of the pipe side with the highest strain. For full scale bending of spool pieces/pipe sections the characteristic strain should be achieved by bending against a former with the actual radius. If a former is not used the material which will be used for later material testing shall at least reach the target strain (characteristic strain), where the strain is measured at the outer curvature.

1109 The differences between strain gauges may be large due to buckling of the segment/strip specimens during compression. If fracture toughness testing of the FL shall be performed from a strained specimen the FL against the parent pipe with strain level equal to the target strain shall be tested.

1110 After straining for Supplementary requirement P, the samples shall be artificially aged at 250°C for one hour before testing. Regarding artificial ageing for ECA, see Appendix A G200.

B 1200 Testing of pin brazings and aluminothermic welds

Copper penetration

1201 2 test specimens shall the sectioned transverse to the anode lead and 2 test specimens parallel with the anode lead. The specimens shall be prepared and etched for metallographic examination. The examination shall be performed at a magnification of 50X. The fusion line of the weld/brazing shall at any point not be more than 1.0 mm below the base material surface. Intergranular copper penetration of the base material shall not at any point extend beyond 0.5 mm from the fusion line.

Hardness

1202 HV10 hardness tests shall be made on each of the specimens for copper penetration measurements. A traverse shall be made across the weld/brazing zone. The traverse shall consist of minimum 10 indentations; two in the heat affected zone (HAZ) on each side of the weld/brazing, two in the HAZ under the weld/brazing and two in the base material on each side of the weld/brazing. The HAZ indentations shall be made as close to the fusion line as possible.

1203 The maximum hardness shall not exceed the limits given in Appendix C as applicable for the intended service and type of material.

Pull test

1204 The test specimen shall be mounted in a tensile testing machine and secured in the cable in one end and the base material in the other end. Force shall be applied until the specimen breaks. The specimen shall break in the cable.

C. Corrosion Testing

C 100 General

101 For certain material and fluid combinations where improper manufacture or fabrication can cause susceptibility to corrosion related damage, the need for corrosion testing during qualification and/or production of materials shall be assessed. Certain corrosion tests are further applicable to verify adequate microstructure affecting toughness in addition to corrosion resistance. This subsection describes test requirements and methods for corrosion testing.

C 200 Pitting corrosion test

201 This test is applicable to verify CRAs' resistance to pitting and crevice corrosion by oxidising and chloride containing fluids, e.g. raw seawater and other water containing fluids (including treated seawater) with high residual contents of oxygen and/or active chlorine. For duplex stainless steels, this test is further applicable to verify adequate microstructure after manufacturing or fabrication (see B101).

202 Testing shall be carried out according to ASTM G48, Method A.

203 Location of specimens is given in Appendix C, Figures 1 and 2.

204 The minimum recommended size of test specimens is 25 mm wide by 50 mm long by full material thickness (except as allowed by 205). For welds, at least 15 mm of the base material on each side of the weld shall be included in the test specimen.

205 Test specimens from clad/lined pipe shall be machined to remove the carbon steel portion and are to contain the full weld and any heat affected zone in the corrosion resistant alloy. The specimen thickness shall as a minimum be 1 mm where one of the surfaces is representing the inside of the pipe.

206 Rolled surfaces shall be tested "as-received", i.e. without mechanical preparation. The root and the cap side of the welds are only to be prepared with the intention of removing "loose material" that will interfere with weighing prior to and after testing. Cut faces shall be ground (500 grid) and sharp edges smoothed off. The specimen shall subsequently be pickled to reduce the susceptibility of cut surfaces to end-grain attack. For duplex stainless steels and austenitic grades with PRE > 30, 20% nitric acid + 5% hydrofluoric acid, 5 minutes at 60°C is adequate.

207 The test solution shall be prepared according to the referenced standard.

Corrosion testing of weld overlay

208 Specimens for corrosion testing of the weld overlay shall be machined from the base material side. The remaining surface of the specimen shall be representative for the weld overlay at the minimum distance from the fusion line (equal to 3 mm or the minimum weld overlay thickness specified for the finished machined component, whichever is the lesser). The opposite surface of the specimen shall be machined such that the thickness of the specimen is 2 mm. The size of the specimen shall be 25 × 25 mm in length and width.

C 300 Hydrogen induced cracking test

301 Testing for Hydrogen Induced Cracking (HIC), also referred to as StepWise Cracking (SWC), as defined in ISO 15156 is applicable to rolled C-Mn steel linepipe and pipeline components. Testing shall be according to ISO 15156-2, B.5 (referring to NACE TM0284).

302 Tests should be conducted in a medium complying with NACE TM0284, Solution A.

If agreed, tests may be conducted:

- in 5% mass fraction NaCl + 0.4 mass fraction CH₃COONa and pH adjusted to required value using HCl or NaOH (see ISO 15156-2:2003, Table B.3)
- with a partial pressure of H₂S appropriate to the intended application
- with acceptance criteria that are equal to or more stringent than those specified in Sec.7 I110.

Values of crack length ratio, crack thickness ratio, and crack sensitivity ratio shall be reported. If agreed, photographs of any reportable crack shall be provided with the report.

C 400 Sulphide stress cracking test

Qualification of new materials

401 For qualification of new materials (i.e. not listed for H₂S service in ISO 15156-2/3), testing shall be conducted on specimens from at least 3 heats of material. Qualification testing shall include testing of simulated girth welds and for welded pipe also seam welds, in addition to longitudinal samples of the base material. Specimen preparation, testing procedures and acceptance criteria shall comply with ISO 15156, using triplicate specimens for each testing condition (i.e. heat of material and environment).

402 Materials listed for H₂S service in ISO 15156 but not meeting the requirements in Sec.7 I100, (e.g. maximum hardness or contents of alloying or impurity elements) may be qualified by testing for resistance to Sulphide Stress Cracking (SSC) as specified in C401, except that testing shall be carried out on material

representing the worst case conditions to be qualified (e.g. max. hardness or max. sulphur content).

Qualification of pipe manufacturing

403 As an option to Purchaser, SSC testing may be carried out for qualification of pipe manufacturing. One longitudinal base material sample shall be taken from each test pipe.

404 For welded linepipe, testing shall include one additional sample transverse to the weld direction (samples W or WS according to Figure 5 in ISO 3183) and shall contain a section of the longitudinal or helical seam weld at its centre.

405 Three test pieces shall be taken from each sample. Test pieces for four-point bending SSC tests should be ≥ 115 mm long \times 15 mm wide \times 5 mm thick. Samples may be flattened prior to machining test pieces from the inside surface of the pipe.

406 Tests should be performed in accordance with NACE TM0177, using Test Solution A. A four-point bend test piece in accordance with ISO 7539-2 shall be used and the test duration shall be 720 h. The test pieces shall be stressed to a fraction of AYS appropriate for the pipeline design, however minimum 80% of the material AYS.

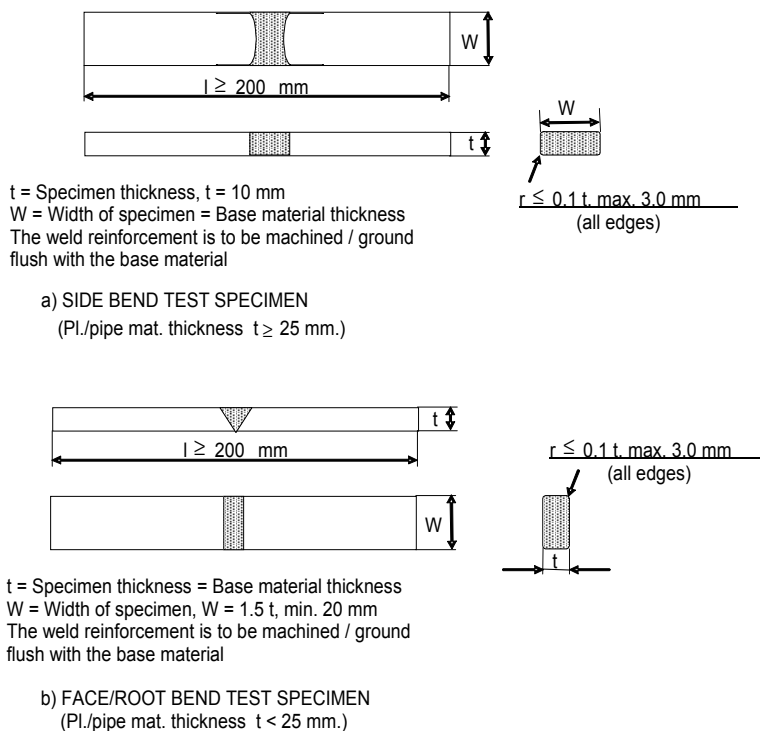

Figure 1
Bend test specimens

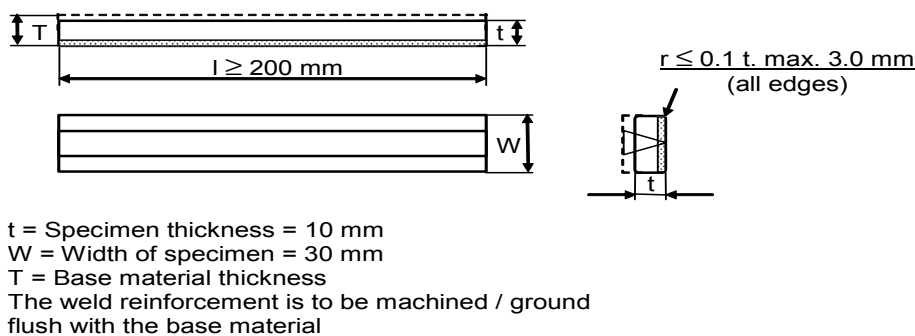
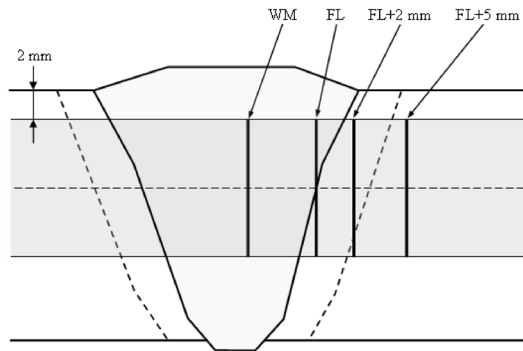
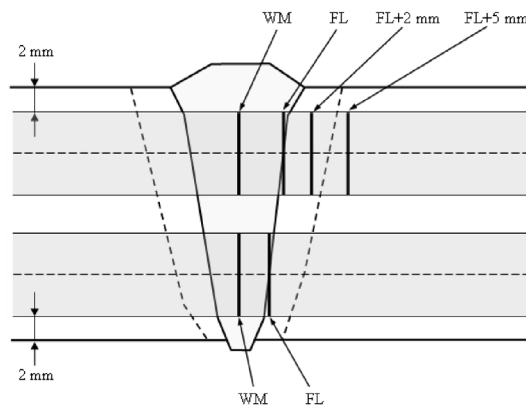

Figure 2
Longitudinal root bend test specimens



- The “FL” specimen shall sample 50% WM and 50% HAZ
- The “FL+5 mm” sample is applicable to WPQT only.

Figure 3
Charpy V-notch impact testing specimen positions for single sided welds with $t \leq 25$ mm



- The “FL” specimen shall sample 50% WM and 50% HAZ
- The “FL+ 5 mm” sample is applicable to WPQT only.

Figure 4
Charpy V-notch impact test specimen positions for single sided welds with $t > 25$ mm

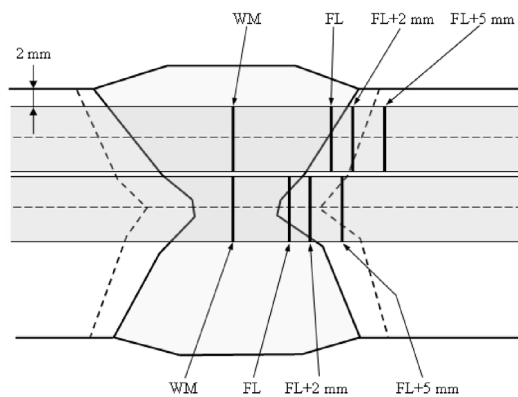

- The specimens indicated in the root area are only applicable when $t > 25$ mm)
- The “FL” specimen shall sample 50% WM and 50% HAZ
- The “FL+5 mm” samples are applicable to WPQT only (not at pipe mill).

Figure 5
Charpy V-notch impact test specimen positions for double sided welds

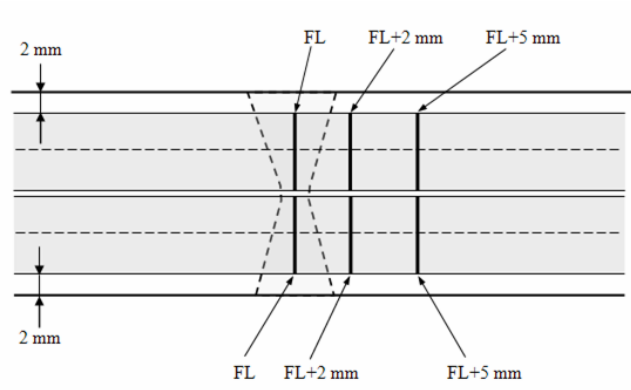

— The specimens indicated in the root area are only applicable when $t > 25$ mm).

Figure 6
Charpy V-notch impact test specimen positions for HF welds

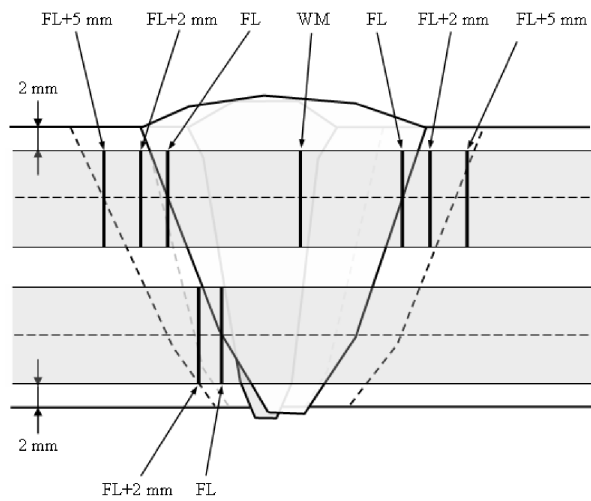

- The “FL” specimen shall sample 50% WM and 50% HAZ
- The “FL+5 mm” sample is applicable to WPQT only.

Figure 7
Charpy V-notch impact test specimen positions for full thickness repair welding of narrow gap welds

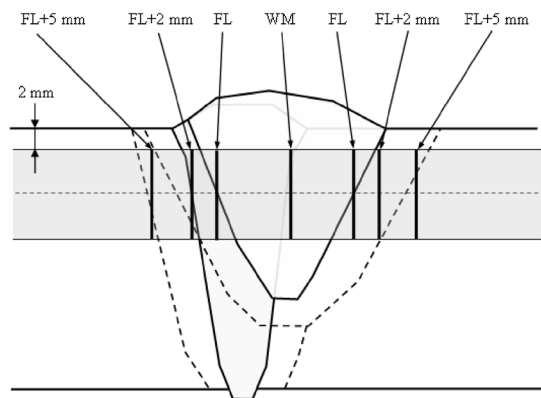

- The “FL” specimen shall sample 50% WM and 50% HAZ
- The “FL+5 mm” sample is applicable to WPQT only.

Figure 8
Charpy V-notch impact test specimen positions for partial thickness repair welding

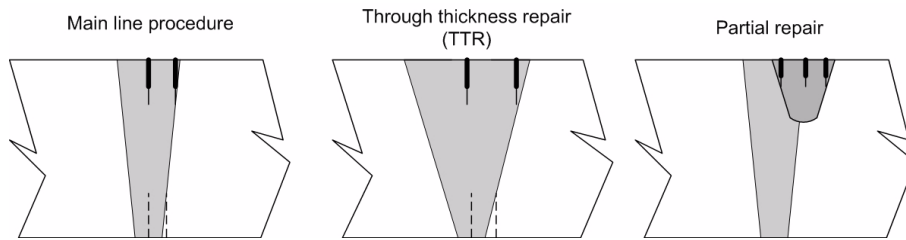

Figure 9
 Illustration of typical notch positions for fracture toughness testing of girth welds

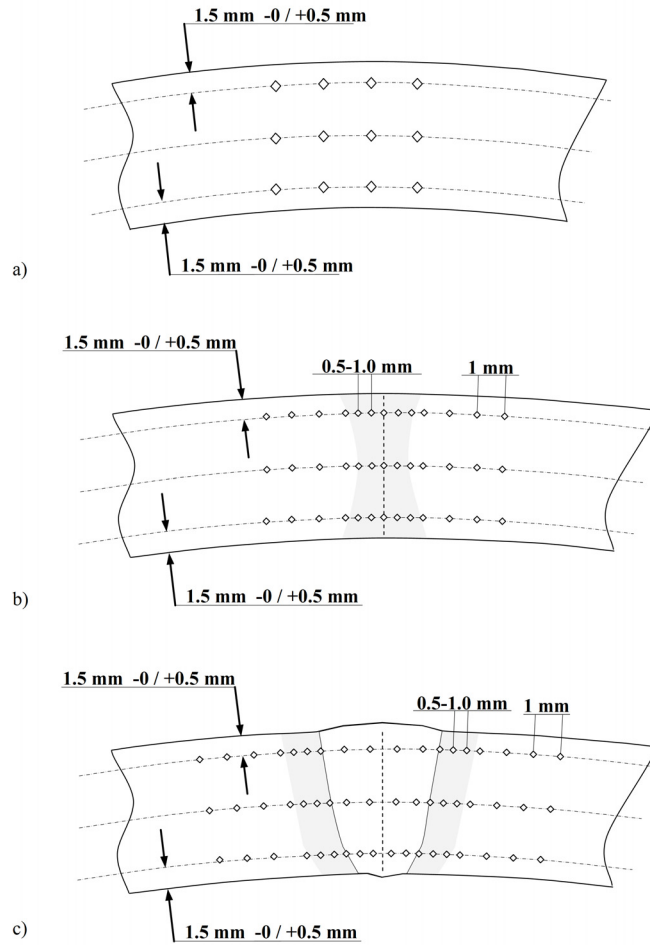

Figure 10
 Hardness locations in a) seamless pipes, b) HFW pipe, and c) fusion welded joints.

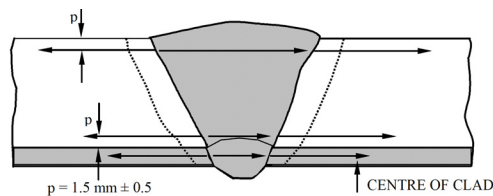

Figure 11
 Hardness locations clad materials

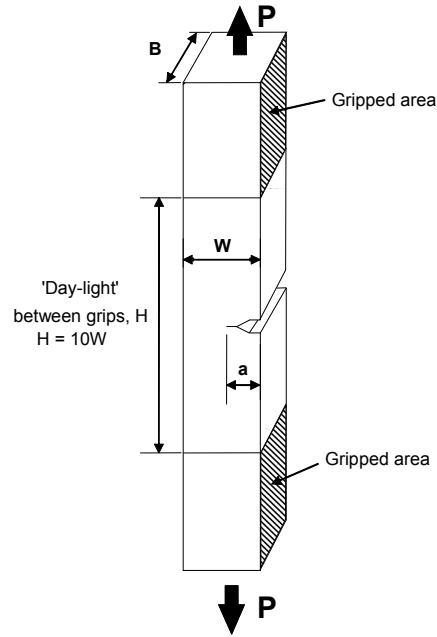

Figure 12
The clamped SENT (Single Edge Notched Tension) specimen

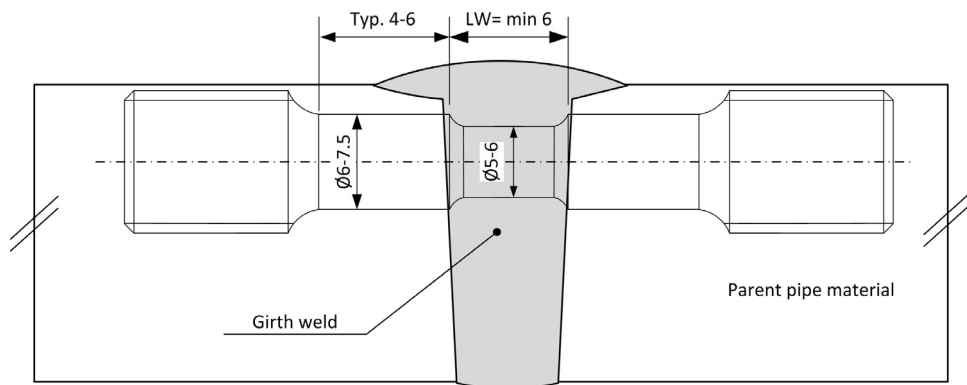

Figure 13
Tensile specimen for determination of stress/strain curves of weld metals in the weld transverse direction

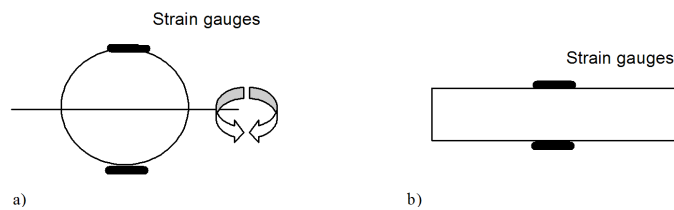

Figure 14
Instrumentation of pipe section of samples for pre-straining of materials

APPENDIX C WELDING

A. General

A 100 Objective

101 This Appendix gives requirements to all welding on submarine pipeline systems with exception of longitudinal seam welding in pipe mills that is given in Sec.7.

A 200 Application

201 This appendix applies to all fabrication involving shop-, site- or field welding including post weld heat treatment.

202 The base materials covered by this appendix are:

- C-Mn and low alloy steels
- corrosion resistant alloys (CRA) including ferritic austenitic (duplex) steel, austenitic stainless steels, martensitic stainless steels (13Cr), other stainless steels and nickel based alloys
- clad and lined steels.

The base material requirements are specified in Sec.7 and Sec.8.

203 Welding may be performed with the following processes unless otherwise specified:

- Shielded Metal Arc Welding, SMAW (Process ISO 4063-111)
- Flux Cored Arc Welding with active gas shield, G-FCAW (Process ISO 4063-136)
- Flux Cored Arc Welding with inert gas shield, G-FCAW (Process ISO 4063-137)
- Gas Metal Arc Welding with inert gas shield, GMAW (Process ISO 4063-131)
- Gas Metal Arc Welding with active gas shield, GMAW (Process ISO 4063-135)
- Tungsten Inert Gas Arc Welding, GTAW (Process ISO 4063-141)
- Submerged Arc Welding, SAW (Process ISO 4063-12)
- Plasma arc welding, PAW (Process ISO 4063-15) may be used for specific applications.

Guidance note:

GMAW and FCAW (downhill only) are regarded as methods with high potential for non-fusing type defects.

---e-n-d---of---G-u-i-d-a-n-c-e---n-o-t-e---

204 The following processes may be used for specific applications subject to agreement:

- Laser beam welding, LBW (Process ISO 4063-52)
- Electron beam welding, EBW (Process ISO 4063-51)
- Electro slag welding
- Plasma transferred arc welding, PTA.

205 Mechanised and automatic welding systems where previous experience is limited, or where the system will be used under new conditions, shall be subject to a more extensive pre-qualification programme or documentation before they may be used. The extent and the contents of a pre-qualification programme for such mechanised welding systems shall be agreed before start up. The Contractor shall prove and document that the welding systems are reliable and that the process can be continuously monitored and controlled.

A 300 Definitions

301 The following definitions are used in this appendix:

<i>Welder:</i>	Person who performs the welding.
<i>Manual welder:</i>	Welder who holds and manipulates the electrode holder, welding gun, torch or blowpipe by hand.
<i>Welding operator:</i>	Welder who operates welding equipment with partly mechanised relative movement between the electrode holder, welding gun, torch or blowpipe and the work piece.
<i>Manual welding:</i>	Welding where the welding parameters and torch guidance are controlled by the welder.
<i>Partly-mechanised welding:</i>	Welding where the welding parameters and torch guidance are controlled by the welder, but where the equipment incorporates wire feeding.

<i>Mechanised welding:</i>	Welding where the welding parameters and torch guidance are fully controlled mechanically or electronically but where minor manual adjustments can be performed during welding to maintain the required welding conditions.
<i>Automatic welding:</i>	Welding where the welding parameters and torch guidance are fully controlled mechanically or electronically and where manual adjustment of welding variables during welding is not possible and where the task of the welding operator is limited to preset, start and stop the welding operation.

A 400 Quality assurance

401 Requirements for quality assurance are given in Sec.2 B500.

B. Welding Equipment, Tools and Personnel

B 100 Welding equipment and tools

101 Inspection of the workshop, site or vessel prior to start of welding shall be required. This shall include verification of calibration and testing of all tools and welding equipment used during qualification/production welding.

Guidance note:

ISO 3834-2 gives quality requirements for welding both in workshops, sites or vessels that may be applicable for submarine pipeline systems.

---e-n-d---of---G-u-i-d-a-n-c-e---n-o-t-e---

102 Welding equipment shall be of a capacity and type suitable for the work. The equipment shall be calibrated and maintained in good working condition.

103 The control software for mechanised and automatic welding systems shall be documented. The name and unique version number of control software and the executable programme in use shall be clearly visible, e.g. on displays and/or printouts. For mechanized welding, a welding system which displays the instantaneous heat input on screen with outputs for recording various parameters should be used.

104 All welding equipment shall have a unique marking for identification.

105 Calibration status and the validity of welding, monitoring and inspection equipment shall be summarised giving reference to the type of equipment, calibration certificate and expiry date.

106 Welding return cables shall have sufficient cross section area to prevent concentration of current and shall be securely attached to prevent arc burns.

B 200 Personnel

201 All personnel involved in welding related tasks shall have adequate qualifications and understanding of welding technology. The qualification level shall reflect the tasks and responsibilities of each person in order to obtain the specified quality level.

Welding co-ordinator

202 The organisation responsible for welding shall nominate at least one authorised welding co-ordinator in accordance with ISO 14731 to be present at the location where welding is performed. The welding co-ordinator shall have comprehensive technical knowledge according to ISO 14731, paragraph 6.2.a.

Welding operators and welders

203 Through training and practise prior to qualification testing, the welding personnel shall have an understanding of (see Annex D of ISO 9606-1):

- fundamental welding techniques
- welding procedure specifications
- relevant methods for non-destructive testing
- acceptance criteria.

204 Welding operators performing automatic welding shall be qualified according to EN 1418 or ISO14732.

205 Welders performing manual, partly-mechanised welding and mechanised welding shall be qualified for single side butt welds of pipes or plates in the required principal position in accordance with ISO 9606-1, EN 287-1 or other relevant and recognised standards, for the respective positions, material grades and welding processes. These requirements are also applicable for welders performing temporary welds and tack welds.

206 Welders shall be qualified for single side butt welding of pipes in the required principal position. Welders may be qualified for part of the weld, root, fillers or cap by agreement. Repair welders will be qualified for all

types of repair after successfully being tested on full penetration repair providing the welding processes are the same for the particular section. Minimum repair length shall be 300 mm, and the repair shall be performed in the most difficult position expected (normally 6 o'clock position).

207 The qualification test shall be carried out with the same or equivalent equipment to be used during production welding, and should be at the actual premises, i.e. work shop, yard, and vessel. Use of other premises shall be specially agreed.

208 Qualification NDT shall be 100% visual examination, 100% radiographic or ultrasonic testing, and 100% magnetic particle or liquid penetrant testing. Test requirements and acceptance criteria shall be in accordance with Appendix D, subsection B.

209 When using processes which have high potential for non-fusing type defects, including G-FCAW (Process ISO 4063-137), bend testing shall be performed with the number of bend tests according to ISO 9606-1. Bend testing may be omitted in situations where AUT is applied during welder qualification.

210 A welder or welding operator who has produced a complete and acceptable welding procedure qualification is thereby qualified.

Retesting

211 A welder may produce additional test pieces if it is demonstrated that the failure of a test piece is due to metallurgical or other causes outside the control of the welder/welding operator.

212 If it is determined that the failure of a test is due to welder's lack of skill, retesting shall only be performed after the welder has received further training.

Period of validity

213 The period of validity of a welder qualification shall be in accordance with the standard used for qualification. A qualification can be cancelled if the welder/welding operator show inadequate skill, knowledge and performance.

214 When a qualification testing of recent date is transferred to a new project, the welding personnel shall be informed about particular project requirements for which their welding performance will be especially important.

Identification of welders

215 Each qualified welder shall be assigned an identifying number, letter or symbol to identify the work of that welder.

216 Qualified welders shall be issued with and be carrying an ID card displaying the identifying number, letter or symbol.

217 The Welding Coordinator shall maintain a list of welders ID stating the qualification range for each welder.

Thermal cutters and air-arc gougers

218 Personnel to perform air-arc gouging shall be trained and experienced with the actual equipment. Qualification testing may be required.

Operators for pin brazing and aluminothermic welding

219 Operators that have performed a qualified procedure test are thereby qualified.

220 Other operators shall each complete three test pieces made in accordance with the procedure specification prior to carrying out operation work. Each test piece shall pass the test for electrical resistance and mechanical strength according to Table C-6.

B 300 Qualification and testing of welding personnel for hyperbaric dry welding

301 Requirements for qualification and testing of welding personnel for hyperbaric dry welding are given in subsection I.

C. Welding Consumables

C 100 General

101 Welding consumables shall be suitable for their intended application, giving a weld with the required properties and corrosion resistance in the finally installed condition.

102 Welding consumables for arc welding shall be classified according to recognised classification schemes.

103 Welding consumables and welding processes shall give a diffusible hydrogen content of maximum 5 ml/100g weld metal unless other requirements are given for specific applications in this Appendix. Hydrogen testing shall be performed in accordance with ISO 3690.

104 For the FCAW welding processes it shall be documented that the hydrogen content of the deposited weld

metal will be below 5 ml diffusible hydrogen per 100 g weld metal under conditions that realistically can be expected for production welding.

105 Welding consumables for processes other than manual or mechanised arc welding may require special consideration with respect to certification, handling and storage.

106 Depletion of alloying elements during welding performed with shielding gases other than 99.99% argon shall be considered.

107 All welding consumables shall be individually marked and supplied with an inspection certificate type 3.1 according to EN 10204 or equivalent. Certificate type 2.2 is sufficient for SAW flux.

Cellulose coated electrodes

108 Cellulose coated electrodes may be used only subject to agreement for welding of pipeline girth welds in C-Mn linepipe with SMYS \leq 450 MPa. If used, the delay between completion of the root pass and the deposition of the hot pass shall be simulated during welding procedure qualification according to E108.

109 Use of cellulose coated electrodes is not permitted for:

- repair welding of pipeline girth welds
- welding of pipeline girth welds in C-Mn linepipe with SMYS $>$ 450 MPa.

Data Sheet

110 Each batch of welding consumables shall be delivered in accordance with a Manufacturer's data sheet, which shall state:

- guaranteed maximum value for diffusible hydrogen in the deposited weld metal
- the guaranteed minimum and maximum levels of C, alloying elements and any other intentionally added elements
- guaranteed mechanical properties (tensile and impact)
- determined under defined reference conditions. The data sheet shall, when relevant, also give recommendations for handling/recycling of the welding consumables in order to meet the guaranteed maximum value for diffusible hydrogen in the deposited weld metal.

Guidance note:

The Contractor responsible for the welding and the welding consumable manufacturer should agree on the content and the specified limits in the data sheets.

---e-n-d---of---G-u-i-d-a-n-c-e---n-o-t-e---

C 200 Chemical composition

201 All welding consumables shall be delivered in accordance with Manufacturer's data sheets, which shall state the minimum and maximum levels of C, Mn, Si, P, S, micro-alloying elements and any other intentionally added elements.

202 For solid wire and metal powders, the chemical analysis shall represent the product itself. The analysis shall include all elements specified in the relevant classification standard and the relevant data sheet.

203 For coated electrodes and cored wires, the analysis shall represent the weld metal, deposited according to EN 26847 (ISO 6847). The analysis shall include all elements specified in the relevant classification standard and the relevant data sheet

204 When H₂S service is specified, the chemical composition of the deposited weld metal shall comply with ISO 15156. The Ni-content in welding consumables for girth welds in C-Mn steel may be increased up to 2% Ni, provided that other requirements in ISO 15156 are fulfilled, and that the welding procedure has been tested for resistance to SSC.

205 The chemical composition of the weld overlay materials shall comply with the material requirements specified for the applicable type of overlay material or with a project specification.

C 300 Mechanical properties

Pipeline girth welds

301 Weld metal in pipeline girth welds shall, as a minimum have strength, ductility and toughness meeting the requirements of the base material.

302 For girth welds exposed to strain $\epsilon_{1,nom} < 0.4\%$, the yield stress ($R_{t0.5}$) of the weld metal should be minimum 80 MPa above SMYS of the base material. If two grades are joined, the requirement applies to the SMYS of the lower strength base material.

303 For girth welds exposed to strain $\epsilon_{1,nom} \geq 0.4\%$, the actual all weld metal yield strength measured during welding qualification shall not be more than 20 MPa below the specified maximum yield strength of the base material. ECA shall be conducted for all girth welds exposed to a strain $\epsilon_{1,nom} \geq 0.4\%$ (see Appendix A).

304 Whenever an ECA is performed, the tensile properties of the weld metal shall at least be equal to the

properties used as input to the ECA. If the properties of the weld metal do not meet these requirements, it shall be validated that the assumptions made during design and/or the ECA have not been jeopardised.

305 Whenever an ECA is performed and for steels with SMYS ≥ 450 MPa, any batch intended for use in production welding that was not qualified during welding procedure qualification, shall be qualified according to C400.

306 For girth welds, all batches of consumables used in production including possible wire / flux combinations should be qualified by testing during welding procedure qualification.

307 Batch testing is not required for steels with SMYS < 450 MPa and when ECA is not performed providing the tensile and impact properties stated on the material/supplier certificates are above 90% of the values on the material/supplier certificates for the batch used during welding procedure qualification.

Pipeline components

308 For welds in pipeline components the weld metal shall, as a minimum, have ductility and toughness meeting the requirements of the base material and the actual yield stress (Rt0.5) of the deposited weld metal should be minimum 80 MPa above SMYS of the base material. If two grades are joined, the requirement applies to the SMYS of the lower strength base material.

C 400 Batch testing of welding consumables for pipeline girth welds

401 A consumable batch is defined as the volume of product identified by the supplier under one unique batch/lot number, manufactured in one continuous run from batch/lot controlled raw materials. For solid wire welding consumables, a batch may be defined as originating from the same heat of controlled raw materials, and not necessarily manufactured in one continuous run.

402 Batch testing shall be conducted to verify that consumables not tested during qualification of the welding procedure will give a deposited weld metal nominally equivalent to those batches used for welding procedure qualification, with respect to chemistry and mechanical properties.

403 The batch testing shall be performed for all welding consumables, including possible wire/flux combinations. Consumable batches and combinations used during WPQ are considered tested.

404 Each individual product (brand name and dimensions) shall be tested once per batch/lot, except for solid wire originating from the same heat, where one diameter may represent all. SAW fluxes do not require individual testing but SAW wires shall be tested in combination with a selected, nominal batch of flux of the same classification as used for the welding of the girth welds.

Mechanical testing

405 The testing shall be performed on samples taken from girth welds welded according to the welding procedure to be used in production. Samples shall be removed from the 12 and 6 o'clock positions and from the 3 or 9 o'clock positions. The testing at each position shall be performed as required in Appendix B, and include:

- 1 transverse all weld metal tensile test.
- 1 macro section taken adjacent to the all-weld metal tensile test. The macro section shall be hardness tested (HV10) vertically through the weld centre line with indentations spaced 1.5 mm apart
- 1 set of Charpy V-notch test at weld centre line in the same locations as tested during WPQT. Test temperature shall be the same as for qualification of the relevant welding procedure.

406 If an ECA is not performed, the mechanical properties shall meet the specified minimum requirements.

407 If an ECA is used as basis for establishing acceptance criteria for pipeline girth welds (see Appendix A), fracture toughness testing shall be performed with the same type of specimens and test conditions as for qualification of the relevant welding procedure, whenever:

- average impact test values are not within 80% of the average value obtained during WPQT
- the transverse all weld metal yield stress is not within 90% of the value obtained during WPQT

In case of fracture toughness testing, the results shall as a minimum meet the values that have been used as the basis for the ECA.

Chemical analysis

408 For solid wire and metal powders the analysis shall represent the product itself. For coated electrodes and cored wires, the analysis shall represent the weld metal, deposited according to EN 26847 (ISO 6847). The analysis, made by manufacturer or contractor, shall include:

- all elements specified in the relevant classification standard and the relevant data sheet, see C201
- the N content.

409 The chemical analysis shall be in accordance with the composition ranges stated in the Manufacturer's data sheets, see C201.

C 500 Shielding, backing and plasma gases

501 The classification and designation and purity of shielding, backing and plasma gases shall be in compliance with ISO 14175.

502 Gases shall be delivered with a certificate stating the classification, designation, purity and dewpoint of the delivered gas.

503 The gas supply/distribution system shall be designed and maintained such that the purity and dewpoint is maintained up to the point of use.

504 Shielding, backing and plasma gases shall be stored in the containers in which they are supplied. Gases shall not be intermixed in their containers.

505 If gas mixing unit systems are used, the delivered gas composition shall be verified and regularly checked.

C 600 Handling and storage of welding consumables

601 A detailed procedure for storage, handling, recycling and re-baking of welding consumables to ensure that the hydrogen diffusible content of weld metal is maintained at less than 5 ml per 100 g weld metal shall be prepared. The procedure shall, as a minimum, be in accordance with the Manufacturer's recommendations. The procedure shall be reviewed and agreed prior to start of the production.

602 The Manufacturer's recommendations may be adapted for conditions at the location of welding provided the following requirements are met:

- solid and flux cored wire shall be treated with care in order to avoid contamination, moisture pick-up and rusting, and shall be stored under controlled dry conditions. Ranges of temperature and relative humidity for storage shall be stated.
- if vacuum packed low hydrogen SMAW welding consumables are not used, low hydrogen SMAW consumables shall be stored, baked, handled and re-baked in accordance with the Manufacturer's recommendation. Re-baking more than once should not be permitted
- flux shall be delivered in moisture proof containers/bags. The moisture proof integrity of bags shall be verified upon delivery and when retrieving bags for use. The flux shall only be taken from undamaged containers/bags directly into a hopper or storage container
- the temperature ranges for heated hoppers, holding boxes and storage containers shall be in accordance with the flux manufacturer's recommendations
- whenever recycling of flux is applied, the recycling process shall ensure a near constant ratio of new/recycled flux and the ratio of new/recycled flux shall be suitable to prevent any detrimental degradation of the flux operating characteristics, e.g. moisture pick-up, excessive build-up of fines and change of grain size balance.

D. Welding Procedures

D 100 General

101 Detailed Welding Procedure Specifications shall be prepared for all welding covered by this Appendix.

102 All welding shall be based on welding consumables, welding processes and welding techniques proven to be suitable for the type of material and type of fabrication in question.

D 200 Previously qualified welding procedures

General

201 A qualified welding procedure of a particular manufacturer is valid for welding only in workshops or sites under the operational technical and quality control of that manufacturer.

202 For welding procedures developed, qualified and kept on file for contingency situations such as hyperbaric welding procedures intended for pipeline repair and other contingency situations, the restrictions below shall not apply.

Pipeline girth welds

203 Previously qualified welding procedures shall not be used for:

- welding of girth welds when the SMYS of C-Mn linepipe is > 450 MPa
- welding of girth welds in clad or lined, duplex stainless steel or 13Cr martensitic stainless steel linepipe.

204 Except as limited by D203 above, a WPS for new production may be based on a previously qualified WPQR. The type and extent of testing and test results for the previously qualified WPQR shall meet the requirements of this Appendix. A WPS for the new production shall be specified within the essential variables of this Appendix.

205 For WPQRs older than 5 years the validity shall be documented through production tests.

Pipeline components

206 Previously qualified welding procedures shall not be used for welding of steels with SMYS > 450 MPa. A WPS for new production may otherwise be based on a previously qualified WPQR. The type and extent of testing and test results for the previously qualified WPQR shall meet the requirements of this Appendix and a WPS for the new production shall, based the previously qualified WPQR, be specified within the essential variables of this Appendix.

207 For a WPQR where the actual qualification is more than 5 years old, it shall be documented through production tests that a WPS based on the qualifying WPQR have been capable of producing welds of acceptable quality over a period of time. Alternatively a limited confirmation welding may be performed to demonstrate that the WPS is workable and producing welds of acceptable quality.

D 300 Preliminary welding procedure specification

301 A preliminary Welding Procedure Specification (pWPS) shall be prepared for each new welding procedure qualification. The pWPS shall contain the relevant information required for making a weld for the intended application when using the applicable welding processes, including tack welds.

D 400 Welding procedure qualification record

401 The Welding Procedure Qualification Record (WPQR) shall be a record of the materials, consumables, parameters and any heat treatment used during qualification welding and the subsequent non-destructive, destructive and corrosion test results. All essential variables used during qualification welding that are relevant for the final application of the WPQR shall be documented and the welding parameters recorded in relevant positions for each pass.

D 500 Welding procedure specification

501 A Welding Procedure Specification (WPS) is a specification based on one or more accepted WPQRs. One or more WPSs may be prepared based on the data of one or more WPQRs provided the essential variables are kept within the acceptable limits and other requirements of this Appendix are met. A WPS may include one or a combination of welding processes, consumables or other variables. All limits and ranges for the applicable essential variables for the welding to be performed shall be stated in the WPS.

502 The WPS shall be submitted together with the referenced supporting WPQR(s) for review and acceptance prior to start of production.

D 600 Welding procedure specification for repair welding

601 Repair welding procedure specifications shall be prepared in line with the type of repair weld qualifications required in E307.

D 700 Contents of pWPS

701 The pWPS shall contain the relevant information required for the applicable welding processes, including any tack welds. A pWPS for production welding shall include the information given in Table C-1 and D702, as relevant for the welding to be performed.

Additional requirements to pWPS for mechanised welding of pipeline girth welds

Table C-1 Contents of pWPS	
<i>Manufacturer</i>	<i>Identification of manufacturer</i>
pWPS	Identification of the pWPS
Welding process	Welding process and for multiple processes; the order of processes used Manual, partly-mechanised, mechanised and automatic welding
Welding equipment	Type and model of welding equipment. Number of wires
Base materials	Material grade(s), supply condition, chemical composition and manufacturing process. For steels with SMYS > 450 MPa; Steel supplier and For CRAs; UNS and PRE numbers.
Material thickness and diameter	Material thickness of test piece. Nominal ID of pipe
Groove configuration	Groove design/configuration; dimensions and tolerances of angles, root face, root gap and when applicable; diameters. Backing and backing material.
Alignment and tack welding	Tack welding (removal of tack welds or integration of tack welds in the weld) Type of line-up clamp. Stage for removal of line-up clamp
Welding consumables	Electrode or filler metal diameter or cross section area. Type, classification and trade name. Manufacturer consumable data sheet shall be attached.
Shielding, backing and plasma gases	Designation, classification and purity according to ISO 14175. Nominal composition of other gases and gas mixtures. Gas flow rate

Table C-1 Contents of pWPS (Continued)	
<i>Manufacturer</i>	<i>Identification of manufacturer</i>
Electrical characteristics and pulsing data	Polarity. Type of current (AC, DC or pulsed current). Pulse welding details (machine settings and/or programme selection)
Arc Characteristics	Spray arc, globular arc, pulsating arc or short circuiting arc
Welding techniques	Welding position according to ISO 6947. Welding direction. Stringer/weave beads. Sequence of deposition of different consumables. Number of passes to be completed before cooling to below preheat temperature. Accelerated weld cooling (method and medium). For double sided welding: Sequence of sides welded first and last and number of passes welded from each side. For cellulose coated electrodes: Time lapse between completion of root pass and start of hot pass and number of welders on each side.
Preheating	Method of preheat and minimum preheat temperature. Minimum initial temperature when preheat is not used.
Interpass temperature	Maximum and minimum interpass temperature
Heat input	Heat input range for each pass
Post weld heat treatment	Method, time and temperature for post heating for hydrogen release Method of post weld heat treatment (holding time and heating and cooling rates)
Specific for the SMAW welding process	Run-out length of electrode or travel speed
Specific for the SAW welding process	Number and configuration of wire electrodes. Flux, designation, manufacturer and trade name. Additional filler metal. Contact tip - work piece distance. Arc voltage range.
Specific for the FCAW welding process	Mode of metal transfer (short circuiting, spray or globular transfer)
Specific for the GMAW welding process	Shielding and backing gas flow rate. Additional filler metal. Contact tip - work piece distance. Arc voltage range.
Specific for the GTAW welding process	Shielding and backing gas flow rate. Nozzle diameter. Diameter and codification of tungsten electrode (EN ISO 6848). Hot or cold wire.
Specific for the PAW welding process	Shielding, backing and plasma gas flow rate. Nozzle diameter. Type of torch. Contact tip - work piece distance. Hot or cold wire
Specific for mechanized welding processes (general)	Control software (programme and/or software version. List of welding parameters that can be adjusted by the welders. Minimum number of welders for each pass.
Specific for mechanized GMAW welding process	Wire feed. Oscillation width and frequency. Side wall dwell time.
Specific for mechanized GTAW/PAW welding processes	Programmed arc voltage. Wire feed including pulsing pattern and timing diagram. Oscillation width and frequency. Side wall dwell time. Shielding gas timing diagrams and pulse pattern.

Additional requirements to pWPS for repair welding

702 A pWPS for repair welding shall in addition to the requirements applicable for a pWPS for production welding include the following information:

- type of repair (see Table C-7)
- method of removal of the defect, preparation and design of the repair weld excavation
- minimum repair depth and length
- minimum ligament
- visual examination and NDT to be performed of the excavated area according to Appendix D, Subsection B to confirm complete removal of defect before welding as well as visual examination and NDT of the final repaired weld.
- In cases when through thickness or partial thickness repeated repairs are permitted or agreed (see Table C-7) the location of additional Charpy V-notch tests, in addition to the tests required by Table C-4, shall be shown on sketches in the pWPS.

D 800 Essential variables for welding procedures

801 A qualified welding procedure remains valid as long as the essential variables are kept within the limits specified in Table C-2.

802 For special welding processes as stated in A202 and welding systems using these processes other essential parameters and acceptable variations need to be applied and shall be subject to agreement.

803 The limits and ranges for essential variables for a WPS shall be based on the on documented records in one or more WPQRs.

804 The essential variables given in Table C-2 shall, when applicable, be supplemented with the requirements in D805 through D814 below.

Dissimilar material joint

805 If two different materials are used in one test piece, the essential variables shall apply to each of the materials joined. A WPQR qualified for a dissimilar material joint will also qualify each material welded to itself, provided the applicable essential variables are complied with.

Multiple test pieces

806 A number of test pieces may be required for qualifying a pWPS where the size of the test piece will not allow extraction of test specimens in the correct locations according to Figure 2. In such cases the maximum heat input variation between the different test pieces shall not exceed 25% and welding with a heat input range between the low and high heat input values is allowed provided:

- hardness test specimens are taken from the test piece welded with the lowest heat input
- impact test specimens are taken from the test piece welded with the highest heat input.

807 When it is intended to qualify a pWPS with a high and low heat input in order to allow welding within this heat input range, the maximum difference between lowest and highest heat input shall not exceed 40%. In this case the intention is to qualify two procedures with a 20% difference in heat input allowing a +/-10% tolerance for each procedure. All required mechanical testing shall be performed on test pieces welded with both high and low heat input.

808 The minimum preheat or work piece temperature to be stated in the WPS shall not be below that of the test piece with the recorded highest preheat.

809 The maximum interpass temperature of any pass to be stated in the WPS shall not be higher than the recorded highest interpass temperature during qualification of the procedure. It is not allowed to boost the interpass temperature for one pass only. The maximum interpass temperature shall reflect the maximum interpass temperature that is expected during production.

Guidance note:

The all weld tensile test sample should be taken from the depth were the interpass temperature to be stated in the WPS is measured.

---e-n-d---of---G-u-i-d-a-n-c-e---n-o-t-e---

Multiple filler metals

810 When multiple filler metals are used in a test joint, the qualified thickness for each deposited filler metal shall be between 0.75 to 1.5 times the deposited thickness of that filler material during qualification. If the mechanical properties of each filler material will not be documented by the original welding procedure qualification, separate welds with each consumable should be made to allow testing of AWT and WM/FL Charpy V-notch specimens.

Number of welders

811 If welders have been working on opposite sides of a test piece, the maximum difference in heat input between the welders shall not exceed 15%. The allowable variation in heat input shall be based on the average of the heat inputs used by the welders.

Table C-2 Essential variables for welding of pipeline girth welds and component longitudinal welds		
<i>Variable</i>		<i>Changes requiring re-qualification</i>
<i>1 Manufacturer</i>		
Manufacturer	a	Any change in responsibility for operational, technical and quality control
<i>2 Welding process</i>		
The process(es) used	a	Any change
The order of processes used	b	Any change when multiple processes are used
Manual, partly-mechanised, mechanised or automatic welding	c	Any change between manual, partly-mechanised, mechanised and automatic welding
<i>3 Welding equipment</i>		
Welding	a	Any change in make, type and model for partly-mechanised, mechanised and automatic welding
Welding equipment	b	Any change in type for manual welding
Number of wires	c	Change from single wire to multiple wire system and vice versa (e.g. going from tandem/twin to single wire). This does not apply to multiple torch systems where the wires feed into separate weld pools.
<i>4 Base materials</i>		
Material grade	a	A change from a lower to a higher strength grade but not vice versa

Table C-2 Essential variables for welding of pipeline girth welds and component longitudinal welds (Continued)		
<i>Variable</i>		<i>Changes requiring re-qualification</i>
Supply condition	b	A change in the supply condition (TMCP, Q/T or normalised)
Steel supplier	c	For SMYS \geq 450 MPa; a change in base material origin (steel/plate/pipe mills) (linepipe to linepipe girth welds only – e.g. not for components)
Chemical composition	d	An increase in Pcm of more than 0.020, CE of more than 0.030 and C content of more than 0.02% for C-Mn and low alloy steel
Manufacturing process	e	A change in manufacturing process (rolled, seamless, forged, cast)
UNS numbers.	f	A change in the UNS number for CRAs
5 Material thickness and diameter		
Material thickness (t = nominal thickness of test joint.)	a	For non-H ₂ S service: — t \leq 25 mm: A change outside 0.75 t to 1.5 t — t > 25 mm: A change outside 0.75 t to 1.25 t For H ₂ S service: — A change outside the thickness interval 0.75 t to 1.25 t
Nominal ID of pipe	b	— t \leq 25 mm: A change of pipe ID outside the range 0.5 ID to ∞ — t > 25 mm: A change of pipe ID outside the range 0.5 ID to ∞
6 Groove configuration		
Groove design/configuration.	a	Any change in groove dimensions outside the tolerances specified in the agreed WPS (all dimensions shall have tolerances).
Backing and backing material.	b	Addition or deletion of backing or change of backing material (e.g. from copper to ceramic)
7 Alignment and tack welding		
Tack welding	a	Any change in removal of tack welds or integration of tack welds in the weld.
Line-up clamp	b	Omission of a line-up clamp and a change between external and internal line-up clamp.
Removal of line-up clamp	c	Any reduction in length of each section of root pass welded; the spacing of sections, number of sections and percentage of circumference welded for external line-up clamp
	d	Any change in number of completed passes and length of passes for internal line-up clamp
Internal misalignment	e	Any increase for clad and lined pipe
8 Welding consumables		
Electrode or filler metal	a	Any change of diameter or cross section area
	b	Any change of type classification and brand (brand not applicable for bare wire)
	c	Any use of a non tested welding consumables batch when batch testing is required
	d	Any use of a welding consumables batch with a reduction in tensile or impact properties of more than –10% from the batch used for WPQR when batch testing is not required
Flux	e	Any change of type, classification and brand
	f	Any increase in the ratio of recycled to new flux
9 Shielding, backing and plasma gases		
Gases according to EN 439	a	Any change in designation, classification and purity according to EN 439
Other gases and gas mixtures	b	Any change in nominal composition, purity and dew point.
Oxygen content of backing gas	c	Any increase
Shielding gas flow rate	d	For processes 131, 135 136, 137 and 141: Any change in flow rate beyond \pm 10%
10 Electrical characteristics and pulsing data		
Polarity	a	Any change in polarity
AC, DC or pulsed current	b	Any change in type of current and a change from normal to pulsed current and vice versa.
Pulse frequency range in pulsed manual welding	c	Any change in: Pulse frequency for background and peak current exceeding \pm 10% and pulse duration range exceeding \pm 10%.
11 Arc Characteristics		
Mode of metal transfer	a	A change from spray arc, globular arc or pulsating arc to short circuiting arc and vice versa
12 Welding techniques		

Table C-2 Essential variables for welding of pipeline girth welds and component longitudinal welds (Continued)		
<i>Variable</i>		<i>Changes requiring re-qualification</i>
Angle of pipe axis to the horizontal	a	A change of more than $\pm 15^\circ$ from the position welded. The L045 position qualifies for all positions provided all other essential variables are fulfilled
Welding direction	b	A change from upwards to downwards welding and vice versa
Stringer/weave	c	A change from stringer to weave of more than 3X electrode/wire diameter or vice versa
Sequence of deposition of different consumables	d	Any change in the sequence
Sequence of sides welded first and last (double sided welds)	e	Any change in the sequence
Passes welded from each side	f	Change from single to multi pass welding and vice versa.
Number of welders	g	Any decrease in number of welders for welding of root and hot pass for cellulose coated electrodes.
Time lapse between completion of root pass and start of hot pass	h	Any increase above maximum time qualified
Weld completion	i	Any reduction in the number of passes completed before cooling to below preheat temperature.
Accelerated weld cooling	j	Any change in method and medium and any increase in maximum temperature of the weld at start of cooling.
13 Preheating		
Preheat temperature	a	Any reduction.
Initial temperature when preheat is not used	b	Any reduction.
14 Interpass temperature		
Maximum and minimum interpass temperature	a	Any increase above 25°C for C-Mn and low alloy steel. Any increase for CRAs. Any reduction below the preheat temperature.
15 Heat input		
Heat input range for each pass	a	For C-Mn and low alloy steels with SMYS ≤ 450 MPa in non-H ₂ S service: Any change exceeding $\pm 15\%$
	b	For C-Mn and low alloy steels with SMYS > 450 MPa and C-Mn and low alloy steels in H ₂ S service: Any change exceeding $\pm 10\%$
	c	For CRAs: Any change exceeding $\pm 10\%$
16 Post weld heat treatment		
Post heating; hydrogen release	a	Any reduction in the time and temperature and deletion but not addition of post heating.
Post weld heat treatment	b	Addition or deletion of post weld heat treatment. Any change in holding temperature exceeding $\pm 20^\circ\text{C}$. Any change in heating and cooling rates outside $\pm 5\%$
Holding time	c	Any change in holding time outside below formula ($\pm 5\%$): $holding\ time = (actual\ thickness/qualified\ thickness) \times qualified\ holding\ time$
17 Specific for the SAW welding process		
Wire electrode configuration.	a	Each variant of process 12 (121 to 125) shall be qualified separately
Flux	b	Any change of type, classification and brand.
Arc voltage range.	c	Any change beyond $\pm 10\%$
18 Specific for the FCAW welding process		
Mode of metal transfer	a	A change from short circuiting transfer to spray or globular transfer. Qualification with spray or globular transfer qualifies both spray or globular transfer
19 Specific for the GMAW welding process		
Arc voltage range	a	Any change beyond $\pm 10\%$
20 Specific for the GTAW welding process		
Diameter and codification of tungsten electrode (ISO 6848)	a	Any change
Hot or cold wire.	b	A change from hot to cold wire and vice versa
21 Specific for the PAW welding process		
Hot or cold wire	a	A change from hot to cold wire and vice versa

Additional essential variables for mechanised and automatic welding of pipeline girth welds

812 For mechanised and automatic welding of pipeline girth welds the following additional essential variables apply:

- any change of control software
- any change of pre-set parameters (parameters that can not be adjusted by the welder) for automatic welding
- any change in programmed parameters and their variation, except that necessary variation in oscillation width for welding of thinner/ heavier wall than used during qualification shall be allowed for mechanised GMAW, GTAW and PAW.
- any change in limits for parameters that can be adjusted by the welder. (“hot-key limits”).

Essential variables for repair welding

813 For repair welding the following essential variables apply:

- the essential variables given in Table C-2
- a change from internal to external repairs and vice versa for pipeline girth welds
- a change from multi pass to single pass repairs and vice versa
- a change from cold to thermal method for removal of the defect but not vice versa
- any increase above 20% in the depth of excavation for partial thickness repairs.

Post weld heat treatment

814 If CRA or clad welds are subject to solution annealing heat treatment after welding a slight variation in welding parameters outside those in Table C-2, Items 10 through 15 may be agreed.

E. Qualification of Welding Procedures

E 100 General

101 Qualification welding shall be performed based upon the accepted pWPS, using the type of welding equipment to be used during production welding, and under conditions that are representative of the actual working environment for the work shop, site, or vessel where the production welding will be performed.

Test joints

102 The number of test joints shall be sufficient to obtain the required number of specimens from the required locations given in Figure 1 and Figure 2. Allowance for re-testing should be considered when deciding the number of test joints to be welded.

103 The test joints for qualification welding shall be of sufficient size to give realistic restraint during welding.

104 The base material selected for the qualification testing should be representative of the upper range of the specified chemical composition for C-Mn and low alloy steels, and of the nominal range of the specified chemical composition for corrosion resistant alloys.

105 The material thickness shall be the same for both pipes/components/plates to be welded, except to qualify joining of two base materials with unequal thickness and for fillet end T-joint test pieces.

Qualification welding

106 Certificates for materials and consumables, including shielding, backing and plasma gases, shall be verified, and validity and traceability to the actual materials shall be established prior to start of qualification welding. The records from qualification welding shall include all information needed to establish a WPS for the intended application within the essential variables and their allowable ranges.

107 The following requirements apply:

- the welding qualification test shall be representative for the production welding with respect to welding positions, interpass temperature, application of preheat (propane will also qualify for induction coil preheating), heat conduction, etc.
- if multiple welding arcs are combined in a single welding head the parameters for each welding arc shall be recorded.
- the direction of plate rolling (when relevant) and the 12 o'clock position (for fixed pipe positions) shall be marked on the test piece.
- when more than one welding process or filler metal is used to weld a test piece, the parameters used and the approximate thickness of the weld metal deposited shall be recorded for each welding process and filler metal.
- if tack welds are to be fused into the final joint during production welding, they shall be included when welding the test piece.
- backing gas oxygen content and the duration of backing gas application before, during and after welding shall be recorded.

- each test piece shall be uniquely identified by hard stamping or indelible marking adjacent to the weld and the records made during test welding, non-destructive testing and mechanical testing shall be traceable to each test piece.

Pipeline girth welds

- the welding qualification test shall be representative for the production welding with respect to angle of pipe axis., interpass temperature, application of preheat, heat conduction, etc.
- for girth welds in welded pipe in all positions, except 1G (PA) and 2G (PC), it is recommended that one of the pipes used for the welding procedure qualification test be fixed with the longitudinal weld in the 6 or 12 o'clock position.
- for welding of pipe with diameter $\geq 20''$ in fixed positions, the weld circumference shall be divided in appropriate sectors around the circumference. The welding parameters shall be recorded for each pass in each sector and for each welding arc. For manual welding, the heat input for a sector shall be recorded as average of all the average heat inputs for the run-out lengths in each pass in that sector.
- for welding of pipe with diameter $< 20''$ the heat input shall be recorded for each pass. For manual welding, the heat input for each pass shall be recorded as average of all the average heat inputs for the run-out lengths in each pass in the pipe circumference.
- the release of external line-up clamps shall be simulated during qualification welding. Clamps should not be released until the completed sections of the root pass covers a minimum of 50% of the circumference with even spacing. The length of each section, the spacing of the sections, the number of sections welded and the percentage of welded sections of the circumference shall be recorded.
- if it is expected that the interpass temperature will drop below preheat temperature during installation welding, this scenario shall be simulated during qualification welding. The number of passes completed before cooling to below preheat temperature shall be recorded.
- accelerated cooling of the weld shall be performed during qualification welding if accelerated weld cooling, e.g. for AUT will be performed in production. The cooling method and the weld temperature at the start of the cooling shall be recorded. A macro and hardness shall be taken at cooling start point.

Cellulose covered electrodes

108 If the use of cellulose covered electrodes has been agreed, the following additional requirements shall apply:

- preheat shall be minimum 100°C
- delay between completion of the root pass and the start of depositing the hot pass shall be minimum 6 minutes
- immediately upon completion of welding during welding procedure qualification the test pieces shall be water quenched as soon as the temperature of the test piece is below 300°C
- non destructive testing of the test piece shall be by Automated Ultrasonic Testing (AUT) or Radiographic testing and Manual Ultrasonic Testing.

E 200 Repair welding procedures

201 Repair welding shall be qualified by a separate weld repair qualification test.

202 Preheat for repair welding should be minimum 50°C above minimum specified preheat for production welding.

203 When a heat treated pipe or component is repaired by welding, a new heat treatment may have to be included in the qualification of the weld repair procedure, depending on the effect of the weld repair on the properties and microstructure of the existing weld and base material.

204 Qualification of repair welding procedures shall be made by excavating a groove in an original weld welded in accordance with a qualified welding procedure.

205 The excavated groove shall be of sufficient length to obtain the required number of test specimens + 50 mm at each end.

Repeated repairs

206 If repeated weld repairs are permitted or agreed, these shall be qualified separately.

207 In case of repeated repairs, the test piece shall contain a repair weld of a qualified repaired original weld. For repeated in-process root repair, single pass cap repair and/or single pass root sealing repairs the repair weld shall be removed prior to re-repair.

Qualification welding

208 The qualification test shall be made in a manner realistically simulating the repair situation to be qualified.

209 Qualification welding shall be performed in accordance with E101 through E108.

210 For pipeline girth welds the repair qualification welding shall be performed in the overhead through vertical positions.

211 For roll welding the length of the repair weld may be centred at the 12 o'clock location for external repairs and at the 6 o'clock location for internal repairs, in which case repair welding is qualified for repair welding in these locations only.

E 300 Qualification of girth butt welds and component longitudinal welds welding procedures

301 Qualification of welding procedures for pipeline system girth welds and welds in pipeline components may be performed by any of the arc welding processes specified in A200.

302 The WPS shall be qualified and approved by all parties prior to start of any production welding.

303 The type and number of destructive tests for welding procedure qualification are given in Table C-3, with methods and acceptance criteria as specified in Subsection F below.

304 For pipeline girth welds exposed to strain $\geq 0.4\%$, it should be required to perform testing to determine the properties of weld metal in the strained and aged condition after deformation cycles and also at elevated temperature. See Appendix A, Subsection G.

Table C-3 Qualification of welding procedures for girth butt welds including component longitudinal welds

TEST JOINT		MINIMUM NUMBER OF EACH SPECIFIED TEST									
Wall thickness (mm)	D (mm)	Transverse weld Tensile	Transverse all-weld Tensile ¹⁾	All-weld tensile ^{1), 2)}	Root bend ¹⁰⁾	Face bend ¹⁰⁾	Side bend ¹⁰⁾	Charpy V-notch sets ^{4,5,6,7)}	Macro and hardness ¹¹⁾	Other tests ¹²⁾	Fracture toughness
≤ 25	≤ 300	2	2	2	2 ³⁾	2 ³⁾	0	4 ⁸⁾	2	13)	13)
	> 300	2	2	2	4 ³⁾	4 ³⁾	0	4 ⁸⁾	2	13)	13)
> 25	≤ 300	2	2	2	0	0	4	6 ^{8,9)}	2	13)	13,14)
	> 300	2	2	2	0	0	4	6 ^{8,9)}	2	13)	13,14)

Notes:

- 1) The strength mismatch between the girth weld and the parent material shall be evaluated when ECA is required. All-weld tensile tests are recommended if an ECA is performed. However, transverse all-weld specimens are also acceptable. In case of ECA full stress-strain curves shall be established as far as possible, see also Appendix A.
- 2) All weld tensile tests are not required for $D \leq 200$ mm and not if transverse all-weld tests are performed.
- 3) For welding processes GMAW and FCAW, side bend tests shall be performed instead of root and face bend tests.
- 4) Impact testing is not required for $t < 6$ mm.
- 5) Each Charpy V-notch set consists of 3 specimens.
- 6) The notch shall be located in the weld metal, the fusion line (FL) sampling 50% of HAZ, FL+2 mm and FL+5 mm, see Appendix B, Figure 3 through Figure 5.
- 7) For double sided welds on C-Mn and low alloy steels, four additional sets of Charpy V-notch test specimens shall be sampled from the weld metal, FL (sampling 50% of HAZ), FL+2 mm and FL+5 mm in the root area, see Appendix B Figure 5.
- 8) If several welding processes or welding consumables are used, impact testing shall be carried out in the corresponding weld regions, even if the region tested cannot be considered representative for the complete weld.
- 9) When the wall thickness exceeds 25 mm for single sided welds, two additional sets of Charpy V-notch test specimens shall be sampled from the weld metal root and FL in the root area.
- 10) Bend tests on clad/lined pipes shall be performed as side bend tests. 4 side bend tests shall be performed (for all wall thicknesses).
- 11) For girth welds in welded pipe, one macro and hardness shall include an intersection between a longitudinal/girth weld.
- 12) Requirements for corrosion tests, chemical analysis and microstructure examination are specified in F.
- 13) Fracture toughness testing is only required when a generic or full ECA is performed for pipeline girth butt welds. Extent of testing shall be in accordance with Appendix A.
- 14) For nominal wall thickness above 50 mm in C-Mn and low alloy steels fracture toughness testing is required unless PWHT is performed.

Qualification of repair welding procedures

305 Qualification of repair welding procedures for pipeline system girth welds and welds in pipeline components may be performed by any of the arc welding processes specified in A200.

306 The WPS for repair welding shall be qualified prior to start of any production welding.

307 The following types of repairs shall be qualified to the extent that such repairs are applicable and for pipe, also if the type of repair is feasible for the size of pipe in question:

- through thickness repair
- partial thickness repair
- in-process root repair
- single pass cap repair
- single pass root sealing repair.

308 The type and number of destructive tests for qualification or repair welding procedure are given in Table C-4, with methods and acceptance criteria as specified in Subsection F below.

Repeated repairs

309 If it has been agreed to permit through thickness or partial thickness repeated repairs (see Table C-7), and a HAZ is introduced in the weld metal from the first repair, then additional Charpy V-notch sets (in addition to the tests required by Table C-4) shall be located in the re-repair weld metal and in FL, FL+2 mm and FL+5 mm of the weld metal from the first repair and/or the base material as applicable and as shown in the accepted pWPS, see D702.

310 If it has been agreed to permit repeated in-process root repair, single pass cap repair and/or single pass root sealing repair, see Table C-7, the extent of testing shall be as tests required by Table C-4.

Table C-4 Qualification of repair welding procedures for girth butt welds including components longitudinal welds

TEST JOINT <i>Type of repair)</i>	MINIMUM NUMBER OF EACH SPECIFIED TEST									
	<i>Transverse weld Tensile</i>	<i>Transverse all-weld Tensile¹⁾</i>	<i>All-weld Tensile^{1), 2)}</i>	<i>Root Bend</i>	<i>Face Bend</i>	<i>Side bend</i>	<i>Charpy V-notch sets</i>	<i>Macro and hardness</i>	<i>Other tests</i>	<i>Fracture toughness</i>
Through thickness repair	1	1	1	1 ³⁾	1 ³⁾	2 ⁴⁾	5, 6, 7)	1	8)	9,10)
Partial thickness repair	1	1	1	1 ³⁾	1 ³⁾	2 ⁴⁾	5)	1	8)	9, 10)
In-process root repair				1				1	8)	
Single pass cap repair					1			1	8)	
Single pass root sealing repair				1				1	8)	

Notes:

- 1) The strength mismatch between the girth weld and the parent material shall be evaluated when ECA is required. All-weld tensile tests are recommended if an ECA is performed. However, transverse all-weld specimens are also acceptable. In case of ECA full stress-strain curves shall be established as far as possible, see also Appendix A.
- 2) All weld tensile tests are not required for $D \leq 200$ mm and not if transverse all-weld tests are performed.
- 3) 1 root and 1 face bend test for $t \leq 25$ mm
- 4) For welding processes GMAW and FCAW, for clad/lined pipes and for all pipes when $t > 25$ mm, side bend tests shall be performed instead of root and face bend tests.
- 5) For partial penetration and through thickness repairs where a new HAZ is introduced in the original weld metal, Charpy V-notch sets of 3 specimens shall be located according to Appendix B, Figures 7 and 8.
- 6) The notch shall be located in the repair weld metal, the fusion line (FL) sampling 50% of HAZ, FL+2 mm and FL+5 mm of the base material.
- 7) If several welding processes or welding consumables are used, impact testing shall be carried out in the corresponding weld regions, even if the region tested cannot be considered representative for the complete weld.
- 8) Requirements for corrosion tests, chemical analysis and microstructure examination are specified in Subsection F.
- 9) Fracture toughness testing of repairs is only required when a generic or full ECA is performed for the original pipeline girth butt welds. Extent of testing shall be in accordance with Appendix A.
- 10) For nominal wall thickness above 50 mm in C-Mn and low alloy steels fracture toughness testing is required unless PWHT is performed

E 400 Qualification of welding procedures for corrosion resistant overlay welding

Qualification of welding procedures

401 Qualification of welding procedures for corrosion resistant overlay welding shall be performed with GMAW or pulsed GTAW. Other methods may be used subject to agreement.

402 The chemical composition of test pieces shall be representative for the production conditions.

403 Qualification of weld overlay shall be performed on a test sample which is representative for the size and thickness of the production base material. The minimum weld overlay thickness used for the production welding shall be used for the welding procedure qualification test.

404 The dimensions of, or the number of test pieces shall be sufficient to obtain all required tests.

405 The test pieces used shall be relevant for the intended application of the weld overlay:

- forging or casting for overlay welding of ring grooves
- pipe with the overlay welding performed externally or internally, or
- plate or pipe with a prepared welding groove for qualification of buttering and when the weld overlay strength is utilised in the design.

406 If a buffer layer will be used in production welding, it shall also be used in welding the test piece.

407 The WPS shall be qualified prior to start of any production welding.

408 The type and number of destructive tests for welding procedure qualification are given in Table C-5 with methods and acceptance criteria specified in Subsection F below.

Table C-5 Qualification of corrosion resistant overlay welding procedures						
<i>TEST JOINT</i>	<i>MINIMUM NUMBER OF EACH SPECIFIED TEST</i>					
<i>Thickness of base material</i>	<i>Side bend</i>	<i>Macro and hardness tests</i>	<i>Chemical Analysis</i>	<i>All-weld Tensile</i>	<i>Charpy V-notch Impact tests</i>	<i>Other tests</i>
All	4 ¹⁾	1	1	2 ²⁾	2,3,4,5)	6)
Notes:						
1) Side bend specimens shall be taken transverse to the welding direction.						
2) Only required when the weld overlay strength is utilised in the design of the welded joint (e.g. load bearing weld overlay).						
3) Only required when the weld overlay is load bearing across the overlay/base material fusion line.						
4) Sets shall be tested with the notch in the overlay weld metal, FL, and FL+2 mm and FL+5 mm in the base material.						
5) If several welding processes or welding consumables are used, impact testing shall be carried out in the corresponding weld regions if the region otherwise required to be tested cannot be considered representative for the complete weld.						
6) Requirements for corrosion tests and microstructure examination are specified in subsection F.						

Qualification of repair welding procedures

409 Unless the production welding procedure can be applied, the repair welding procedure shall be qualified. Weld repair performed on weld overlay machined to the final thickness shall be separately qualified.

410 The type and number of destructive tests for qualification of repair welding procedure are given in Table C-5. In cases when qualification is performed using a pipe, component or plate with a prepared welding groove, and a new HAZ is introduced in the original weld metal, additional Charpy V-notch impact sets shall be located according to Appendix B, Figure 7 and Figure 8.

E 500 Qualification of procedures for Pin Brazing and Aluminothermic welding of anode leads

Qualification of procedures

501 Attachment of anode leads shall be by pin brazing or aluminothermic welding methods. Other methods may be used subject to agreement. Full details of the technique used and associated equipment shall be available prior to qualification of procedures.

502 The chemical composition of test pieces shall be representative for the production conditions and be selected in the upper range of the chemical composition.

503 Qualification for brazing/welding of anode leads shall be performed on test samples which is representative for the size and thickness of the production base material and the number of test pieces shall be minimum 4 and sufficient to obtain all required tests.

504 The WPS shall be qualified prior to start of any production.

Table C-6 Qualification of Pin Brazing and Aluminothermic welding procedures					
<i>TEST JOINT</i>	<i>MINIMUM NUMBER OF EACH SPECIFIED TEST ¹⁾</i>				
<i>Thickness of base material</i>	<i>Electrical resistance</i>	<i>Mechanical strength</i>	<i>Copper penetration ²⁾</i>	<i>Hardness ³⁾</i>	<i>Pull test</i>
All	4	4	4	4	4
Notes					
1) The number of tests refers to the total number of tests from all pieces.					
2) 2 test specimens shall be sectioned transverse to the anode lead and 2 test specimens parallel with the anode lead.					
3) The hardness tests shall be made on the specimens for copper penetration measurements.					

505 The type and number of destructive tests for procedure qualification are given in Table C-6 with methods and acceptance criteria specified in Subsection F below.

E 600 Qualification of welding procedures for temporary and permanent attachments and branch welding fittings to linepipe

Qualification of welding procedures

601 Qualification of welding procedures for temporary and permanent attachments and branch welding fittings to linepipe may be performed by any of the arc welding processes specified in A200, but use of cellulose coated electrodes is not permitted.

602 The WPS shall be qualified prior to start of any production welding.

603 The type and number of destructive tests for welding procedure qualification are given in E604 to E614 with methods and acceptance criteria as specified in Subsection F.

Longitudinal welds in doubler sleeves

604 Longitudinal welds in doubler sleeves shall be made with backing strips and qualified as required in E300 and Table C-3, but with the extent of testing limited to:

- transverse weld tensile
- Charpy V-notch impact testing
- macro and hardness testing,

Fillet welds in doubler sleeves and anode pads

605 The fillet weld qualification test shall comprise two test pieces welded in the PD and PF plate positions to qualify the welding procedure for welding in all positions.

606 The extent of testing for each test piece shall be 3 macro and hardness specimens taken from the start, end and middle of each test weld with methods and acceptance criteria as specified in Subsection F.

Branch welding fittings

607 The branch fitting qualification test welds shall be welded in the PF and PD pipe positions to qualify welding in all positions.

608 The extent of testing shall be 4 macro and hardness specimens taken from the 12, 3, 6 and 9 o'clock locations of each test weld. A procedure qualified as a butt weld may be used.

609 Charpy V-notch impact testing with the notch in the weld metal, FL, FL+2 mm and FL+5 mm using full size or reduced size specimens shall always be performed whenever the material thickness allows. Charpy V-notch specimens shall be taken from both test welds.

Qualification of repair welding procedures for longitudinal welds in doubler sleeves

610 Repair welding procedures for longitudinal welds in doubler sleeves shall be qualified as required in E300 and Table C-4, but with the extent of testing modified according to E604.

Qualification of repair welding procedures for fillet welds

611 Qualification welding shall be performed in the PD and PF plate positions. The extent of qualification of repair welding procedures shall at as a minimum consist of:

- through thickness repair
- single pass repair against the pipe material
- single pass repair against the sleeve material.

612 Methods of testing and acceptance criteria shall be as specified in Subsection F.

Qualification of repair welding procedures for branch welding fittings

613 Qualification welding shall be performed in the PD and PF pipe positions. The extent of qualification of repair welding procedures shall at as a minimum consist of:

- through thickness repair
- single pass cap repair against the fitting
- single pass cap repair against the pipe.

614 Methods of testing and acceptance criteria shall be as specified in Subsection F.

E 700 Qualification of welding procedures for structural components

701 Welding procedures for structural components, supplied as a part of the pipeline systems, shall be qualified in accordance with ISO 15614-1. The requirements shall be appropriate for the structural categorisation of the members and stresses in the structure. The extent of tensile, hardness and impact testing and the testing conditions should be in compliance with this Appendix.

E 800 Qualification of welding procedures for hyperbaric dry welding

801 Requirements for qualification of welding procedures for hyperbaric dry welding are given in Subsection I.

F. Examination and Testing for Welding Procedure Qualification

F 100 General

101 All visual examination, non-destructive testing, mechanical testing and corrosion testing of test pieces shall be performed in the as welded or post weld heat treated condition, whatever is applicable for the final product.

Visual examination and non-destructive testing

102 Visual examination and non-destructive testing shall be performed no earlier than 24 hours after the

completion of welding of each test piece. Original welds intended for repair welding qualification may be examined and tested when temperature of test piece allows for it.

103 If a test piece does not meet the acceptance criteria for visual examination and NDT, one further test piece shall be welded and subjected to the same examination. If this additional test piece does not meet the requirements, the WPQ is not acceptable.

Destructive testing

104 The type and number of mechanical tests and microstructure evaluations for qualification tests are given in E300 to E700.

105 Test specimens shall be taken from the positions shown in Figure 1 and Figure 2 for longitudinal welds and girth welds respectively.

Re-testing

106 A destructive test failing to meet the specified requirements may be re-tested. The reason for the failure shall be investigated and reported before any re-testing is performed. If the investigation reveals that the test results are influenced by improper sampling, machining, preparation, treatment or testing, the test sample and specimen (as relevant) shall be replaced by a correctly prepared sample or specimen and a new test performed.

107 A destructive test failing to meet the specified requirements shall be rejected if the reason for failure can not be related to improper sampling, machining, preparation, treatment or testing of specimens.

108 Re-testing of a test failing to meet the specified requirements should only be performed subject to agreement. This re-testing shall consist of at least two further test specimens/sets of test specimens. If both re-tests meet the requirements, the test may be regarded as acceptable. All test results, including the failed tests, shall be reported.

109 If there are single hardness values in the different test zones (weld metal, HAZ, base material) that do not meet the requirement, retesting shall be carried out on the reverse side of the tested specimen or after grinding and re-preparation of the tested surface. None of these additional hardness values shall exceed the maximum value.

110 For Charpy V-notch impact testing the following requirements shall apply:

- in order to consider a set as approved, the average requirement has to be met and only one test specimen out of the three may have a value between the average and the single minimum requirement.
- subject to agreement, retest may be performed with two test specimen sets. All re-tested specimens shall meet the specified minimum average toughness.

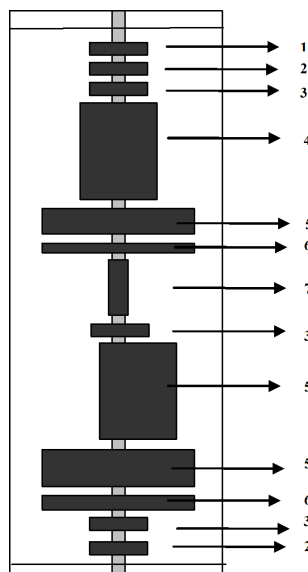
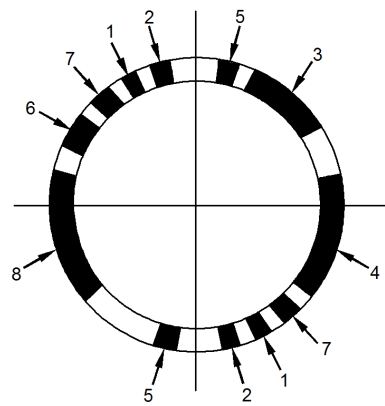

Figure 1
Welding procedure qualification test - sampling of test specimens for longitudinal butt welds.

Note: The indicated location of the test specimens are not required for qualification of welding in the PA (1G) and PC (2G) positions, where sampling positions are optional.



- 1: Cross weld tensile specimens
- 2: All weld tensile specimens
- 3: Bend test specimens
- 4: Impact test specimens
- 5: Macro and hardness test specimens
- 6: Corrosion test specimens
- 7: Micro examination and chemical analysis
- 8: Fracture toughness specimens

Figure 2
Welding procedure qualification test - sampling of test specimens for girth butt welds.

Note 1: For pipeline girth welds, if applicable, one macro and hardness specimen shall include a pipe longitudinal seam weld.

Note 2: The indicated location of the test specimens are not required for qualification of welding in the PA (1G rotated) where sampling positions are optional.

F 200 Visual examination and non-destructive testing requirements

201 Each test weld shall undergo 100% visual examination and 100% ultrasonic and 100% radiographic testing and 100% magnetic particle or liquid penetrant testing. Testing shall be in accordance with Appendix D, Subsection B.

202 Acceptance criteria for visual examination and non-destructive testing shall be in accordance with Appendix D, B900 for welds exposed to strains $< 0.4\%$. For welds exposed to strains $\geq 0.4\%$, the acceptance criteria shall be as for the production welding or according to Appendix D, B900, whichever is the more stringent.

203 Weld overlay shall be non-destructively tested according to Appendix D, C300 with acceptance criteria according to Appendix D, C600. The surface and weld thickness shall be representative for the production welding, i.e. after machining of the overlay thickness or the thickness representative for the thickness on the finished component.

F 300 Testing of butt welds

301 All testing shall be performed in accordance with Appendix B.

Transverse weld tensile testing

302 For longitudinal welds and girth welds exposed to strain $\epsilon_{1,nom} \geq 0.4\%$ the fracture shall not be located in the weld metal, while for longitudinal welds and girth welds exposed to strain $\epsilon_{1,nom} < 0.4\%$ and where no ECA is performed the fracture should not be in the weld metal. The ultimate tensile strength shall be at least equal to the SMTS for the base material. When different material grades are joined, the ultimate tensile strength of the joint shall be at least equal to the SMTS for the lower grade.

All-weld tensile testing

303 For longitudinal welds and girth welds exposed to strain $\epsilon_{1,nom} < 0.4\%$ and where no ECA is performed, the upper yield or the $R_{t0.5}$ of the deposited weld metal should be 80 MPa above SMYS of the base material and the elongation not less than 18%. If two grades are joined the requirement applies to the lower strength material.

Transverse all-weld tensile testing

304 For pipeline girth welds where generic ECA acceptance criteria (see Appendix A) are applied, the upper yield or the $R_{t0.5}$ of the deposited weld metal shall not be more than 20 MPa below the specified maximum yield strength of the base material. The elongation shall not be less than 18%. When different material grades are joined, the yield stress requirements applies to the lower grade.

305 For pipeline girth welds exposed to strain $\epsilon_{1,nom} \geq 0.4\%$ and where full ECA acceptance criteria shall be applied, the upper yield or the $R_{t0.5}$ of the deposited weld metal shall not be more than 20 MPa below the

specified maximum yield strength of the base material, or the assumptions made during design and/or the ECA. The elongation shall not be less than 18%.

Bend testing

306 The end tests shall not disclose any open defects in any direction exceeding 3 mm. Minor ductile tears less than 6 mm, originating at the specimen edge may be disregarded if not associated with obvious defects.

Charpy V-notch impact testing

307 The average and single Charpy V-notch toughness at each position shall not be less than specified for the base material in the transverse direction (KVT values). Requirement for fracture arrest properties does not apply.

- C-Mn and low alloy steels shall meet the requirements given in Sec.7 B400.
- Duplex and martensitic stainless steels shall meet the requirements given in Sec.7 C400.
- The C-Mn steel backing material in clad and lined linepipe shall meet the requirements given in Sec.7 B400.

308 When different steel grades are joined, the required impact tests shall be performed on both sides of the weld. The weld metal shall meet the less stringent energy requirement.

Macro section

309 The macro section shall be documented by photographs (magnification of at least 5×).

310 The macro section shall show a sound weld merging smoothly into the base material and meeting Quality level C of ISO 5817.

311 For girth welds in welded pipe, one macro section shall include a longitudinal weld.

Hardness testing

312 The maximum hardness in the HAZ and weld metal is:

- 325 HV10 for C-Mn and low alloy steels in non-H₂S service
- 250 HV10 for C-Mn and low alloy steels in H₂S service (for weld caps not exposed to the H₂S media, maximum hardness of 275 HV10 may be agreed for base material thickness > 9 mm) unless a higher hardness has been qualified according to Sec.6 B202 and App.B C400.
- 350 HV10 for 13Cr martensitic stainless steels
- 350 HV10 for duplex stainless steels
- 325 HV10 for clad or lined material in non-H₂S service
- 275 HV10 for anode pads.

For clad or lined materials in H₂S service special considerations are required, see ISO 15156.

313 Subject to agreement, additional hardness measurements shall be taken in the start/stop area for repair weld qualification.

314 For girth welds in welded pipe, one hardness test specimen shall include a longitudinal weld.

Corrosion testing

315 Sulphide stress cracking testing (SSC) is only required for C-Mn and low alloy steels with SMYS > 450 MPa, 13Cr martensitic stainless steels and other materials not listed for H₂S service in ISO 15156.

Acceptance criteria shall be according to ISO 15156.

316 Pitting corrosion test according to ASTM G48 is only required for 25Cr duplex stainless steel (see Sec.6 B302). The maximum weight loss shall be 4.0 g/m² when tested at 40°C for 24 hours.

Microstructure examination

317 Welds in duplex stainless steel materials, CRA materials and clad/lined materials shall be subject to microstructure examination. The material shall be essentially free from grain boundary carbides, nitrides and intermetallic phases. Essentially free implies that occasional strings of detrimental phases along the centreline of the base material is acceptable given that the phase content within one field of vision (at 400X magnification) is < 1.0% (max. 0.5% intermetallic phases).

For duplex steel the ferrite content of the weld metal and HAZ shall be within the range 35 to 65%.

The ferrite content of austenitic stainless steel weld deposit shall be within the range 5 to 13%.

Micro cracking at the fusion line is not permitted.

Chemical analysis

318 For welds in clad or lined materials, a chemical analysis shall be performed. The analysis shall be representative of the CRA composition at a point at the centreline of the root pass 0.5 mm below the surface. The chemical composition shall be within the specification limits according to the UNS number for the specified cladding/lining material or, if the weld metal is of a different composition than the cladding/liner,

within the limits of chemical composition specified for the welding consumable.

Fracture toughness testing

319 Fracture toughness testing shall be performed for both girth welds and repair welds when acceptance criteria for girth welds are established by an ECA. The extent of testing shall be in accordance with Appendix A.

320 For nominal wall thickness above 50 mm in C-Mn and low alloy steels fracture toughness testing is required unless PWHT is performed.

C-Mn and low alloy steels shall meet the requirements given in Sec.7 B415.

Duplex and martensitic stainless steels shall meet the requirements given in Sec.7 C403.

F 400 Testing of weld overlay

401 When the weld overlay is not contributing to strength (e.g. not load bearing), tensile testing and Charpy V-notch testing of the weld overlay material are not required. When the weld overlay strength is considered as a part of the design, such mechanical testing of the weld overlay material is required (see F412 to F417).

402 The base material shall retain the minimum specified mechanical properties after any post weld heat treatment. The base material properties in the post weld heat treated condition shall then be documented by additional testing and recorded as a part of the welding procedure qualification.

403 The testing in F404 through F411 shall, as a minimum, be performed when the overlay material is not considered as part of the design and when the base material has not been affected by any post weld heat treatment. When the overlay material is considered to be part of design, the testing in F412 through F417 shall be performed in addition to the testing in F404 through F411.

Bend testing of weld overlay

404 The bend testing shall be performed in accordance with Appendix B, B514. The bend tests shall disclose no defects exceeding 1.6 mm. Minor ductile tears less than 3 mm, originating at the specimen edge may be disregarded if not associated with obvious defects.

Macro examination of weld overlay

405 The macro sections shall be documented by photographs (magnification of at least 5X). The macro section shall show a sound weld merging smoothly into the base material and meeting Quality level C of ISO 5817.

Hardness testing of weld overlay

406 The maximum hardness for base material and HAZ shall not exceed the limits given in F312 above as applicable for the intended service and type of material. The maximum hardness for the overlay material should not exceed any limit given in ISO 15156 for H₂S service.

Chemical analysis of weld overlay

407 The chemical composition shall be obtained in accordance with Appendix B. Specimens for chemical analysis shall either be performed directly on the as welded or machined surface or by taking specimen or filings/chips from:

- the as welded surface
- a machined surface
- from a horizontal drilled cavity.

The location for the chemical analysis shall be considered as the minimum qualified thickness to be left after any machining of the corrosion resistant weld overlay.

408 The chemical composition of overlay shall be within the specification limits according to the UNS for the specified overlay material. The iron content of alloy UNS N06625 overlay shall be < 10%.

Microstructure examination of weld overlay

409 The surface to be used for microstructure examination shall be representative of a weld overlay thickness of 3 mm or the minimum overlay thickness specified for the finished machined component, whichever is less. Microstructure examination shall be performed after any final heat treatment.

410 Metallographic examination at a magnification of 400X of the CRA weld metal HAZ and the base material shall be performed. Micro cracking at the CRA to the C-Mn/low alloy steel interface is not permitted. The material shall be essentially free from grain boundary carbides, nitrides and inter-metallic phases in the final condition (as-welded or heat treated as applicable).

411 The ferrite content of austenitic stainless steel weld overlay deposit shall be within the range 5-13%. The ferrite content of duplex stainless steel weld overlay in the weld metal and HAZ shall be within the range 35-65%.

All-weld tensile testing of load bearing weld overlay

412 All-weld tensile testing shall be performed in accordance with Appendix B B300.

413 The yield stress and ultimate tensile strength of the weld deposit shall be at least equal to the material tensile properties used in the design.

Charpy V-notch impact testing of load bearing weld overlay

414 When the weld overlay material is designed to transfer the load across the base material/weld overlay fusion line, impact testing of the weld overlay and HAZ shall be performed (i.e. when the overlay is a part of a butt joint or acts as a transition between a corrosion resistant alloy and a C-Mn/low alloy steel).

415 Testing shall be with the notch in the overlay weld metal, FL, FL+2 mm and FL+5 mm in the base material.

416 The average and single Charpy V-notch toughness at each position shall not be less than specified for the base material. When different steel grades are joined, a series of impact tests shall be considered in the HAZ on each side of the joint. The weld metal shall meet the more stringent energy requirement.

Corrosion testing of weld overlay

417 Corrosion testing and microstructure examination of stainless steel and nickel base weld overlay materials shall be considered.

F 500 Testing of pin brazing and aluminothermic welds

Electrical resistance

501 The electrical resistance of each test weld/brazing shall not exceed 0.1 Ohm.

Mechanical strength

502 Each test weld/brazing shall be securely fixed and tested with a sharp blow from a 1.0 kg hammer. The weld/brazing shall withstand the hammer blow and remain firmly attached to the base material and show no sign of tearing or cracking.

Copper penetration

503 2 test specimens shall be sectioned transverse to the anode lead and 2 test specimens parallel with the anode lead. The fusion line of the weld/brazing shall at any point not be more than 1.0 mm below the base material surface. Intergranular copper penetration of the base material shall not at any point extend beyond 0.5 mm from the fusion line.

Hardness

504 HV10 hardness tests shall be made on each of the specimens for copper penetration measurements.

505 The maximum hardness shall not exceed the limits given in F312 as applicable for the intended service and type of material.

Pull test

506 The specimen shall break in the cable.

F 600 Testing of welds for temporary and permanent attachments and branch outlet fittings to linepipe

601 Welds shall be tested to the extent required in E600 and meet the relevant requirements given in F300 above.

G. Welding and PWHT Requirements

G 100 General

101 All welding shall be performed using the type of welding equipment and under the conditions that are representative for the working environment during procedure qualification welding.

102 Pre-qualification testing shall be performed for welding systems where the Contractor has limited previous experience, or where the system will be used under new conditions. All welding equipment shall be maintained in good condition in order to ensure the quality of the weldment.

103 All welding shall be performed under controlled conditions with adequate protection from detrimental environmental influence such as humidity, dust, draught and large temperature variations.

104 All instruments shall have valid calibration certificates and the adequacy of any control software shall be documented.

105 Welding and welding supervision shall be carried out by personnel qualified in accordance with the requirements given in B200.

G 200 Production welding, general requirements

201 All welding shall be carried out strictly in accordance with the accepted welding procedure specification and the requirements in this subsection. If any parameter is changed outside the limits of the essential variables, the welding procedure shall be re-specified and re-qualified. Essential variables and variation limits are specified in D800.

- 202** The preparation of bevel faces shall be performed by agreed methods. The final groove configuration shall be as specified in the WPS and within the tolerances in the WPS.
- 203** After cutting of pipe or plate material for new bevel preparation, a new lamination check by ultrasonic and magnetic particle/dye penetrant testing should be performed. Provided it can be demonstrated that the cut has been made inside a zone where a lamination check was performed at the plate/pipe mill, the check may be omitted. Procedures for ultrasonic and magnetic particle/dye penetrant testing and acceptance criteria shall be in accordance with Appendix D.
- 204** For welding processes using shielding, backing and plasma gases, the gas classification moisture content and dew point shall be checked prior to start of welding. Gases in damaged containers or of questionable composition, purity and dew point shall not be used. All gas supply lines shall be inspected for damage on a daily basis. All gas supply lines shall be purged before the welding is started.
- 205** The weld bevel shall be free from moisture, oil, grease, rust, carbonised material, coating etc., which may affect the weld quality.
- 206** The alignment of the abutting ends shall be adjusted to minimise misalignment. Misalignment shall not exceed the tolerances in the WPS.
- 207** The weld area shall be heated to the minimum preheat temperature specified in the WPS. Pre-heating shall also be performed whenever moisture is present or may condense in the weld area and/or when the ambient temperature or material temperature is below 5°C. Welding below 20°C should not be performed.
- 208** When pre-heating is applied prior to welding, including tack welding, the pre-heating temperature shall be measured at a distance of minimum 75 mm from the edges of the groove at the opposite side of the heating source when practically possible. If this is not possible, the adequacy of the performed measurement shall be demonstrated.
- 209** Tack welding shall only be performed if qualified during welding procedure qualification. The minimum tack weld length is 2t or 100 mm, whichever is larger. Temporary tack welds using bridging or bullets shall only be performed using materials equivalent to the base material and using a WPS based on a qualified welding procedure. All such tack welds and any spacer wedges shall be removed from the final weldment. Tack welds to be fused into the weld shall be made in the weld groove only and the ends of the tack welds shall have their ends ground and feathered and examined for cracks by an adequate NDT method. Defective tack welds shall be removed or repaired prior to production welding.
- 210** Removal of tack welds shall be by grinding and cleaning followed by examination of the ground area by visual inspection. Where temporary tack welds are removed, the bevel configuration and root gaps specified in the WPS shall be maintained for the subsequent pass and the groove visually inspected prior to resuming welding of the root pass.
- 211** The interpass temperature shall be measured at the edge of the groove immediately prior to starting the following pass. For multi torch bugs, the interpass temperature is defined as the temperature in front of the first wire on each bug.
- 212** Earth connections shall be securely attached to avoid arc burns and excessive resistance heating. Welding of earth connections to the work piece is not permitted.
- 213** The number of welders and the weld sequence shall be selected in order to cause minimum distortion of the pipeline or the components.
- 214** Start and stop points shall be distributed over a length of weld and not “stacked” in the same area.
- 215** Welding arcs shall be struck on the fusion faces only. Weld repair of base material affected by stray arcs is not permitted.
- 216** Arc burns shall be repaired by mechanical removal of affected base material followed by NDT to verify absence of cracks and ultrasonic wall thickness measurements to verify that the remaining material thickness is not below the minimum allowed.
- 217** Surface slag clusters, surface porosity and high points shall be removed by grinding and the weld visually inspected prior to deposition of the next weld pass.
- 218** After weld completion, all spatter, scales, slag, porosity, irregularities and extraneous matter on the weld and the adjacent area shall be removed. The cleaned area shall be sufficient for the subsequent NDT. Peening is not permitted.
- 219** Welding shall not be interrupted before the joint has sufficient strength to avoid plastic yielding and cracking during handling. Prior to restart after an interruption, preheating to the minimum interpass temperature of the pass in question shall be applied.
- 220** Welds shall only be left un-completed if unavoidable. Welding of fittings shall always be completed without interruption. If welding is interrupted due to production restraints, the minimum number of passes specified in the WPS shall be completed before stopping welding. If the WPS does not specify a minimum number of passes, at least 3 passes or half the thickness of the joint should be completed before the welding is interrupted. When interruption of welding is imposed by production restraints, interrupted welds shall be

wrapped in dry insulating material and allowed to cool in a slow and uniform manner. Before restarting welding of an interrupted weld, the joint shall be reheated to the interpass temperature recorded during qualification of the welding procedure.

221 Maximum root gap for fillet welds should be 2 mm. Where the root gap is > 2 mm but ≤ 5 mm, this shall be compensated by increasing the throat thickness on the fillet weld by 0.7 mm for each mm beyond 2 mm gap. Welding of fillet welds with root gap > 5 mm is subject to repair based on an agreed procedure.

G 300 Repair welding, general requirements

301 The allowable repairs and re-repairs are given in Table C-7 and are limited to one repair in the same area. Repeated repairs shall be subject to agreement and are limited to one repeated repair of a previously repaired area.

<i>Type of repair</i>	<i>Type of material</i>			
	<i>C-Mn and low alloy steel</i>	<i>13Cr MSS</i>	<i>Clad/lined</i>	<i>CRA/Duplex SS 1)</i>
Through thickness repair	Permitted	Permitted	If agreed	If agreed
Partial thickness repair	Permitted	Permitted	Permitted	Permitted
In-process root repair	Permitted	Permitted	Permitted	Permitted
Single pass cap repair	Permitted	Permitted	Permitted	Permitted
Single pass root sealing repair	If agreed	If agreed	If agreed	If agreed
Through thickness repeated repair	If agreed	Not permitted	Not permitted	Not permitted
Partial thickness repeated repair	If agreed	Not permitted	Not permitted	Not permitted
In-process root repeated repair	Not permitted	Not permitted	Not permitted	Not permitted
Single pass cap repeated repair	Not permitted	Not permitted	Not permitted	Not permitted
Single pass root sealing repeated repair	Not permitted	Not permitted	Not permitted	Not permitted
Note				
1) Provided solution annealing is performed after welding, all repairs are allowed.				

302 Repair welding procedures shall be qualified to the extent that such repairs are feasible and applicable for the repair situation in question. Qualification of repair welding procedures denoted “if agreed”, need only be done if performing such repairs is agreed and are feasible for the repair situation in question.

303 Cellulosic coated electrodes shall not be used for repair welding.

304 Repair welding of cracks is not permitted unless the cause of cracking by technical evaluation has been established not to be a systematic welding error (cracks in the weld is cause for rejection).

305 Defects in the base material shall be repaired by grinding only.

306 Defective welds that cannot be repaired with grinding only may be repaired locally by welding. Repair welding shall be performed in accordance with a qualified repair welding procedure. For welding processes applying large weld pools, e.g. multi-arc welding systems, any unintended arc-stops shall be considered as defects.

307 Weld seams may only be repaired twice in the same area, if agreed. Repeated repairs of the root in single sided welds are not permitted, unless specifically qualified and accepted in each case. Weld repairs shall be ground to merge smoothly into the original weld contour.

308 Repairs of the root pass in a single-sided joint for material meeting H₂S service requirements shall be carried out under constant supervision.

309 A local weld repair shall be at least 50 mm long or 4 times the material thickness, whichever is longest. A length at the bottom of the excavation is 50 mm may be acceptable if the taper required in G310 gives adequate access for welding.

310 The excavated portion of the weld shall be large enough to ensure complete removal of the defect, and the ends and sides of the excavation shall have a gradual taper from the bottom of the excavation to the surface. Defects can be removed by grinding, machining or air-arc gouging. Air-arc gouging shall be controlled by a documented procedure including the allowed variables according to AWS C5.3. If air-arc gouging is used, the last 3 mm through the root of the weld shall be removed by mechanical means and the whole excavated area shall be ground to remove any carbon enriched zones. The width and the profile of the excavation shall be sufficient to ensure adequate access for re-welding. Complete removal of the defect shall be confirmed by magnetic particle testing, or by dye penetrant testing for non ferromagnetic materials. Residuals from the NDT shall be removed prior to re-welding.

311 Weld repairs shall be ground to merge smoothly into the original weld contour.

312 Repair by welding after final heat treatment is not permitted.

313 A minimum ligament of 6 mm is required for partial thickness repair.

G 400 Post weld heat treatment

- 401** Welds shall be subjected to PWHT as specified in the pWPS or WPS and to a documented procedure.
- 402** Post weld heat treatment shall be performed for welded joints of C-Mn and low alloy steel having a nominal wall thickness above 50 mm, unless fracture toughness testing shows acceptable values in the as welded condition. In cases where the minimum design temperature is less than -10°C , the thickness limit shall be specially determined.
- 403** If post weld heat treatment is used to obtain adequate resistance of welded joints against sulphide stress cracking, this shall be performed for all thicknesses.
- 404** Whenever possible, PWHT shall be carried out by placing the welded assembly in an enclosed furnace. Requirements to PWHT in an enclosed furnace are given in Sec.8 D500.
- 405** If PWHT in an enclosed furnace is not practical, local PWHT shall be performed by means of electric resistance heating mats or other methods as agreed or specified. The PWHT shall cover a band over the entire length of the weld. The band shall be centred on the weld and the width of the heated band shall not be less than 5 times the thickness of the thicker component in the assembly.
- 406** Temperatures should be measured by thermocouples in effective contact with the material and at a number of locations to monitor that the whole length of the weld is heated within the specified temperature range. In addition temperature measurements shall be made to confirm that undesired temperature gradients do not occur.
- 407** Insulation shall be provided if necessary to ensure that the temperature of the weld and the HAZ is not less than the temperature specified in the pWPS or WPS. The width of the insulation shall be sufficient to ensure that the material temperature at the edge of the insulation is less than 300°C .
- 408** The rate of heating for C-Mn and low alloy steels above 300°C shall not exceed $5500/t^{\circ}\text{C} \cdot \text{h}^1$ and the rate of cooling while above 300°C shall not exceed $6875/t^{\circ}\text{C} \cdot \text{h}^1$ with t expressed in mm. During heating and cooling at temperatures above 300°C the temperature variation shall not exceed 35°C in any weld length of 1000 mm.
- The holding time at temperature should be minimum 30 minutes +2.5 minutes per mm thickness. Below 300°C the cooling may take place in still air.
- 409** The holding temperature for C-Mn low alloy steels should be within 580°C to 620°C unless otherwise specified or recommended by the material/welding consumable supplier. The maximum PWHT temperature for quenched and tempered low alloy steels shall be 25°C less than the tempering temperature of the material as stated in the material certificate.
- 410** The heat treatment temperature cycle charts shall be available for verification if requested.
- 411** For materials other than C-Mn and low alloy steels the PWHT heating and cooling rates, temperature, and holding time shall be as recommended by the material manufacturer.

G 500 Welding of pipeline girth welds

Production welding

- 501** These requirements apply to welding of girth welds in pipelines regardless of whether the welds are made onboard a laying vessel or at other locations, onshore or offshore. Girth welds in expansion loops, pipe strings for reeling or towing and tie-in welds are considered as pipeline girth welds.
- 502** The type of welding equipment and the welding procedure shall be qualified prior to installation welding.
- 503** In addition to the requirements given in G100 and G200, the requirements below shall apply for production welding of pipeline girth welds.
- 504** Bevels shall be prepared by machining. Beveling by thermal cutting shall be performed only when beveling by machining is not feasible e.g. for tie-in and similar situations. Bevels prepared by thermal cutting shall be dressed to obtain the final configuration. The beveling operator shall check the bevel configuration for compliance with suitable tools or gauges at regular intervals.
- 505** When welds are to be examined by manual or automated ultrasonic testing, reference marking shall be made on both sides of the joint as a scribed line around the pipe circumference. The reference marking shall be at a uniform and known distance from the root face of the bevel preparation. The distance from the root face and the tolerances shall be established, See also Appendix E, B108 and B1000.
- 506** All pipes shall be cleaned on the inside to remove any and all foreign matters and deposits in accordance with a documented procedure.
- 507** For S-lay welding, longitudinal welds shall be located in the top quadrant.
- 508** The longitudinal welds shall be staggered at least 50 mm. Installation girth welds shall be separated at least 1.5 pipe diameters or 500 mm, whichever is larger. For tie-in welds, both above seabed and hyperbaric, girth welds shall be separated by the maximum possible distance.
- 509** Excessive misalignment may be corrected by hydraulic or screw type clamps. Hammering or heating for

correction of misalignment is not permitted. Root gaps shall be even around the circumference. The final fit-up shall be checked with spacer tools prior to engaging line-up clamps or tack welding.

510 The use of mitre welds to correct angular misalignment of more than 3 degrees is not permitted.

511 Power operated internal line-up clamps shall be used whenever possible.

Internal line-up clamps shall not be released unless the pipe is fully supported on each side of the joint.

External line-up clamps shall not be removed unless the pipe is fully supported on each side of the joint and not before the completed parts of the root pass meet the requirements to length of each section, the spacing of the sections, the number of sections and the percentage of circumference required by the WPS.

512 Line-up clamps should not be removed before the first two passes are completed. For spool base welding the internal line up clamps may be removed after completing root pass when pipe is supported by rollers to ensure a smooth transfer from station to station. Reference is given to Sec.10 E203 regarding moving of pipe during installation welding.

513 If cables are present inside the pipeline, e.g. buckle detector cables, and radiographic testing is used, the starts and stops shall be made away from the six o'clock position to avoid masking of starts and stops on radiographs.

514 Copper contact tips and backing strips shall be checked on a regular basis for damage that could introduce copper contamination in welds. Damaged contact tips and backing strips shall be replaced.

515 Procedures shall be established for pre-cleaning, in process cleaning and post cleaning of welds.

516 If a pipe is to be cut for any reason, the cut shall be at a minimum distance of 25 mm from the weld toe. It is acceptable to cut less than 25 mm providing it can be documented by macrograph that the entire HAZ has been removed.

517 The root and the first filler pass shall be completed at the first welding station before moving the pipe. Moving the pipe at an earlier stage may be permitted if an analysis demonstrates that the pipe can be moved without any risk of introducing damage to the deposited weld metal. For spool base welding the pipe may be moved after completing root pass when pipe is supported by rollers to ensure a smooth transfer from station to station. See Sec.10 E203.

Repair welding

518 In addition to the requirements given in G300 the below requirements shall apply for repair welding of pipeline girth welds.

519 For through thickness repairs where the defects to be repaired are less than 100 mm apart, they shall be considered and repaired as one continuous defect.

520 The location of repair of burn through and other in process root repairs shall be marked on the outside of the pipe to inform NDT personnel that a root repair has been made.

521 If the pipe and the area of repair is not exposed to bending and/or axial stresses at the repair location when performing a repair, the length of a repair excavation shall not exceed 30% of the pipe circumference for partial penetration repairs and 20% of the pipe circumference for through thickness repairs.

522 Long defects may require repair in several steps to avoid yielding and cracking. The maximum length of allowable repair steps shall be calculated based on the maximum stresses present in the joint during the repair operation, and shall not exceed 80% of SMYS.

523 If the repair is performed at a location where the pipe and the area of repair is exposed to bending and axial stresses the allowable length of the repair excavation shall be determined by calculations, see Sec.10 E202 and E203.

524 If repairs can not be executed according to the requirements above, or are not performed successfully, the weld shall be cut out.

525 Full records of all repairs, including in-process root repairs, shall be maintained.

Production tests

526 Production tests shall be performed in a manner which, as far as possible, reproduces the actual welding, and covers the welding of a sufficient large pipe section in the relevant position. All welding stations on the production line shall be used to produce the production test weld. Production welds cut out due to NDT failure may be used.

527 Production tests should be performed for each Welding Procedure Specification (WPS) used for welding of the pipeline girth welds. All welding stations/productions lines shall be covered. Production tests should be performed as early as possible in the construction phase, e.g. within the first 100 welds.

Guidance note:

Production tests also applies to welding onshore for e.g. installation by reeling. Production tests may also be performed on the vessel prior to start installation welding, e.g. when the vessel is moving to the pipelaying start destination.

---e-n-d---of---G-u-i-d-a-n-c-e---n-o-t-e---

528 Production tests should not be required for welding procedures qualified specifically for tie-in welds, flange welds, Tee-piece welds etc.

529 The extent of production tests shall be expanded if:

- the Contractor has limited previous experience with the welding equipment and welding methods used
- the welding inspection performed is found to be inadequate
- severe defects occur repeatedly
- any other incident indicates inadequate welding performance
- the installed pipeline is not subjected to system pressure testing, see Sec.5 B202.

530 The extent of production testing shall be consistent with the inspection and test regime and philosophy of the pipeline project.

531 Production tests shall be subject to the non-destructive, macro, hardness, all weld tensile, Charpy V-notch fracture toughness (when applicable) testing as required in Appendix C for Welding Procedure Qualification Testing (WPQT).

532 If production tests show unacceptable results, appropriate corrective and preventative actions shall be initiated and the extent of production testing shall be increased.

G 600 Welding and PWHT of pipeline components

601 The Manufacturer shall be capable of producing pipeline components of the required quality.

602 Welding and PWHT shall be performed in accordance with G100 through G400 above.

603 Production tests shall be performed in a manner which, as far as possible, reproduces the actual welding, and covers the welding of a sufficient large test section in the relevant position. All welding stations on the production line shall be used to produce the production test weld. Production welds cut out due to NDT failure may be used.

H. Material and Process Specific Requirements

H 100 Internally clad/lined carbon steel and duplex stainless steel

WPS

101 In addition to the applicable data given in Table C-1, the WPS shall specify the following, as recorded during the welding procedure qualification:

- the minimum time period of backing gas application prior to start of welding
- the minimum time period of backing gas application during welding
- the minimum time period of backing gas application after welding
- description of the back-purge dam type and method.

Essential variables

102 The following essential variables shall apply in addition to those in Table C-2:

- any reduction of the time of backing gas application prior to start of welding
- any reduction in the number of passes completed before stopping back-purging.

Welding consumables for clad/lined carbon steel

103 For single sided (field) joints, the same type of welding consumable should be used for all passes needed to complete the joint. Alternative welding consumables may be considered for fill and capping passes after depositing a weld thickness not less than 2 times thickness of the cladding/lining. The alternative welding consumables shall be documented to be compatible with the welding consumables used for the root area, the base material and the applicable service conditions. Welding consumables for clad/lining shall be segregated from consumables for C-Mn steel.

Welding consumables for duplex steel

104 Welding consumables with enhanced nickel and nitrogen content shall be used unless full heat treatment after welding is performed. Sufficient addition of material from the welding consumables is essential for welding of the root pass and the two subsequent passes. Welding consumables shall be segregated from consumables for C-Mn steel.

Backing and shielding gases

105 Backing and shielding gases shall not contain hydrogen and shall have a dew point not higher than -30°C . The oxygen content of the backing gas should be less than 0.1% during welding of the root pass. Backing gas shall be used for welding of root pass and succeeding passes. (Exception from this requirement may be tie-in welds when stick electrodes are used for root bead welding, subject to agreement.)

Production

106 Welding of clad/lined carbon steel and duplex stainless steel may be performed by the welding processes listed in A200. The welding shall be double sided whenever possible. Welding of the root pass in single sided joints will generally require welding with Gas Tungsten Arc Welding (GTAW / 141) or Gas Metal Arc Welding (GMAW / 135).

107 Onshore fabrication of clad/lined carbon steel and duplex stainless steel shall be performed in a workshop, or part thereof, which is reserved exclusively for this type of material. During all stages of manufacturing, contamination of CRA and duplex steel with carbon steel and zinc shall be avoided. Direct contact of the CRA with carbon steel or galvanised handling equipment (e.g. hooks, belts, rolls, etc.) shall be avoided. Tools such as earthing clamps, brushes etc, shall be stainless steel suitable for working on type of material in question and not previously used for carbon steel. Contamination of weld bevels and surrounding areas with iron and low melting point metals such as copper, zinc, etc. is not acceptable. The grinding wheels shall not have previously been used for carbon steel. Parts of internal line-up clamps that come in contact with the material shall be non-metallic or of a similar alloy as the internal pipe surface. Thermal cutting shall be limited to plasma arc cutting.

108 The weld bevel shall be prepared by milling or other agreed machining methods. The weld bevel and the internal and external pipe surface up to a distance of at least 25 mm from the bevels shall be thoroughly cleaned with an organic solvent.

109 Welding consumables shall be segregated from consumables for C-Mn / low alloy steels.

110 The backing gas composition shall be monitored using an oxygen analyser immediately prior to starting or re-starting welding. The flow rate of the back purge gas shall be adjusted to prevent gas turbulence and possible air entrainment through open weld seams.

111 Inter-run cleaning shall be by grinding to bright, defect free material for all passes.

112 Internal high-low of clad/lined pipes shall not exceed 1 mm unless otherwise qualified or if the cladding at pipe ends has a thickness increase allowing larger misalignment. In any case the internal high-low shall not reduce the thickness of the CRA below the specified thickness. Internal high-low of duplex stainless steel linepipe shall not exceeded 2 mm or 1% of the pipe internal diameter, whichever is less, unless otherwise qualified.

113 Welds shall be multipass and performed in a continuous operation.

114 The interpass temperature shall be measured directly where a weld run will start and terminate. The weld zone shall be kept below the maximum interpass temperature before a welding run is started. Unless post weld heat treatment is performed, the maximum interpass temperature shall not exceed 150°C for all CRAs.

115 When clad/lined C-Mn linepipe is cut and/or re-bevelled a lamination check by through thickness ultrasonic testing and dye penetrant testing on the bevel face shall be performed. If a laminar discontinuity is detected on the bevel face the cladding/liner shall be removed and a seal weld shall be overlay welded at the pipe end.

Additional for welding of duplex steel

116 The heat input must be controlled to avoid detrimental weld cooling rates. For optimum control of the heat input faster welding speeds and associated higher welding current should be used. Stringer beads shall be used to ensure a constant heat input, and any weaving of the weld bead should be limited to maximum 3X filler wire/electrode diameter. For girth welds the heat input should be kept within the range 0.5 - 1.8 kJ/mm and avoiding the higher heat input for small wall thicknesses. For wall thickness > 25 mm and provided post weld heat treatment (solution annealing) is performed a maximum heat input of 2.4 kJ/mm is acceptable. For the root pass the heat input shall be higher than for second pass. For SAW welding small diameter wire and modest welding parameters (high travel speed and low arc energy) shall be used. The depth to width ratio of the weld deposit shall be less than 1.0.

117 Solution annealing post weld heat treatment shall be performed in accordance with qualified heat treatment procedure.

118 Excavation of repair grooves shall be by chipping, grinding or machining. Air-arc gouging shall not be used. Entire welds shall be removed by plasma cutting or machining. Repeated repairs are not permitted.

119 All operations during welding shall be carried out with adequate equipment and/or in a protected environment to avoid carbon steel contamination of the corrosion resistant material. Procedures for examination of surfaces and removal of any contamination shall be prepared.

H 200 13Cr Martensitic stainless steel

WPS and essential variables

201 The additional data for the WPS and the essential variables given in H101 and H102 also applies to 13Cr martensitic stainless steels.

Welding consumables

202 The requirements to backing and shielding gases in H105 also apply to 13Cr MSS.

Production

203 Welding of 13Cr MSS may be performed by the welding processes listed in A200, except active gas shielded methods. The welding shall be double sided whenever possible.

204 During all stages contamination of 13Cr MSS with carbon steel and zinc shall be avoided. Direct contact with carbon steel or galvanised handling equipment (e.g. hooks, belts, rolls, etc.) shall be avoided. Tools such as earthing clamps, brushes etc., shall be stainless steel suitable for working on type of material in question and not previously used for carbon steel. Contamination of weld bevels and surrounding areas with iron and low melting point metals such as copper, zinc, etc. is not acceptable. The grinding shall not have previously been used for carbon steel. Parts of internal line-up clamps that come in contact with the material shall be non-metallic or of a similar alloy as the internal pipe surface. Thermal cutting shall be limited to plasma arc cutting.

205 The weld bevel shall be prepared by milling or other agreed machining methods. The weld bevel and the internal and external pipe surface up to a distance of at least 25 mm from the bevels shall be thoroughly cleaned with an organic solvent.

206 Welding consumables shall be segregated from consumables for C-Mn steel.

207 The backing gas composition shall be monitored using an oxygen analyser immediately prior to starting or re-starting welding. Care shall be taken to adjust the flow rate of the back purge gas to prevent gas turbulence and possible air entrainment through open weld seams.

208 The interpass temperature shall be measured directly at the points where a welding run will start and terminate. The weld zone shall be below the maximum interpass temperature before a welding run is started. The maximum interpass temperature shall not exceed 150°C.

209 PWHT (e.g. ≈ 5 minutes at $\approx 630^\circ\text{C}$) should be performed in accordance with the PWHT procedure qualified during welding qualification.

210 Excavation of repair grooves shall be by chipping, grinding or machining. Air-arc gouging shall not be used. Entire welds shall be removed by plasma cutting or machining.

211 All operations during welding shall be carried out with adequate equipment and/or in a protected environment to avoid carbon steel contamination of the corrosion resistant material. Procedures for examination of surfaces and removal of any contamination shall be prepared.

H 300 Pin brazing and aluminothermic welding

301 Anode leads may be attached by pin brazing or aluminothermic welding according to qualified procedures including full details of the technique used and associated equipment.

Qualification of operators

302 Operators that have performed a qualified procedure test are thereby qualified.

303 Other operators shall prior to carrying out operation work, each complete three test pieces made in accordance with the procedure specification under realistic conditions. Each test piece shall pass the test for electrical resistance and mechanical strength according to Table C-6 and F500.

Essential variables

304 Essential variables for pin brazing and aluminothermic welding shall be:

Base material grade and chemical composition:

- a change in grade
- a change in the supply condition (TMCP, Q/T or normalised)
- any increase in P_{cm} of more than 0.02, CE of more than 0.03 and C content of more than 0.02% for C-Mn linepipe.

For both methods a change in:

- cable dimension
- process (brazing or aluminothermic welding)
- make, type and model of equipment
- method for cleaning and preparation of cable ends and cable attachment area.

For Aluminothermic welding a change in:

- type, classification and brand of start and welding powder
- type, make and model of other consumables
- volume (cartridge, packaging type) and type of start and welding powder that will change the heat input by more than $\pm 15\%$.

For Pin brazing a change in:

- type, composition, make and model of pin for pin brazing
- the minimum preheat or working temperature
- range of equipment settings for pin brazing
- the equipment earth connection area.

Production requirements for welding/brazing of anode leads

305 The anode cable attachments shall be located at least 150 mm away from any weld.

306 For cable preparation cable cutters shall be used. The insulation shall be stripped for the last 50 mm of the cable to be attached. The conductor core shall be clean, bright and dry. Greasy and oily conductor cores shall be cleaned with residue free solvent or dipped in molten solder. Corroded conductor cores shall be cleaned to bright metal with brush or other means. Wet conductor cores shall be dried by rapid drying residue free solvent, alcohol or hand torch.

307 The cable attachment area, and for pin brazing also the equipment earth connection area, shall be cleaned for an area of minimum 50 mm \times 550 mm. All mill scale, rust, grease, paint, primer, corrosion coating, and dirt shall be removed and the surface prepared to finishing degree St 3 according to ISO 8501-1. The surface shall be bright, clean and dry when welding/brazing is started.

Production testing

308 Each welded/brazed anode lead shall be subjected to electrical resistance test and mechanical strength test according to Table C-6 with acceptance criteria according to F500.

Repair of welded/brazed anode leads

309 Welded/brazed anode leads not meeting the requirements in F500 shall be removed and the affected area shall be removed by grinding.

310 For welded/brazed anode leads that are attached directly onto pressure containing parts the ground areas shall blend smoothly into the surrounding material. Complete removal of defects shall be verified by local visual inspection and polishing and etching to confirm removal of copper penetration. The remaining wall thickness in the ground area shall be checked by ultrasonic wall thickness measurements to verify that the thickness of the remaining material is more than the specified minimum. Imperfections that encroach on the minimum permissible wall thickness shall be classified as defects.

I. Hyperbaric Dry Welding

I 100 General

101 Underwater welding on pressure containing components for hydrocarbons shall be carried out utilising a low hydrogen process, in a chamber (habitat) where the water has been displaced. Other methods can be used on non-pressure containing components subject to special acceptance by Purchaser.

102 All relevant welding parameters shall be monitored and recorded at the surface control station under supervision by a welding co-ordinator. The welding area shall have continuous communication with the control station. All operations including welding shall be monitored by a video system that can be remotely controlled from the control station.

I 200 Qualification and testing of welding personnel for hyperbaric dry welding

Hyperbaric welding co-ordinator

201 The welding co-ordinator for hyperbaric dry welding shall have adequate experience with welding procedure qualification and offshore operations for the hyperbaric welding and welding related system used.

202 The welding co-ordinator shall, when applicable, have completed the training programme required for mechanised welding required in I204 to I206.

Welders for hyperbaric welding

203 Prior to qualification testing for underwater (hyperbaric) dry welding of girth welds, welders shall have passed a welding test for pipeline girth welds as specified in B200 above.

Training programme

204 The hyperbaric welders shall be informed on all aspects of the work related to the welding operation, the

qualified welding procedures, the applicable technical specifications and layout of the welding and habitat system.

205 Hyperbaric welders shall receive a training programme and pass an examination upon completion of the programme. The training programme shall be structured according to Annex B of ISO 15618-2.

206 In addition, for mechanised welding the training programme shall include:

- software structure of welding programme and loading of any welding programme prior to start of welding
- perform a complete butt weld, from programming of the welding parameters to welding of the cap passes
- repair welding
- daily maintenance of the welding equipment
- knowledge about the functions of the welding heads and how to replace consumables such as welding wire, contact tubes, gas nozzles and tungsten electrodes.

Test welding

207 The hyperbaric welders shall perform a qualification test using welding equipment identical or equal in function to the hyperbaric welding equipment used for production welding.

208 The qualification welding for hyperbaric welding shall be performed in accordance with ISO 15618-2.

Qualification testing of welders

209 For welder qualification for dry hyperbaric welding of girth welds and other butt weld configurations the test pieces shall be subject to same the testing and acceptance criteria as for pipeline girth welds in B200.

210 A welder is deemed qualified for the applicable ranges of approval stated in Clause 6 of ISO 15618-2 when the following requirements for inspection and testing of test pieces, as applicable, are met:

- 100% visual examination and 100% ultrasonic testing with test requirements and acceptance criteria in accordance with Appendix D
- macro-examination according to Appendix B. The specimen shall meet the requirements of ISO 15618-2, Chapter 8
- if 100% radiographic testing with test requirements and acceptance criteria in accordance with Appendix D is performed in lieu of 100% ultrasonic testing, bend testing as required in ISO 9606 shall be performed for all welding processes.

Retesting

211 See ISO 15618-2, Chapter 9.

Period of validity and prolongation

212 The period of validity shall be 6 months, and the prolongation in accordance with ISO 15618-2, paragraph 10.2.

I 300 Welding processes for hyperbaric dry welding

301 The allowable welding processes are:

- SMAW (Process ISO 4063-111)
- G-FCAW (Process ISO 4063-137)
- GMAW (Process ISO 4063-131)
- GTAW (Process ISO 4063-141).

I 400 Welding consumables for hyperbaric dry welding

401 In addition to the requirements given in C100 to C400 the following shall apply:

- consumables should be of a type that is tested or developed for dry hyperbaric welding with respect to arc stability and metal transfer behaviour and mechanical properties
- procedures for transfer of consumables to the hyperbaric chamber and for consumable handling in the chamber, including disposal of unused exposed consumables. The procedure shall particularly consider the maximum humidity expected during production welding
- all consumables for qualification of the welding procedure shall be from the same batch, a consumable batch being defined as the volume of product identified by the supplier under one unique batch/lot number, manufactured in one continuous run from batch/lot controlled raw materials.

I 500 Shielding and backing gases for hyperbaric dry welding

501 In addition to the requirements given in C500 the following shall apply:

- the purity of shielding and backing gases shall be 99.995 for Ar and 99.997% for He. The maximum allowable moisture content in the gas used in the actual welding is governed by the moisture content of the gas used during the qualification welding.

Guidance note:

The dew point temperature at atmospheric pressure (1 bar) is often used to specify the upper level acceptance criteria for the moisture content in shielding gases. However, for hyperbaric conditions, even a low dew-point temperature (e.g. -30°C for an Argon gas) can result in condensation of water at the relevant working depth/pressure and temperature (e.g. at 165 m at 5°C). This means that the gas is saturated with water when used at this depth and condensed water will be present at greater depths. In general the acceptance level for the water content in the shield gas must be specified precisely. The use of “ppm” alone is not sufficient. It must be related either to volume or weight of the gas.

It is the water concentration in the gas at the working depth/pressure which is essential. This can be specified as weight of the water per volume unit (mg H₂O/m³) or partial pressure of the H₂O (millibar H₂O).

---e-n-d---of---G-u-i-d-a-n-c-e---n-o-t-e---

I 600 Welding equipment and systems for hyperbaric dry welding

601 In addition to the requirements given in B100 the following shall apply unless the voltage is measured at the arc during both qualification and production welding:

- Welding cables shall have the same dimension and approximately the same resistance during the welding procedure qualification and production welding. If necessary artificial resistance to simulate the full cable length used in production should be used during qualification welding.

I 700 Welding procedures for hyperbaric dry welding

Contents of pWPS

701 A pWPS shall be prepared for each welding and repair welding procedure that will be qualified for use during welding of pipeline girth welds.

702 The pWPS shall contain the information required for the applicable welding processes, including any tack welds and shall be prepared in accordance with Table C-1 and shall propose limits and ranges for the applicable essential variables for welding and repair welding procedures given in Table C-2 and Table C-8.

703 In addition the pWPS shall address the following:

- vent hole, number of runs to be deposited before closing the root and methods for closing the root
- conditions for release of external line-up clamps including the percentage of the circumference for the welded root sections, the length of each section and spacing of the sections
- water depth (minimum/maximum)
- pressure inside the chamber
- gas composition inside the chamber
- humidity, maximum level
- temperature inside the chamber (minimum/maximum)
- length, type and size of the welding umbilical
- position for voltage measurements
- welding equipment.

704 The welding procedures for closing possible vent holes shall also be qualified. This qualification test should as a minimum include impact testing of weld metal, FL, FL+2, FL+5, macro/hardness testing and for CRA also metallographic examination. The qualification may be performed as a “buttering” test providing considerations are made to start/stop and that access limitations for the actual production welding is simulated.

Essential variables

705 The essential variables for hyperbaric dry welding shall be according to Table C-2 with additional requirements according to Table C-8 below.

Table C-8 Additional essential variables for hyperbaric dry welding		
<i>A Qualified water depth for SMAW and GTAW¹⁾</i>		
Water depth (WD) in metres:	1	WD ≤ 200 m: Any increase in excess of + 20% or 10 m or whichever is greater.
	2	200 m < WD ≤ 300 m: ± 10%
	3	300 m < WD ≤ 500 m: ± 10%
<i>B Habitat environment</i>		
Gas composition (argon, heliox, air or nitrox), and humidity	1	For water depth ≤ 200 m: A change from argon or heliox to air or nitrox but not vice versa
	2	For water depth > 200 m: Any change in gas composition
	3	Any increase in relative humidity for SMAW and G-FCAW flux based welding processes otherwise any increase in excess of + 10%
<i>C Monitoring of electrical parameters</i>		
Method and point of monitoring	1	Any change
Note		
1) For other processes the depth of qualification shall be agreed.		

I 800 Qualification welding for hyperbaric dry welding

801 Qualification welding shall be performed in the habitat at a water depth selected in accordance with the intended range of qualification, or under appropriately simulated conditions. The qualification test program shall consist of a minimum of one completed joint for manual welding, and a minimum of three joints for mechanised welding systems.

802 Qualification welding shall comply with E100 and the following additions:

- for SMAW welding shall be performed at the maximum expected humidity in the chamber during production welding
- the power source and the technical specification for the welding system shall be equivalent to the production system
- the pipes shall be rigidly fixed to simulate restraint during welding
- method and position/point for monitoring of electrical parameters shall be as for production welding
- with increasing pressure the voltage gradient will increase. Accordingly may small changes in arc length and or operating depth result in considerable changes in the monitored values of arc voltage. For calculations of the heat input, the arc voltage shall be recorded at the position/point of welding during qualification of the welding procedure and the difference between these values and remote monitored values recorded for use during production welding.

Repair welding procedures

803 Qualification welding shall be performed in compliance with the requirements given in E200.

I 900 Qualification of welding procedures for hyperbaric dry welding

901 The requirements given in E300 shall apply.

I 1000 Examination and testing

1001 Examination and testing shall be in accordance with F100, F200 and F300.

I 1100 Production welding requirements for dry hyperbaric welding

1101 In addition to the applicable requirements given in G, H100 and H200, the requirements below shall apply for dry hyperbaric production welding:

1102 The habitat shall be of adequate size to allow access for welding and for all necessary welding, safety and life support equipment. Further the habitat shall be lighted and be fitted with remote cameras for surveillance. Welding fumes shall not prevent the use of the remote cameras in the welding area.

1103 A function test of the habitat, habitat equipment and the monitoring and communication equipment shall be performed to a written and agreed procedure, and accepted before lowering the habitat to the working position. The function test shall also include verification of that the welding parameters are applied correctly on the actual equipment.

1104 If used, shielding and/or backing gas shall be of qualified purity including moisture limit. Gas purity and composition in all containers shall be certified and traceable to the gas storage containers. The gas purity and moisture content shall be verified after purging the gas supply system prior to start of welding. The moisture content of the shielding gas shall be monitored at/near the torch during welding operation.

1105 Pup pieces shall be bevelled, checked for correct length, laminations at cut ends and the bevel profile.

1106 At completion of positioning of the two pipe sections to be welded, the following information, as a minimum, shall be reported to the surface:

- pipe sections to be connected (pipe number, heat number if possible)
- approximate distance from the girth weld to the pipe extremity
- position of the longitudinal welds.

1107 If the requirement for staggering of longitudinal welds can not be met, any reduction in the separation of welds shall be limited to two pipe lengths.

1108 All operations including welding shall be monitored by a video system that can be remotely controlled from the control station and the welding area shall have continuous communication with the control station. All relevant data shall be monitored and recorded at the surface control station under supervision by the welding co-ordinator, including:

- environmental conditions (humidity, temperature, atmosphere composition)
- welding parameters (mechanised and automatic welding)
- gas moisture content
- preheat and interpass temperature
- information transmitted by the welders.

1109 The following records shall be presented as part of the documentation:

- chart recordings of welding current, arc voltage, filler wire speed, welding speed
- video recording from the weld observation cameras.

Weld repair

1110 The applicable requirements given Table C-7 shall apply. In addition repairs exceeding 30% of pipe D shall be performed only if agreed.

APPENDIX D

NON-DESTRUCTIVE TESTING (NDT)

A. General

A 100 Objective

101 This Appendix specifies the requirements for methods, equipment, procedures, acceptance criteria and the qualification and certification of personnel for visual examination and non-destructive testing (NDT) of C-Mn steels, low alloy steels, duplex steels, other stainless steels and clad steel materials and weldments for use in pipeline systems.

102 This Appendix does not cover automated ultrasonic testing (AUT) of girth welds. Specific requirements pertaining to AUT of girth welds are given in Appendix E.

103 Requirements for NDT and visual examination of other materials shall be specified and be in general agreement with the requirements of this Appendix.

A 200 Applicability of requirements

201 The requirements in this Appendix are given in several subsections with each subsection dealing with the non-destructive testing of specific objects.

202 The requirements given in subsection A are applicable for the whole of this Appendix.

203 The requirements given within the other subsections are applicable only to the scope of the subsection as indicated in the title of the subsection, unless specific references to other subsections are made.

A 300 Quality assurance

301 NDT Contractors and organisations shall as a minimum have an implemented quality assurance system meeting the general requirements of ISO 9001 and supplemented with the requirements given in ASTM E1212.

A 400 Non-destructive testing methods

401 Methods of NDT shall be chosen with due regard to the conditions influencing the sensitivity of the methods. The ability to detect imperfections shall be considered for the material, joint geometry and welding process used.

402 As the NDT methods differ in their limitations and/or sensitivities, combination of two or more methods shall be considered since this is often required in order to ensure optimum probability of detection of harmful defects.

403 Magnetic particle, eddy current or magnetic flux leakage testing is preferred for detection of surface imperfections in ferromagnetic materials. For detection of surface imperfections in non-magnetic materials, either liquid penetrant testing or eddy current testing shall be preferred.

404 Ultrasonic and/or radiographic testing shall be used for detection of internal imperfections. It may be necessary to supplement ultrasonic testing by radiographic testing or vice versa, in order to enhance the probability of detection or characterisation/sizing of the type of flaws that can be expected, as specified in Sec.10, E300.

Radiographic testing is preferred for detection of volumetric imperfections. For material thicknesses above 25 mm radiographic testing should always be supplemented by ultrasonic testing.

Ultrasonic testing shall be preferred for detection of planar imperfections and whenever determination of the imperfection height and depth is necessary, e.g. as a result of an ECA, ultrasonic testing is required.

Guidance note:

The detectability of cracks with radiographic testing depends on the crack height, the presence of branching parts of the crack, the direction of the X-ray beam to the orientation of the crack and radiographic technique parameters. Reliable detection of cracks is therefore limited.

Lack of sidewall fusion will probably not be detected unless it is associated with volumetric imperfections or if X-ray beam is in the direction of the side-wall.

---e-n-d---of---G-u-i-d-a-n-c-e---n-o-t-e---

405 When manual non-destructive testing in special cases is used as a substitute for automated ultrasonic testing for pipeline girth welds, both radiographic and ultrasonic testing of the girth weld shall be performed.

406 Alternative methods or combination of methods for detection of imperfections may be used if the methods are demonstrated as capable of detecting imperfections with an acceptable equivalence to the preferred methods.

A 500 Personnel qualifications

Manual or semi-automatic NDT

501 Personnel performing manual or semi-automated NDT and interpretation of test results shall be certified to Level 2 by a Certification Body or Authorised Qualifying Body in accordance with EN 473, ISO 9712 or the ASNT Central Certification Program (ACCP). Personnel qualification to an employer based qualification scheme as SNT-TC-1A may be accepted if the employer's written practice is reviewed and found acceptable and the Level 3 is ASNT Level III or ACCP Professional Level III and certified in the applicable method. Company appointed Level 3 is not accepted.

Ultrasonic operators performing testing of welds including austenitic or duplex stainless steel material, shall be specially trained and qualified for the purpose according to EN 473, ISO 9712 or equivalent scheme.

Automated NDT, general

502 Personnel calibrating equipment and interpreting results from automated equipment for NDT shall be certified to an appropriate level according to a certification scheme meeting the requirements of 501. In addition, they shall be able to document adequate training and experience with the equipment in question, and shall be able to demonstrate their capabilities with regard to calibrating the equipment, performing an operational test under production/site/field conditions, and evaluating size and location of imperfections.

Automated NDT, linepipe manufacture

503 Personnel operating automated equipment for NDT during manufacture of linepipe shall be certified according to ISO 11484 or equivalent certification scheme.

Preparation of NDT procedures

504 Preparation of NDT procedures and execution of all NDT shall be carried out under the responsibility of Level 3 personnel. Any tasks involving calibration of the equipment, data acquisition and interpretation of the results, shall include personnel qualified to at least Level 2 of applicable NDT method.

Visual examination

505 Personnel performing visual examination of welds shall have documented training and qualifications according to NS 477, minimum CSWIP3.2.1 (Level 3) or minimum IWI-S or equivalent certification scheme. Personnel performing visual examination of other objects shall have training and examination according to a documented in-house standard. Personnel performing visual testing of finished, welded joints shall be qualified as stated above or in accordance with EN 473 or ISO 9712, VT level 2, or equivalent.

Visual acuity

506 Personnel interpreting radiographs, performing ultrasonic testing, interpreting results of magnetic particle and liquid penetrant testing and performing visual examination shall have passed a visual acuity test such as required by EN 473 and ISO 9712 or a Jaeger J-w test at 300 mm, within the previous 12 months.

A 600 Timing of NDT

601 Whenever possible, NDT of welds shall not be performed until 24 hours has elapsed since completion of welding.

602 If welding processes ensuring a diffusible hydrogen content of maximum 5 ml/100 g of weld metal are used, adequate handling of welding consumables is verified, shielding gas content of H₂ is controlled, or measures (such as post heating of the weldment) are taken to reduce the contents of hydrogen, the time in 601 above can be reduced, subject to agreement.

603 NDT of pipeline installation girth welds and longitudinal welds in linepipe can be performed as soon as the welds have cooled sufficiently to allow the NDT to be performed.

B. Manual Non-Destructive Testing and Visual Examination of Welds

B 100 General

101 Manual non-destructive testing of welds shall be performed in compliance with the standards listed below and as required in the following:

DNV classification note No. 7, Non Destructive Testing

Radiography ISO 17636

Digital Radiography ISO/DIS 17636-2

Ultrasonic ISO 17640

Magnetic Particle ISO 17638

Liquid Penetrant ISO 3452 all parts

Eddy Current ISO 17643

Visual examination ISO 17637

Non-destructive testing procedures

102 Non-destructive testing shall be performed in accordance with written procedures that, as a minimum, give information on the following aspects:

- applicable code(s) or standard(s)
- welding method (when relevant)
- joint geometry and dimensions
- material(s)
- method
- technique
- equipment main and auxiliary
- consumables (including brand name)
- sensitivity
- calibration techniques and calibration references
- testing parameters and variables
- assessment of imperfections
- reporting and documentation of results
- reference to applicable welding procedure(s),
- example of reporting forms
- acceptance criteria.

103 If alternative methods or combinations of methods are used for detection of imperfections, the procedures shall be prepared in accordance with an agreed code or standard. The need for procedure qualification shall be considered in each case based on the method's sensitivity in detecting and characterising imperfections and the size and type of defects to be detected.

104 All non-destructive testing procedures shall be signed by the responsible Level III person.

Reporting

105 All NDT shall be documented such that the tested areas may be easily identified and such that the performed testing can be duplicated. The reports shall identify the defects present in the weld area and state if the weld satisfies the acceptance criteria or not.

106 The report shall include the reporting requirements of the applicable standard, NDT procedure and acceptance criteria.

At least the following minimum information must be given:

- Name of the company and operator carrying out the testing including certification level of the operator
- Object and drawing references
- Place and date of testing
- Material type and dimensions
- Post weld heat treatment, if required
- Location of examined areas, type of joint
- Welding process used
- Surface conditions
- Temperature of the object
- Number of repairs if specific area repaired twice or more
- Contract requirements e.g. order no., specifications, special agreements etc.
- Example of reporting forms
- Sketch showing location and information regarding detected defects
- Extent of testing
- Test equipment used
- Description of the parameters used for each method
- Description and location of all recordable indications
- Testing results with reference to acceptance level
- Other information related to the specific method may be listed under each method.

B 200 Radiographic testing of welds

201 Radiographic testing shall be performed in compliance with ISO 17636 and DNV classification note 7, and as required below.

202 Radiographic testing shall be performed by use of X-ray according to accepted procedures. Use of radiographic isotopes (gamma rays) may be required in some situations and is subject to agreement in each case.

Radiographic testing procedures

203 Radiographic testing procedures shall be according to B102 through B104 and include:

- radiographic technique class
- radiation source
- technique
- geometric relationships
- film type
- intensifying screens
- exposure conditions
- processing
- Image Quality Indicator sensitivities in percent of the wall thickness, based on source and film side indicators respectively
- backscatter detection method
- density
- film side Image Quality Indicator (IQI) identification method
- film coverage
- weld identification system.

Classification of radiographic techniques

204 The radiographic techniques used shall be according to Class B and the requirements below.

205 Class B techniques should also be used when using gamma ray sources.

If, for technical reasons, it is not possible to meet one of the conditions specified for Class B, the note to Chapter 5 of ISO 17636 shall apply.

Image Quality Indicators

206 Image Quality Indicators (IQIs) shall meet the requirements given in ISO 19232. The wire material shall have a coefficient of absorption as close as possible to the material tested. If the absorption coefficients of the IQI material and the material tested differ by more than 20%, an experimental evaluation according to ISO 19232-4 shall be performed to establish the acceptable image quality values.

Sensitivity

207 The sensitivities obtained during production radiography shall at least meet the requirements of ISO 17636, Annex A except for double wall techniques with the IQI on the film side. For this technique, the sensitivity of the film side IQI from the procedure qualification shall be used as acceptance criterion for film sensitivity.

Radiographic procedure qualification

208 Each radiographic procedure and the consumables used shall be qualified by making radiographic exposures of a welded joint or base material with the same or typical configuration and dimensions, and of material equivalent to that which shall be used in production radiography.

For procedures using source side IQIs, the sensitivity shall meet the applicable criterion in ISO 17636, Annex A and the average density at the sound weld metal image shall be minimum 2.0. The maximum density allowed shall be according to the capabilities of the available viewing equipment, but not more than 4.0.

209 For procedures using film side IQIs, the IQIs shall for radiographic procedure qualification purposes be placed on both the film side and the source side.

The sensitivity of the source and film side IQIs shall both satisfy the applicable criteria in ISO 17636, Annex A and the density shall meet the requirements of 208.

If the sensitivity of the film side IQI is better than required by the applicable criterion in ISO 17636, Annex A the film side sensitivity obtained during procedure qualification shall be recorded and be acceptance criterion for the sensitivity of the film side IQI during production radiography.

Processing and storage

210 Processing of radiographs shall conform to ISO 17636. Storage shall be such that the radiographs maintain their quality for a minimum of 5 years without deterioration. Thiosulphate tests shall be performed at regular intervals.

If radiograph storage time in excess of 5 years is required, the radiographs should be digitised using methods giving adequate resolution and stored in electronic media in an agreed manner.

Reporting

211 Reports shall be in accordance with B105 and B106. In addition to the items listed in ISO 17636 the following shall be included in the radiographic testing report:

- radiographic procedure reference
- geometric unsharpness.

Digital Radiography and Radioscopic testing

212 Digital radiographic testing techniques in accordance with ISO/DIS 17636-2 and if relevant: EN 13068 and EN14784, may be used provided the equipment has been qualified, in accordance with Subsection F, to give sensitivity and detection equivalent to conventional x-ray according to ISO 17636. Digital radiography shall be according to Class B or better, as described in ISO/DIS 17636-2. When ISO/DIS 17636-2 is officially issued, the official version of ISO 17636-2 will apply, and hence the reference to ISO 17636 will be to ISO 17636-1.

Digital radiographic testing of weld seam of welded steel tubes shall be according to ISO 10893-7.

Specific requirements to radiography of installation girth welds

213 For radiography the following additional requirements shall apply for installation girth welds:

- Panoramic (single wall single image) exposures shall be used whenever possible
- Fluorimetallic screens may be used in combination with X-ray based on a satisfactory procedure qualification test where all requirements to sensitivity are met. Films used with fluorimetallic screens shall be designed for use with this screen type
- For pipe with internal diameter < 250 mm gamma ray and panoramic (single wall single image) exposures may be used. The gamma ray source should be Se 75 used with a film system class better than C4 according to ISO 17636, Table 3. Other types of radiation sources may be used for small wall thicknesses in combination with other film types. The use of gamma ray sources shall always be based on a satisfactory procedure qualification test where all requirements to sensitivity are met
- Where no internal access is possible, a double wall technique shall be applied
- For the double wall double image technique x-ray shall be used. Fluorimetallic screens may be used based on a satisfactory procedure qualification test where all requirements to sensitivity are met. Films for use with fluorimetallic screens shall be suitable for this screen type
- For the double wall single image technique both X-ray and gamma ray may be used. The choice of radiation source, film and screen types shall be based on a satisfactory procedure qualification test where all requirements to sensitivity are met.

B 300 Manual ultrasonic testing of welds in C-Mn/low alloy steel with C-Mn/low alloy steel weld deposits

301 Ultrasonic testing shall be performed in compliance with ISO 17640 and as required below.

302 Ultrasonic testing shall be performed according to accepted procedures. The procedure shall be established according to DNV classification note 7.

Ultrasonic testing procedures

303 Ultrasonic testing procedures shall be according to B102 through B104 and DNV classification note 7 and, include:

- type of instrument
- type and dimensions of probes
- range of probe frequencies
- description of reference block
- calibration details, range and sensitivity
- surface requirements, including maximum temperature
- type of coupling medium
- scanning techniques supplemented with sketches, showing the probes used and area covered
- recording details.

304 Typical applications, which require specific UT procedures, are:

- Ultrasonic examination of welds in austenitic stainless steel
- Ferritic-austenitic (duplex) stainless steels
- Detection of corrosion and/or thickness measurement
- Phased array ultrasonic testing
- Automated Ultrasonic Testing, AUT
- For special application during in-service inspection
- Estimation of defect size (height) using conventional beam spread diagram (20 dB drop), Time-Of-Flight-Diffraction (TOFD) technique or the back diffraction technique
- Testing of objects with temperature outside the range 0°C to 40°C.

The ultrasonic testing procedure shall be submitted for acceptance.

305 No special procedure qualification test should be required when manual methods are used.

Ultrasonic testing techniques

306 Ultrasonic testing techniques shall be in accordance with ISO 17640 and DNV classification note 7, and

the requirements below.

Guidance note:

Manual or semi-automated ultrasonic phased array systems may be used provided it is qualified that such systems will give the same sensitivity, resolution and detection ability as conventional ultrasonic testing performed according to the requirements given in B300 and that specific ultrasonic testing procedures are developed and accepted.

---e-n-d---of---G-u-i-d-a-n-c-e---n-o-t-e---

Manual ultrasonic testing equipment

307 Manual ultrasonic testing equipment shall:

- be applicable for the pulse echo technique and for the double probe technique
- cover as a minimum the frequency range from 1 to 6 MHz
- have a calibrated gain regulator with maximum 2 dB per step over a range of at least 60 dB
- have a flat screen accessible from the front for direct plotting of reference curves or be equipped with digital DAC- display presentation of user-defined curves
- allow echoes with amplitudes of 5% of full screen height to be clearly detectable under test conditions.

308 Calibration of ultrasonic equipment shall be undertaken according to procedures established according to a recognised code or standard, e.g. EN 12668-1-2-3 or ASME V. Verification of Screen Height Linearity and Amplitude Linearity shall be performed at the beginning of each period of extended use (or every 3 months, whichever is less). Calibration records shall be made available upon request.

Semi-automated ultrasonic testing equipment

309 Semi-automated ultrasonic testing equipment shall follow the examination requirements of ASME V, Article 4, Mandatory Appendix VI.

Probes

310 Probes used for testing of welds with C-Mn steel weld deposits shall be characterised as required by ISO 10375 and ISO 12715.

Angle beam shear-wave probes shall be available in angles allowing effective testing of the actual weld connections. For testing of girth welds or welds in plate probe angles of 45°, 60° and 70° will normally be sufficient but additional probes of 35° and 55° are recommended. Other applications may require probes covering the range of 35° to 80° to allow effective testing.

Straight beam probes shall be single or twin crystal probes. Twin crystal probes shall be used when testing is performed on material with nominal thickness $t < 60$ mm. Single crystal probes may be used when testing is performed on material with nominal thickness $t \geq 60$ mm.

Probes shall, if necessary, be suitable for use on hot surfaces (100 to 150°C).

311 Additional probes for time-of-flight diffraction (ToFD) and double probe techniques are recommended.

312 Probe frequencies shall be selected according to ISO 17640.

Guidance note:

The nominal angle of probes used are normally valid for C-Mn steels with compression wave velocity of approximately 5900 m/s and shear wave velocity of approximately 3200 m/s at 20°C.

---e-n-d---of---G-u-i-d-a-n-c-e---n-o-t-e---

Coupling medium

313 The same coupling medium as used for calibration and setting of gains and amplification shall be used during testing.

Calibration of range scale and angle determination

314 The IIW or ISO calibration blocks (K1 – K2) according to ISO 2400 or ISO 7963 respectively, shall be used for calibration of range scale and for angle determination. These calibration blocks shall, as near as practicable, have the same acoustic properties as the material to be tested.

Reference blocks for setting of reference levels

315 For testing of welds reference blocks shall be used for gain calibration and construction of the reference curves. The reference block shall be manufactured from the actual material to be examined. Reference blocks manufactured from other materials may be acceptable provided that the material is documented to have acoustic properties similar to the actual material to be examined. The reference block shall have length and width dimensions suitable for the sound beam path for all probe types and the material dimension(s) to be tested.

For testing of welds in plate and similar geometries a reference block with side drilled holes shall be used. The thickness of the reference block, diameter and position of the drilled holes shall be as shown in Figure 1 and Table D-1.

For testing of welds in pipe when testing can be performed from one side only, and the DAC reference signals can only be obtained from the side where the inspection shall be performed, i.e. the D side, the reference blocks shall have side drilled holes at $T/4$, $T/2$ and $3/4T$.

When ultrasonic testing is to be performed on TMCP steel reference blocks shall, when required, be produced perpendicular to and/or parallel to the direction of rolling. The rolling direction shall be clearly identified.

316 For testing of longitudinal welds in pipe and similar geometries the reference block shall in addition to the features required above, have a curvature equal to the pipe to be tested.

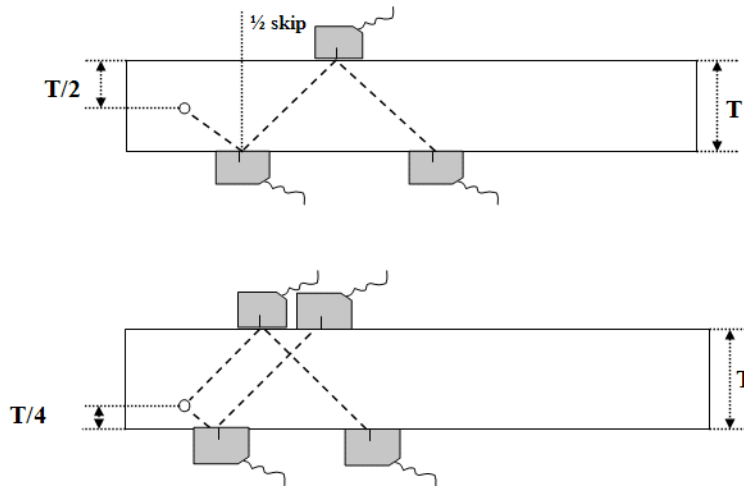

Figure 1
Reference block dimensions

Table D-1 Reference Block Dimensions				
<i>Material thickness (t)</i>	<i>Thickness of reference block (T)</i>	<i>Diameter of side drilled hole (mm)</i>	<i>Position of side drilled hole</i>	<i>Note</i>
$T < 15 \text{ mm}$	15 mm or t	2.4 ± 0.2	T/2	Additional holes are required for testing of pipe when the DAC can be constructed from one side only. Additional holes are generally allowed and recommended
$15 \text{ mm} \leq t < 35 \text{ mm}$	20 mm or t	3.0 ± 0.2		
$35 \text{ mm} \leq t < 50 \text{ mm}$	38 mm or t	3.0 ± 0.2	T/4	
$50 \text{ mm} \leq t < 100 \text{ mm}$	75 mm or t			
$100 \text{ mm} \leq t < 150 \text{ mm}$	125 mm or t			

317 All reference blocks shall be marked with an identification that relates to the specific application of each block

Gain calibration

318 The DAC- curve shall be constructed using reference blocks with side-drilled holes as described in 314.

319 Reference blocks not made from the actual material to be tested shall be checked for variation in acoustic properties between the reference block and the actual material. The variation can be checked by calibrating the range scale on the ISO 2400 block with a normal probe and subsequently measure a known material thickness with this calibration.

320 Whenever ultrasonic testing of welds in TMCP steel is performed, the difference in attenuation between transverse and longitudinal rolling direction shall be checked when the scanning direction changes between transverse and parallel to the rolling direction. This requires DAC constructed by use of calibration blocks taken from transverse and parallel to the rolling direction. Difference in gain setting must be noted and taken into consideration when evaluation of indications is performed.

321 When testing is carried out of welds in TMCP steel the actual beam angle shall be determined. The angle can be calculated using trigonometric functions as long as the distance and depth to the reflectors in the TMCP steel reference block is known. Alternatively the method described in App.E, subsection K can be used.

Construction of the reference curves (DAC)

322 The echo reflected from the drilled hole in the calibration block shall be maximised and the amplitude set at 80% of full screen height.

323 The first point of DAC must be selected such that the distance in sound path from the probe index to the drilled hole is not less than 0.6 N where N is the near field length of the relevant probe. The DAC shall be constructed by obtaining at least 3 points on the curve. The gain setting shall be recorded and comprises the primary gain.

The recorded gain following all corrections for surface condition and attenuation is the corrected primary gain. Alternatively, a Time Corrected Gain calibration can be used if the ultrasonic apparatus is fitted with a time corrected gain (TCG) correction. The echo amplitude reflected from the drilled hole in the calibration can be adjusted to 80% of full screen height over the whole range in question. DAC will thus be a horizontal line.

Periodical checks of equipment, re-calibration and re-examination

324 At approximately four-hourly intervals and at the end of testing, the range scale, probe angle and primary gain must be checked and confirmed.

If deviation is found to be larger than 2% of range scale, or 4 dB of primary gain setting or 2° of nominal probe angle, the equipment shall be re-calibrated and the testing carried out with the equipment over the previous period shall be repeated.

Re-calibration shall be performed whenever the equipment has been out function for any reason including on-off and whenever there is any doubt concerning proper function of the equipment.

Contact surface

325 For ultrasonic testing the contact surface shall be clean and smooth, i.e. free from dirt, scale, rust, welding spatter, etc. which may influence the result of the testing. Correction for differences in surface conditions and attenuation between the reference block and the actual work piece shall be performed and the maximum correction allowed on flat surfaces is 6 dB.

Testing levels

326 The testing level shall be in accordance with ISO 17640, chapter 11, testing level B and the requirements below.

Probe selection

327 In addition to straight beam probe minimum two angle probes shall be used for the testing, see the guidance given in Table D-2. It is emphasised that this table is for guidance and that the actual choice of angle probes must be made carefully and depending on material thickness, weld bevel and type of defects likely to occur with the welding method used.

Table D-2 Parent material thickness and related Probe angle	
<i>Parent material thickness, T</i>	<i>Probe angle</i>
15 to 40 mm	45° and 60° or 70° (70° when ½ V or K groove)
T > 40 mm	45° and 60° or 70° (70° when ½ V or K groove)
15 to 40 mm	45° and 60° or 70° (70° when ½ V or K groove)

328 The choice of optimum probe angle for initial full scanning of the weld shall be chosen such that incident angle of the sound beam centre is perpendicular to the side of the weld bevel. If this angle does not comply with any standard probe angle, the nearest larger probe angle shall be selected.

329 In addition to the probe used for initial scanning two additional angle probes shall be used when possible.

330 These additional probes shall have a larger and smaller angle than the probe used for initial scanning. The differences in angle shall be more than 10°.

331 If only one additional probe can be used the angle for this probe should be:

- $\geq 10^\circ$ different
- Larger than the initial probe if the sound beam centre of the initial probe is perpendicular to the side of the weld bevel
- Smaller than the initial probe if the nearest larger probe angle was selected for the initial probe

Testing of welds

332 When scanning, the gain shall be increased by a minimum of 6 dB above the corrected primary gain. Testing of welds shall be performed in accordance with ISO 17640.

333 The scanning zone for angle probes in the base material shall be examined with straight beam (normal) probes for features that might influence the angle beam testing. The scanning zone is defined as $1.5 \times$ full skip distance. Features interfering with the scanning shall be reported.

334 The welds shall whenever feasible be tested from both sides on the same surface and include scanning for both transverse and longitudinal indications. For T-joints and plate thickness above 70 mm, scanning from both surfaces and all accessible sides shall be performed.

Evaluation of indications

335 For evaluation of indications the gain shall be reduced by the increased dB level used during scanning.

336 All indications equal to or exceeding 33% of the reference curve (evaluation level) shall be evaluated. The indications shall be investigated by maximising the echoes by rotating the probes and by using different angle probes with DAC established according to 321 and 322.

337 The length of an indication shall be determined by measuring the distance between the points where the echo amplitude exceeds the evaluation level using the fixed level technique.

338 The final evaluation against the acceptance criteria shall be based on the echo amplitude and length measured with the probe angle giving the maximum response.

Reporting

339 Reports shall be in accordance with B105 and B106. In addition to the items listed in ISO 17640 the following shall be included in the ultrasonic testing report:

- identification of the ultrasonic testing procedure used
- the length of acceptable indications with amplitude exceeding 50% of the reference curve.

B 400 Manual ultrasonic testing of welds with CRA (duplex, other stainless steels and nickel alloy steel) weld deposits

General

401 Ultrasonic testing shall be performed in compliance with B300, ISO 22825, ISO 17640, and as required below.

402 Weld deposits in duplex, austenitic stainless steels and nickel alloys have a coarse grain structure with variations in grain size and structure resulting in unpredictable fluctuations in attenuation and ultrasonic beam patterns. Duplex and austenitic stainless steel base materials, in particular forgings and castings, will have the same characteristics.

Ultrasonic testing of welds with CRA (duplex, other stainless steels and nickel alloy steel) weld deposits will in order to achieve an adequate detection of imperfections require that special calibration blocks and probes are used for testing of welds in these materials. Angle probes generating compression waves shall be used, but alternative waveforms may be employed providing procedure techniques have been demonstrated and provide equivalent detection capabilities.

Ultrasonic testing procedures

403 Specific ultrasonic testing procedures shall be developed for this testing in compliance with this chapter and including the information required in B102 and B303. The procedure shall be submitted for acceptance prior to start of testing.

Personnel qualifications

404 In addition to the requirements given in A500 personnel performing testing of welds with duplex, other stainless steels and nickel alloy steel weld deposits shall be qualified for or document adequate experience and training for this type of ultrasonic testing.

Manual ultrasonic testing equipment

405 The requirements given in B307 and B308 shall apply

Probes

406 In addition to the requirements given in B309, B310 and B311, the requirements below shall apply.

407 Probes used for testing should be straight beam transducers and twin crystal (transmitter/receiver) compression wave probes of 45°, 60° and 70°. In addition similar shear-wave angle probes shall be used, if found suitable.

408 In general, using a combination of shear and compression wave angle probes is recommended since the detection of “open to surface” imperfections on the opposite surface of the scanning surface, e.g. incomplete penetration or lack of fusion, may increase by using shear wave probes. It must, however, be verified by using calibration blocks with actual weld connections, see 418 below, that angle shear wave probes are suitable.

409 Creep wave probes shall be used for detection of sub surface defects close to the scanning surface, unless testing can be performed from opposite sides.

Reference blocks for setting of reference levels

410 In addition to the reference blocks as described in B315, B316 and B317, reference blocks prepared from the actual test material and containing welds produced in accordance with the actual WPS shall be used for establishing the DAC. These reference blocks shall have the weld ground flush and the surface condition of the calibration blocks shall be typical of the condition of the parent material(s) in the scanning areas.

411 The reference block for construction of DAC shall have side drilled holes with dimensions according to Table D-3 and located as shown in Figure 2. The length and width of the reference blocks shall be sufficient to

allow the scanning needed for construction of the DAC.

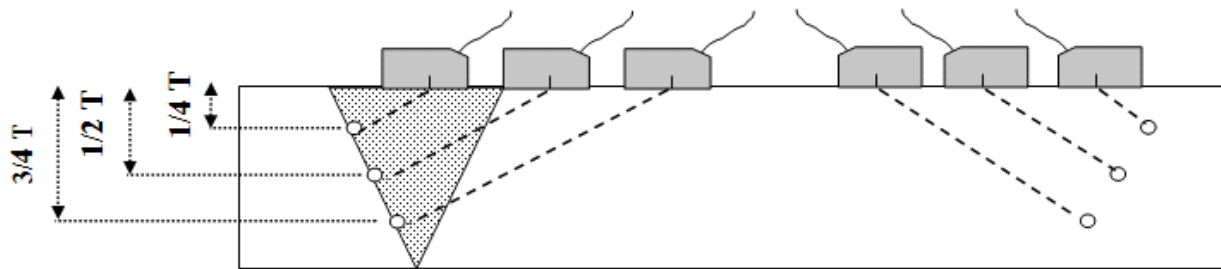

Figure 2
Reference block for construction of DAC, dimensions

Notes:

- 1) Side drilled holes shall be drilled in the fusion line and in the base material. Holes in the base material shall be in the same relative position as the fusion line holes.
- 2) Holes shall be drilled in both fusion lines and base material when two dissimilar materials are welded to each other.
- 3) For double sided welds, side drilled holes shall be located in the fusion line for the full thickness of the weld.
- 4) For hole positions when $t \geq 50$ mm, see Table D-3.

Table D-3 Reference Block Dimensions			
<i>Material thickness (t)</i>	<i>Thickness of reference block (T) in</i>	<i>Diameter of side drilled hole in mm</i>	<i>Position of side drilled holes.</i>
$T < 15$ mm	15 mm or t	2.4 ± 0.2	T/4, T/2 and T3/4
$15 \text{ mm} \leq t < 35$ mm	25 mm or t	3.0 ± 0.2	
$35 \text{ mm} \leq t < 50$ mm	45 mm or t		
$50 \text{ mm} \leq t < 100$ mm	75 mm or t	3.0 ± 0.2	The distance between the two outer holes and the nearest surface shall not exceed 12 mm.
$100 \text{ mm} \leq t < 150$ mm	125 mm or t		

412 The reference block for sensitivity setting for creep wave probes shall have 0.5, 1.0 and 2.0 mm spark eroded notches with a minimum length of 20 mm as shown in Figure 3. The location of notches shall allow setting against each individual notch.

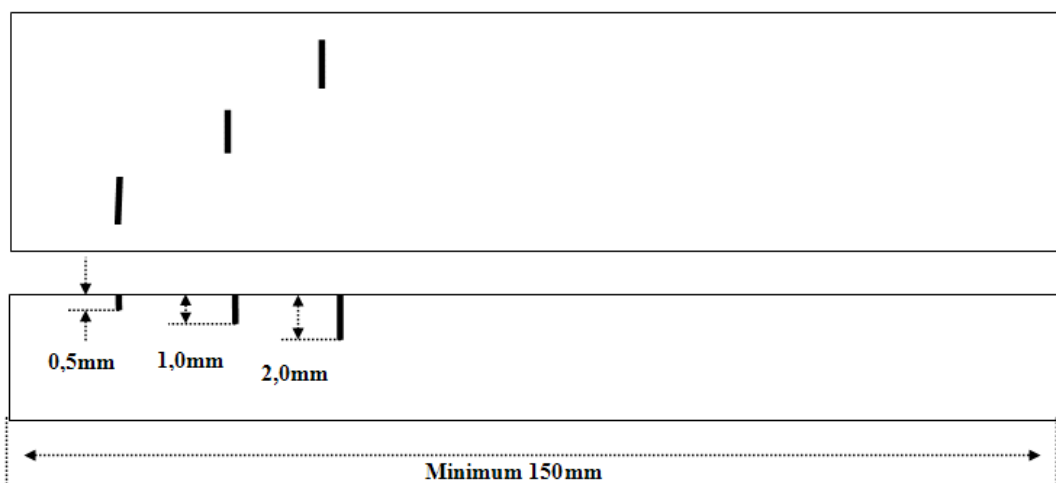

Figure 3
Reference block for sensitivity setting for creep wave probes, dimensions

Construction of the reference curves (DAC) for angle compression wave probes

413 Angle compression wave probes shall and can only be used for scanning without skipping. The construction of the DAC curves using angle compression wave probe shall be performed according to:

- when the ultrasonic beam is passing through the parent metal only
- when ultrasonic beam is passing through the weld metal.

414 When the ultrasonic beam is passing through the parent metal only the DAC curve shall be constructed from the drilled holes in the parent material of the calibration blocks, see Figure 2. Next, a maximum response shall be obtained from the holes in the weld fusion line and if necessary, the gain setting shall be adjusted such that this response reach the DAC constructed against drilled holes in the parent material. This shall be the primary gain to be used when locating indications on the fusion line on the side of the weld nearest to the scanning side.

415 When the ultrasonic beam is passing through the weld metal, the DAC curve shall be constructed from the holes drilled in the fusion line on the side of the weld opposite to the scanning side. See Figure 2. This DAC shall be verified against the holes drilled in the base material. Any variations must be noted so that echoes reflected from indications within the weld zone can be evaluated for amplitude response.

Transfer correction

416 Since compression wave angle probes can only be used without skipping, transfer correction can not be performed. The calibration blocks must therefore have a surface finish similar to the production material.

Sensitivity setting for creep wave probes

417 The reference block shown in Figure 3 shall be used for sensitivity setting for creep wave probes. The echo response from the 1.0 mm notch shall be set to 75% of FSH.

Shear wave angle probes

418 If shear wave angle probes are considered for skipped scanning or in the root area of single sided welds, it must be verified on the reference blocks with welds, see Figure 2, if it is possible to obtain a DAC with a shear wave angle probe that is comparable to the DAC obtained with an angle compression wave probe.

Preparation of weld and scanning surfaces for testing

419 Prior to starting the testing the external weld cap shall be ground flush with the adjacent base material. The surface finish of the weld and the scanning areas shall be as that on the reference blocks to be used or better.

Probe selection

420 In addition to the straight beam probe minimum two angle probes shall be used for the testing, see the guidance given in Table D-2 and B327 through B331.

421 Where the weld configuration or adjacent parts of the object are such that scanning from both sides is not possible, two additional probes shall always be used.

B 500 Manual magnetic particle testing of welds

General

501 Magnetic particle testing shall be performed in compliance with ISO 17638 and as required below.

502 Magnetic particle testing shall be performed according to accepted procedures.

Magnetic particle testing procedures

503 Magnetic particle testing procedures shall be according to B102 through B104 and include:

- type of magnetisation
- type of equipment
- surface preparation
- wet or dry method
- make and type of magnetic particles and contrast paint
- magnetising current (for prod magnetising, the prod type and spacing shall be stated)
- demagnetisation
- description of the testing technique.

504 No special procedure qualification tests is required.

Magnetising equipment

505 The equipment shall be tested at maximum 6 months interval to verify that the required field strength is established at the maximum pole distance/prod spacing to be used. The results shall be recorded.

506 Prods shall be soft tipped with lead or similar. Sparks between the prods and the material tested shall be avoided.

507 Electromagnetic AC yokes shall develop a minimum lifting force of 4.5 kg at maximum pole distance on a block with equivalent magnetic properties as the object to be tested. The lifting force shall be checked prior to start of any testing and at regular intervals during testing.

508 Use of permanent magnets and DC yokes may only be used for specific applications if required by national regulations and subject to agreement.

Application techniques

509 Magnetic particle testing shall not be performed on parts with surface temperatures exceeding 300°C. Between 60°C and 300°C, only dry magnetic particle testing shall be used.

Detection media

510 For both wet or dry particles, they shall provide adequate contrast with the background or the surface being tested.

Viewing conditions

511 Testing with fluorescent magnetic particles shall be conducted in a darkened area with maximum 20 lux background light, using filtered ultraviolet light with wave lengths in the range of 3200 to 3900 Å. The minimum UV light intensity shall be 1000 $\mu\text{W}/\text{cm}^2$. Operators/interpreters shall allow sufficient time for eyesight to adjust to the dark surroundings. Interpreters shall not wear photo-chromatic viewing aids.

For color contrast technique, the minimum viewing conditions shall be 1000 lx white light at the area of interest.

Reporting

512 Reports shall be in accordance with B105 and B106. In addition to the items listed in ISO 17638 the following shall be included in the testing report:

— Identification of the testing procedure used.

B 600 Manual liquid penetrant testing of welds

General

601 Liquid penetrant testing shall be performed in compliance with ISO 3452 and as required below

602 Liquid penetrant testing should only be used on non-ferromagnetic materials or materials with great variation in magnetic permeability.

603 Liquid penetrant testing shall be performed according to accepted procedures. Viewing conditions shall be minimum 1000 lx at the area of interest.

Procedures

604 Liquid penetrant testing procedures shall be according to B102 through B104 and include:

- surface preparation
- make and type of penetrant, remover, emulsifier and developer
- details of pre-testing cleaning and drying, including materials used and time allowed for drying
- details of penetrant application: the time the penetrant remains on the surface, the temperature of the surface and penetrant during the testing (if not within the 15°C to 35°C range)
- details of developer application, and developing time before evaluation
- method for post-test cleaning.

Application techniques

605 The penetration and developing times shall be long enough to allow effective detection of the smallest indications allowed. The penetration time shall comply with the manufacturers recommendation, minimum 15 minutes. Development time should be at least equal to the penetration time. The inspection area shall be monitored during developing time. Demonstration of adequate detection shall be performed for short penetration times.

606 When the temperature of the surface and the penetrant is within the range 15°C to 35°C, no special procedure qualification tests should be required.

Outside the temperature range 10°C to 50°C, the procedure shall be qualified and a suitable comparator block shall be used to compare indications from surface defects tested within and outside the range during the procedure qualification.

Reporting

607 Reports shall be in accordance with B105 and B106.

B 700 Manual eddy current testing of welds

General

701 Eddy current testing shall be performed in compliance with ISO 17643. The limitations given in ISO 17643, paragraph 6.3, notes 1 and 2 shall apply.

702 Eddy current testing shall be performed according to accepted procedures.

Procedure

703 Eddy current testing procedures shall contain the information in B102 and:

- type of instrument
- type of probe
- frequency setting
- calibration blocks and calibration details
- surface condition requirements
- scanning details
- recording details.

Equipment

704 Eddy current equipment, including probes and cables, shall be calibrated at maximum 6 months intervals and shall have calibration certification pertaining to the characteristics of the equipment.

705 Functional checks of the eddy current equipment shall be carried out whenever it has been out of function for any reason including on/off, and whenever there is any doubt concerning proper functioning of the equipment.

706 All calibration blocks shall be marked with an identification that relates to the specific application of each block.

Surface conditions

707 Excess weld spatter, scale, rust and loose paint shall be removed before the inspection.

Application techniques

708 ISO 17643 shall apply.

Reporting

709 Reports shall be in accordance with B105 and B106. In addition to the items listed in ISO 17643 the following shall be included in the testing report:

- Identification of the testing procedure used.

B 800 Visual examination of welds

General

801 Visual examination of welds shall be performed in accordance with ISO 17637 and accepted procedures.

802 Reports shall be in accordance with ISO 17637. In addition to the items listed in ISO 17637 the following shall be included in the testing report:

- Identification of the testing procedure used.

B 900 Acceptance criteria for manual non-destructive testing of welds with nominal strains < 0.4% and no ECA

General

901 The acceptance criteria given in Table D-4, Table D-5, Table D-6 and Table D-7 are applicable for non-destructive testing of welds exposed to nominal strains < 0.4%.

902 The acceptance criteria use the term defect to define an imperfection/indication that has exceeded given dimensions and thus is deemed unacceptable.

903 The acceptance criteria given in Table D-5 assume that multi-pass welds are used and that the height of defects will not exceed 0.25 t or the height of a welding pass. The height of the welding pass shall be assumed not to be more than 3 mm. If welding methods resulting in higher welding passes are used (SAW, “one-shot” welding etc.), flaw indications equal or larger than the length limits given in the tables shall be height determined with ultrasonic testing. If the height exceeds 0.2 t, the defect is not acceptable unless proven to meet the acceptance criteria for ultrasonic testing in Table D-6.

Pipeline girth welds

904 The acceptance criteria given in Table D-4, Table D-5 and Table D-6 are generally applicable for manual non-destructive testing of pipeline girth welds exposed to total nominal strains < 0.4%.

905 Acceptance criteria applicable for automated ultrasonic testing (AUT) of pipeline girth welds exposed to total nominal strains < 0.4% are given in Appendix E.

906 If the allowable defect sizes are established by an ECA for pipeline girth welds exposed to total nominal strains $\geq 0.4\%$, the provisions according to B1000 shall apply.

Welds in pipeline components

907 The acceptance criteria given in Table D-4, Table D-5 and Table D-6 are generally applicable for manual non-destructive testing of welds in pipeline components. For girth welds connecting a component to the pipeline or for pup-pieces welded to the component, the acceptance criteria for pipeline girth welds shall apply, unless other acceptance criteria are given in the design, manufacture and testing data for the component.

908 For welds exposed to total nominal strains $\geq 0.4\%$, the allowable defect sizes shall be established by an ECA and the provisions according to B1000 shall apply.

B 1000 ECA based non-destructive testing acceptance criteria for pipeline girth welds

General

1001 Acceptance criteria for pipeline girth welds can be based on an Engineering Critical Assessment (ECA).

1002 Whenever acceptance criteria for NDT are established by an ECA, the ECA shall be performed in accordance with the requirements given in Appendix A.

1003 If acceptance criteria for weld defects are based on an ECA and hence involves sizing of indication height and lengths, manual ultrasonic testing or automated ultrasonic testing shall be performed.

1004 Sizing of indication height and length by manual or automated ultrasonic testing will have inherent inaccuracies. The allowable defect sizes derived from an ECA must accordingly be corrected for the ultrasonic testing uncertainty (sizing error) as follows:

- If the ECA gives the allowable defect size the sizing error shall be subtracted from the calculated allowable defect height and length to establish the acceptance criteria for non-destructive testing.
- If the ECA gives the material properties and stresses/strains allowed to tolerate a given defect size the sizing error shall be added to the defect height and length used as input into the ECA to establish the acceptance criteria for non-destructive testing.

1005 If an embedded defect is located close to a surface, such that the ligament height is less than half the defect height, the ligament height between the defect and the surface shall be included in the defect height.

Automated ultrasonic testing uncertainty data

1006 If automated ultrasonic testing (AUT) is used for testing of pipeline girth welds, the uncertainty data used shall be obtained from the qualification testing of the automated ultrasonic testing system required in Appendix E.

Manual ultrasonic testing uncertainty data

1007 For manual ultrasonic testing the data used for quantitative estimates of uncertainty performance and reliability in the sizing of indication length and height, shall preferably be of the “measured response versus actual flaw size” type. The estimates shall be based on published results from comprehensive studies into the reliability of manual ultrasonic testing.

1008 If adequate data for manual ultrasonic testing are not available, the sizing error shall not be taken as less than 2.5 mm.

Acceptance criteria based on ECA assessment

1009 Appendix A gives requirements for establishing allowable defect sizes based on an ECA assessment.

1010 Acceptance criteria shall be established by correcting the allowable defect sizes derived from the ECA with the ultrasonic testing uncertainty in accordance with 1005 or 1006 and 1007.

Guidance note:

Acceptance criteria based on ECA will frequently allow significantly larger indications than workmanship based acceptance criteria. In order to maintain a high standard of welding ECA based allowable defect sizes may be used as a weld repair criterion rather than as acceptance criterion. Criteria that are more restrictive are then used as a measure of the welding standard obtained. If these more restrictive criteria are exceeded, it should be required that preventative or corrective actions are performed to maintain the required welding standard.

---e-n-d---of---G-u-i-d-a-n-c-e---n-o-t-e---

Table D-4 Acceptance criteria for visual examination and surface method testing of welds ^{1) 2)}			
<i>Visual examination</i>			
External profile (not relevant for SAWL in pipe mills)	Welds shall have a regular finish and merge smoothly into the base material and shall not extend beyond the original joint preparation by more than 3 mm (5 mm for SAW welds). Fillet welds shall be of specified dimensions and regular in form.		
Cap and root reinforcement height (Longitudinal welds)	External welds: For $t < 13$ mm: max. 3.0 mm. For $t \geq 13$ mm: max. 4.0 mm Internal welds: max. 3.5 mm	The radial offset of HFW linepipe shall not reduce the thickness to weld to less than t_{min} .	
Weld flash (HFW pipe longitudinal welds only)	The external flash shall be trimmed essentially flush with the pipe surface, with no noticeable radial step. The internal flash shall not extend above the contour of the pipe by more than $0.3 \text{ mm} + 0.05 t$. The trimming shall not reduce the wall thickness to below t_{min} , and the groove resulting from the trimming shall have a smooth transition to the base material without notches and the depth shall be max. $0.05 t$. (see ISO 3183 Table 15)		
Cap and root reinforcement height (Double sided girth welds)	Height $< 0.2 t$, but max. 4.0 mm		
Cap reinforcement (Single sided welds)	Height $< 0.2 t$, but max. 4.0 mm		
Root penetration (Single sided welds)	Height $< 0.2 t$, but max. 3.0 mm. Length of excess penetration: max 25 mm		
Weld interpenetration (double-sided SAW in pipe mills)	Option 1) minimum 1.0 mm overlap in the radial direction Option 2) Width of overlap to be measured with a straight line perpendicular to the radial direction. The length shall be minimum 20% of nominal WT or 5 mm, whichever is less.		
Cap concavity	Not permitted.		
Root concavity	At no point shall the weld thickness be less than t_{min}		
Offset of strip/plate edges (Longitudinal welds)	For $t \leq 15$ mm max. 1.3 mm For $15 \text{ mm} < t \leq 25$ mm max. $0.1 t$ For $t > 25$ mm max. 2.0 mm	For welds in clad/lined material the offset shall not reduce the effective thickness of the cladding/lining in the root area	
High/low on root side of single sided girth welds	For $t \leq 13$ mm max. 1.3 mm For $13 \text{ mm} < t \leq 20$ mm max. $0.1 t$ For $t > 20$ mm max. 2.0 mm	For welds in clad/lined material the offset shall not reduce the effective thickness of the cladding/lining in the root area	
Transverse misalignment of weld beads for double sided welds	max. 3.0 mm for $t \leq 20$ mm max. 4.0 mm for $t > 20$ mm		
Deviation of weld toe from a straight line (double-sided SAW in pipe mills)	The weld toe shall run parallel to the weld longitudinal axis. The maximum deviation within any section of 300 mm length is $0.20 t$, but not more than 4.0 mm. A straight line shall be oriented parallel to the longitudinal axis of the weld (e.g. the longitudinal axis of the pipe). The distance from this line to the weld toe shall be determined, and the difference between the point closest and farthest from the line shall not exceed the acceptance criteria. (COMMENT: the intention is to determine the presence of both waving bead/dog-leg and widening/narrowing of the weld cap - both of which indicates unstable welding process. This should not be a reason to reject the pipe, since the cap can be ground. But an inspector shall be informed before any grinding, and measures to improve the welding practice shall be implemented)		
Undercut	Individual undercuts		
	Depth d	Permitted length	
	$d > 1.0$ mm	Not permitted	Accumulated length of undercuts in any 300 mm length of weld: None
	$1.0 \text{ mm} \geq d > 0.5$ mm	50 mm	$< 4 t$, max. 100 mm.
	$0.5 \text{ mm} \geq d > 0.2$ mm	100 mm	
$d < 0.2$ mm	unlimited	unlimited	
Cracks, Arc burns, Start/stop craters/poor restart, Surface porosity	Not permitted.		
Lack of penetration/lack of fusion	Not permitted for welds in duplex stainless steel, CRAs and clad/lined steel Individual acceptable length: t , max. 25 mm. Accumulated length in any 300 mm length of weld: t , max. 50 mm.		

Table D-4 Acceptance criteria for visual examination and surface method testing of welds 1) 2) (Continued)				
<i>Visual examination</i>				
Systematic imperfections	Imperfections that are distributed at regular distances over the length of the weld are not permitted even if the size of any single imperfection meets the requirements above			
Burn through	Not permitted for welds in duplex stainless steel, CRAs and clad/lined steel. Acceptable for welds in C-Mn and low alloy steels provided that weld thickness at no point is less than t and: — Individual length/width: t/4, max. 4 mm in any dimension. — Accumulated length in any 300 mm length of weld: t/2, max. 8 mm.			
<i>Surface testing (MT, PT and ET)</i>				
Wall thickness mm	Type of indications			
	Rounded		Linear	
	Number	Dimension mm	Number	Dimension mm
≤ 16	2	4.0	2	2.0
> 16	2	4.0	2	2.0
Notes:				
1) Any two imperfections separated by a distance smaller than the major dimension of the smaller imperfection shall be considered as a single imperfection.				
2) Detectable imperfections are not permitted in any intersection of welds.				

Table D-5 Acceptance criteria for radiographic testing of welds		
<i>Type of defect</i>	<i>Acceptance criteria 1) 2) 3) 10) 11)</i>	
	<i>Individual discontinuities</i>	<i>Maximum accumulated size of in any 300 mm weld length for each type of discontinuity</i>
Porosity ^{1) 2)} Scattered Cluster ⁵⁾ Wormhole Hollow bead Isolated ⁶⁾ On-line ⁷⁾	Diameter: < t/4, but max. 3 mm Individual pore: < 2 mm, cluster diameter max. 12 mm Length: t/2, but max. 12 mm, Width: t/10, but max. 3 mm Length: t, but max. 25 mm, Width: max. 1.5 mm Diameter: < t/4, max 3 mm Diameter: < 2 mm group length: 2t, but max. 50 mm	See Note 4 One cluster or total length < 12 mm 2 wormholes or total length < 12 mm Length 2 t, but max. 50 mm - Length 2 t, but max. 50 mm
Slag ^{1) 2) 3) 8)} Isolated Single lines Parallel lines	Width < 3 mm Width: max 1.5 Individual width: max 1.5	Length 12 mm, but max. 4 off separated by min 50 mm Length 2 t, but max. 50 mm Length 2 t, but max. 25 mm
Inclusions Tungsten Copper, wire	Diameter < 0.5 t, but max. 3 mm Not permitted	Max 2 off separated by min 50 mm -
Lack of penetration ^{1) 2) 3) 8)} Root Embedded ⁹⁾	Not permitted for welds in duplex stainless steel, CRAs and clad/lined steel Length: t, but max. 25 mm Length: 2t, but max. 50 mm	- Length t, but max. 25 mm Length 2 t, but max. 50 mm
Lack of fusion ^{1) 2) 3) 8)} Surface Embedded	Not permitted for welds in duplex stainless steel, CRAs and clad/lined steel Length: t, but max. 25 mm Length: 2 t, but max. 50 mm	- Length t, but max. 25 mm Length 2 t, but max. 50 mm
Cracks	Not permitted	-
Shrinkage cavities and crater pipes	Not permitted	-

Table D-5 Acceptance criteria for radiographic testing of welds (Continued)		
<i>Type of defect</i>	<i>Acceptance criteria</i> ^{1) 2) 3) 10) 11)}	
	<i>Individual discontinuities</i>	<i>Maximum accumulated size of in any 300 mm weld length for each type of discontinuity</i>
Root concavity	Length: 2t, but max. 50 mm	Length: 2 t, but max. 50 mm
Root undercut Excess penetration Burn through	See Table D-6	See Table D-4
Total accumulation of discontinuities (excluding porosity) <ul style="list-style-type: none"> — Maximum accumulation of discontinuities in any 300 mm weld length 3 t, max 100 mm. — Maximum accumulation of discontinuities: 12% of total weld length. — Any accumulation of discontinuities in any cross sections of weld that may constitute a leak path or may reduce the effective weld thickness with more than t/3 is not acceptable. 		
Notes: <ol style="list-style-type: none"> 1) Refer to the additional requirements in B903 for welding methods that produce welding passes exceeding 0.25 t. 2) Volumetric imperfections separated by less than the length of the smallest defect or defect group shall be considered as one imperfection. 3) Elongated imperfection situated in a line and separated by less than the length of the shortest defect shall be considered as one imperfection. 4) For single layer welds: 1.5% of projected area, for multi layer welds with t < 15 mm 2% of projected area, for multi layer welds with t ≥ 15 mm 3% of projected area. 5) Maximum 10% porosity in cluster area. 6) “Isolated” pores are separated by more than 5 times the diameter of the largest pore. 7) Pores are “In a line” if not “Isolated” and if 4 or more pores are touched by a line drawn through the outer pores and parallel to the weld. “On-line” pores shall be checked by ultrasonic testing. If ultrasonic testing indicates a continuous defect, the criteria for lack of fusion defect shall apply. 8) Detectable imperfections are not permitted in any intersection of welds. 9) Applicable to double sided welding where the root is within the middle t/3 only. 10) Acceptance criteria of Table D-4 shall also be satisfied. 11) Systematic imperfections that are distributed at regular distances over the length of the weld are not permitted even if the size of any single imperfection meets the requirements above. 		

Table D-6 Acceptance criteria for manual ultrasonic testing of welds 1) 2) 3) 4) 5) 6) 7)			
<i>Base material thickness $8\text{ mm} \leq t < 15\text{ mm}$</i>		<i>Base material thickness $15\text{ mm} \leq t \leq 150\text{ mm}$</i>	
<i>Max. echo amplitude</i>	<i>Corresponding acceptable indication length, L (mm)</i>	<i>Max. echo amplitude</i>	<i>Corresponding acceptable indication length, L (mm)</i>
Reference level (DAC)	$L \leq t$ (but max. 8 mm)	DAC + 4 dB	$L \leq 0.5t$ (but max. 12.5 mm)
DAC – 6 dB	$L > t$ (but max. 8 mm)	DAC – 2 dB	$0.5t < L \leq t$ (but max. 25 mm)
-	-	DAC – 6 dB	$L > t$ (but max. 25 mm in both outer t/3)
-	-	DAC – 6 dB	$L > t$ (but max. 50 mm in middle t/3)
Cracks are not permitted.			
<i>For welds in duplex stainless steel, CRAs and clad/lined steel:</i> Lack of fusion and lack of penetration are not permitted.			
<i>Transverse indications:</i> Indications shall be considered as transverse if the echo amplitude transversely exceeds the echo amplitude from the same indication longitudinally with more than 2 dB. Transverse indications are unacceptable unless proven not to be planar, in which case the acceptance criteria for longitudinal indications apply.			
<i>For indications approaching the maximum permitted length:</i> It shall be confirmed that the indication height is less than 0.2 t or maximum 3 mm (see B903). If an embedded defect is located close to a surface, such that the ligament height is less than half the defect height, the ligament height between the defect and the surface shall be included in the defect height.			
<i>Total accumulation of discontinuities:</i> The total length of acceptable indications with echo amplitude of reference level – 6 dB and above shall not exceed 3 t, maximum 100 mm in any weld length of 300 mm nor more than 12% of total weld length. Any accumulation of defects in any cross section of weld that may constitute a leak path or reduce the effective thickness of weld more than t/3 is not acceptable.			
If only one side of the weld is accessible for testing 6 dB shall be subtracted from the maximum echo permitted above.			
Notes:			
<ol style="list-style-type: none"> 1) Reference level is defined as the echo amplitude corresponding to the echo from the reflector in the reference blocks described in Figure 1, Figure 2 and Figure 3 of this appendix, or equivalent reflector. 2) All indications exceeding 20% of the reference level shall be investigated to the extent that the operator determines the shape, length and location of the imperfection. 3) Indications that cannot be established with certainty shall whenever possible be tested with radiography. Indications that are type determined in this way shall meet the acceptance criteria in Table D-5. 4) Longitudinal imperfections where the echo height intermittently is below and above the acceptance level shall if possible be investigated with radiography. Indications that are determined in this way shall meet the acceptance criteria in Table D-5. If radiography cannot be performed, the length shall not exceed 3 t, maximum 100 mm in any weld length of 300 mm. 5) Length and depth shall be determined by an appropriate method, see B335 and B336. 6) Detectable imperfections are not permitted in any intersection of welds. 7) Systematic imperfections that are distributed at regular distances over the length of the weld are not permitted even if the size of any single imperfection meets the requirements above. 			

B 1100 Repair of welds

1101 A repaired weld should be subject to the same testing requirements and acceptance criteria as the original weld.

1102 In cases when the acceptance criteria are based on an ECA, specific acceptance criteria for repair welds shall be established by an ECA based on the fracture toughness properties obtained during qualification of the repair welding procedure.

1103 Repair welding of cracks is not permitted unless the cause of cracking has been established not to be a systematic welding error. (If there is a crack in the weld, the weld is per definition considered rejected. This means a technical evaluation of the cause of cracking shall be performed. If it can be demonstrated that the crack is a “one off” situation, then repair welding may be performed subject to agreement).

C. Manual Non-destructive testing and Visual Examination of Plate, Pipe and Weld Overlay

C 100 General

101 All non-destructive testing, visual inspection of plate, pipe and weld overlay shall be according to accepted procedures. Note that the requirements of C200 are not applicable to plate or pipe mills, see 201.

102 Manual non-destructive testing and visual examination procedures shall be prepared as required in B102 through B104 to reflect the requirements of the applied standard.

103 Acceptance criteria for manual non-destructive testing and visual examination of plate, pipe and weld overlay are given in C600.

104 Manual non-destructive testing of plate, pipe and weld overlay shall be performed in compliance with the standards listed below and as required in the following:

ISO 10893-8	Non-destructive testing of steel tubes - Part 8: Automated ultrasonic testing of seamless and welded steel tubes for the detection of laminar imperfections, App.A.
ISO10893-9	Non-destructive testing of steel tubes - Part 9: Automated ultrasonic testing for the detection of laminar imperfections in strip/plate used for the manufacture of welded steel tubes.
ASTM E165	Standard Test method for Liquid Penetrant Inspection
ASTM E309	Standard Practice for Eddy-Current Examination of Steel Tubular products Using Magnetic Saturation
ASTM E426	Standard Practice for Electromagnetic (Eddy Current) of Welded and Seamless Tubular Products, Austenitic Stainless Steel and Similar Alloys
ASTM A578/578	Standard Specification for Straight-Beam Ultrasonic Examination of Plain and Clad Steel Plates for Special Applications
ASTM A577/577	Standard specification for Ultrasonic Angle-Beam Examination of Steel Plates
ISO 9934	all parts; Non-destructive testing - Magnetic particle testing
ISO 3452	all parts; Non-destructive testing - Penetrant testing.

C 200 Plate and pipe

General

201 These requirements are not applicable for plate and coil examined at the plate/coil mill as covered by subsection G, or for linepipe examined at the pipe mill as covered by subsection H.

General requirements for ultrasonic testing

202 Ultrasonic equipment shall meet the requirements given in B307 and B308.

203 Probes used for testing of pipe and plate shall be characterised as required by ISO 10375 and ISO 12715.

Angle shear-wave probes of 45° and 60° shall be used for C-Mn and low alloy steels. Angle probes for duplex stainless steel and austenitic steels shall be twin crystal (transmitter/receiver) compression-wave probes of 45° and 60°. Angle compression wave probes shall and can only be used for scanning without skipping.

Straight beam probes shall be single or twin crystal. Twin crystal probes shall be used when testing is performed on material with nominal thickness $t < 60$ mm. The focusing zone of the twin crystal probes shall be adapted to the material thickness to be examined.

Single or twin crystal probes can be used when testing is performed on material with nominal thickness $t \geq 60$ mm. The single crystal probes shall have a dead zone as small as possible, e.g. 10% of the material thickness or 15 mm whichever is the smaller. Selected probes shall have a nominal frequency in the range of 2 MHz to 5 MHz and dimensions $\varnothing 10$ mm to $\varnothing 25$ mm.

204 The IIW or ISO calibration blocks (K1 – K2) according to ISO 2400 or ISO 7963 shall be used for calibration of range scale and for angle determination. These calibration blocks shall, as near as practicable, have the same acoustic properties as the material to be tested.

Manual ultrasonic thickness measurements

205 Manual ultrasonic thickness measurements shall be done in accordance with ASTM E797 or equivalent standard.

Ultrasonic testing for detection of laminar flaws

206 Manual ultrasonic testing for detection of laminar flaws in steel other than clad/lined steel shall be performed according to ISO 10893-8 App.A, ISO 10893-9 App.A or equivalent standard.

207 Manual ultrasonic testing for detection of laminar flaws in clad/lined steel shall be done in accordance with ASTM A578/578M or equivalent standard.

208 The surface condition of the material shall permit at least two successive back-wall echoes to be distinguished when the probe is placed on any area free from internal imperfections.

209 The range scale shall be selected such that there are always at least two back-wall echoes (reflections) on the screen.

210 The sensitivity shall be based on echoes reflected from $\varnothing 6$ mm flat bottom holes in reference blocks of the material used or of a material with similar with acoustic properties.

211 DGS diagram or DGS- scales can be used provided they are developed for the probe used and can be correlated to a $\varnothing 6$ mm flat bottom hole.

212 The pitch of the scanning grid shall be small enough to ensure detection of the smallest defect allowed according to the applicable acceptance criteria.

213 Sizing of indications shall be performed according to ISO 10893-9, App.A.

Manual ultrasonic testing for detection of transverse and longitudinal flaws

214 Manual ultrasonic testing for detection of transverse and longitudinal flaws in plate and pipe shall be done in general accordance with ASTM A577 or equivalent standard.

215 Probes shall meet the requirements of 203. Additional angle probes will be required for testing of pipe.

216 Sensitivity for C-Mn and low alloy steel shall be a DAC curve based on reference blocks with a rectangular notch with depth 3% of the material thickness on both sides.

217 Reference blocks for duplex stainless steel and austenitic steels shall have one Ø 3 mm flat bottom hole perpendicular to the angle of incidence of the probe and at the largest possible depth from the scanning surface of the block. Reference blocks shall be of the actual material tested or of a material with similar with acoustic properties.

218 Low frequency shear wave angle probes may be used for duplex stainless steel and austenitic steels instead of twin crystal (transmitter/receiver) compression-wave probes. For acceptance, it shall be verified on the reference blocks that it is possible to obtain a DAC with a shear wave angle probe that is comparable to the DAC obtained with an angle compression wave probe.

219 The pitch of the scanning grid shall be small enough to ensure detection of the smallest defect allowed according to the applicable acceptance criteria.

220 All reference blocks shall be marked with an identification that relates to the specific application of each block.

Magnetic particle testing

221 Manual magnetic particle testing of:

- plate
- pipe
- edges
- bevels

shall be done in accordance with ISO 9934 or equivalent standard.

Liquid penetrant testing

222 Manual liquid penetrant testing of:

- plate
- pipe
- edges
- bevels

shall be done in accordance with ISO3452 or equivalent standard. The penetration and developing times shall be long enough to allow effective detection of the smallest indications allowed.

Eddy current testing

223 Manual eddy current testing of C-Mn steel Pipe shall be done in accordance with ASTM E309 or equivalent standard.

Manual eddy current testing of duplex stainless steels and austenitic stainless steels shall be done in accordance with ASTM E426 or equivalent standard.

C 300 Weld overlay

301 Manual magnetic particle testing of ferromagnetic weld overlay deposits shall be performed in accordance with ISO 9934 or equivalent standard.

302 Manual liquid penetrant testing of non-magnetic weld overlay deposits shall be performed in accordance with ISO 3452 or equivalent standard.

303 Manual eddy current testing of weld overlay deposits shall be performed in accordance with ASTM E309 or equivalent standard.

304 Manual ultrasonic testing of weld overlay shall be performed according to ISO 10893-9, App.A or equivalent standard and:

- Straight beam probes shall be twin crystal. The focusing zone of the twin crystal probes shall be adapted to the material thickness to be examined.
- The surface condition of the material shall permit at least two successive back-wall echoes to be distinguished when the probe is placed on any area free from internal imperfections.
- The calibration of range scale shall be carried out using an IIW calibration block, a V2 calibration block or on a defect free area of known thickness in the material to be examined. The range scale is to be selected such that there are always at least 2 back-wall echoes (reflections) on the screen.
- The sensitivity shall be based on echoes reflected from a Ø 3 mm flat bottom hole in reference blocks made

from a base material with similar acoustic properties of the actual base material with overlay deposited according to the same WPS as the actual overlay. The Ø 3 mm flat bottom hole shall be placed approximately at the fusion line between overlay and base material. If the testing shall be performed of machined overlay, the scanning surface shall be machined to the same surface requirements as the overlay.

— All reference blocks shall be marked with an identification that relates to the specific application of each block.

Reporting

305 Reports shall be in accordance with B105 and B106.

C 400 Visual examination

401 Visual examination shall be carried out in a sufficiently illuminated area; minimum 1000 lx. If required to obtain good contrast and relief effect between imperfections and background additional light sources shall be used.

402 For direct examination the access shall generally permit placing the eye within 600 mm of the surface to be examined and at an angle of not less than approximately 30°. If this is not possible then the use of mirrors, boroscopes, fibre optics or cameras shall be considered.

403 A sufficient amount of tools, gauges, measuring equipment and other devices shall be available at the place of examination.

404 The objects to be examined shall be cleaned to remove all scale and processing compounds prior to examination. The cleaning process shall not injure the surface finish or mask possible imperfections.

405 Reporting of visual examination shall include:

- Name of manufacturer
- Name of examining company
- Identification of examined object(s)
- Material
- Imperfections exceeding the acceptance criteria and their location
- Extent of examination
- Supplementary sketches/drawings.

C 500 Residual magnetism

501 Residual magnetism shall be measured with a calibrated Hall effect gauss meter or equivalent equipment. Four readings shall be taken 90° apart around the circumference of each end of the pipe, and at equal spacing for plate ends. The residual magnetism shall not exceed an average value (out of 4 measurements) of 2.0 mT (20 Gauss), with a maximum single value of 2.5 mT (25 Gauss). Some welding methods may require a more stringent acceptance criterion.

502 Any product that does not meet the requirements of 501 shall be considered defective.

503 All defective products shall be de-magnetized full length, and then their magnetism shall be re-measured until at least three consecutive pipes meet the requirements of 501.

504 The requirements for residual magnetism shall apply only to testing at the specific location since the residual magnetism in products may be affected by procedures and conditions imposed during and after handling and shipment.

C 600 Acceptance criteria for manual non-destructive testing of plate, pipe and weld overlay

Thickness measurements

601 For manual ultrasonic thickness measurements acceptance criteria shall be according to applicable specification or product standard.

Laminar flaws

602 Acceptance criteria for manual ultrasonic testing for laminar flaws in C-Mn, low alloy, duplex, other stainless steels and nickel based corrosion resistant alloys (CRA) are given in Table D-12.

603 Acceptance criterion for manual ultrasonic testing for detection of laminar flaws in clad steel is given in ASTM A263, A264 or A265 and shall correspond to the Class 1 quality level. In addition, no areas with laminations or lack of bonding are allowed over a width extending at least 50 mm inside the location of future weld preparations.

Transverse and longitudinal flaws

604 For manual ultrasonic testing for detection of transverse and longitudinal flaws in C-Mn and low alloy steel, the acceptance criterion shall be that no indications exceed the DAC curve established against the rectangular notch with depth 3% of the thickness.

For manual ultrasonic testing for detection of transverse and longitudinal flaws in duplex stainless steel, the acceptance criterion shall be that no indications exceed the DAC curve established against the Ø 3 mm flat bottom hole.

Magnetic particle testing of plate / pipe bevels and edges

605 Acceptance criterion for manual magnetic particle testing of plate / pipe bevels and edges shall be:

- No indications longer than 6 mm are permitted.

Liquid penetrant testing of plate / pipe bevels and edges

606 Acceptance criterion for manual liquid penetrant testing of plate / pipe bevels and edges shall be:

- no indications longer than 6 mm are permitted.

Eddy current testing of plate / pipe bevels and edges

607 Acceptance criterion for manual eddy current testing of pipe / pipe bevels and edges shall be:

- no indications longer than 6 mm are permitted.

Disposition of defects at plate / pipe bevels and edges

608 Defects at pipe bevels and edges shall be examined ultrasonically as required in this subsection and the pipes cut back until no defects are present in the tested area.

Weld overlay

609 Acceptance criteria for as-welded surfaces of magnetic and non magnetic weld overlay for visual examination, magnetic particle testing, liquid penetrant and eddy current testing are:

- no round indications with diameter above 2 mm and no elongated indications
- indications separated by a distance less than the diameter or length of the smallest indication, shall be considered as one indication
- accumulated diameters of round indications in any 100 × 100 mm shall not exceed 10 mm.

610 Acceptance criteria for ultrasonic testing of as-welded surfaces of magnetic and non-magnetic weld overlay shall be no loss of back wall echo and no echo from an indication shall exceed 66% of the echo reflected from Ø 3 mm flat bottom holes in reference blocks.

611 For machined surfaces, acceptance criteria shall be especially agreed upon.

612 Defects shall be ground out, re-welded and re-tested to meet the acceptance criteria above.

613 When any subsequent process requires homogenous material, i.e. ultrasonic examination, other acceptance criteria shall apply.

D. Non-destructive Testing and Visual Examination of Forgings

D 100 General

101 All non-destructive testing of forgings shall be performed according to accepted procedures.

102 Manual non-destructive testing and visual examination procedures shall be prepared as required in B102 through B104 to reflect the requirements of the applied standard.

103 Acceptance criteria for manual non-destructive testing and visual examination forgings are given in D500.

104 Manual non-destructive testing of forgings shall be performed in compliance with the standards listed below and as required in the following:

- ASTM E165 Standard Test method for Liquid Penetrant Inspection
- ASTM A388 Specification for Ultrasonic Examination of Heavy Steel Forgings
- ISO 9934 Non-destructive testing - Magnetic particle testing
- ASTM A 961 Standard Specification for Common Requirements for Steel Flanges, Forged Fittings, Valves, and Parts for Piping Applications
- ISO 3452 Non-destructive testing - Penetrant testing.

D 200 Ultrasonic and magnetic particle testing of C-Mn and low alloy steel forgings

Ultrasonic testing

201 Ultrasonic testing of forgings shall be performed in accordance with ASTM A388 and the requirements below.

Ultrasonic testing procedures

202 Ultrasonic testing procedures shall contain the information in B102 and:

- type of instrument

- type and dimensions of probes
- range of probe frequencies
- description of reference blocks
- calibration details, range and sensitivity
- surface requirements, including maximum temperature
- type of coupling medium
- scanning techniques supplemented with sketches, showing the probes used and area covered by each probe
- description of methods for recheck of areas with reduction or loss of back reflection
- recording details.

Ultrasonic Apparatus

203 Verification of Screen Height Linearity and Amplitude Linearity shall be performed at the beginning of each period of extended use (or every 3 months, whichever is less). Records shall be made available upon request.

Probes

204 Straight beam probes with frequency 2 to 5 MHz and dimension \varnothing 10 to 30 mm shall be used. The probes shall be single or twin crystal. Twin crystal probes shall be used when testing is performed on material with nominal thickness $t < 60$ mm. The focusing zone of the twin crystal probes shall be adapted to the material thickness to be examined.

Single or twin crystal probes can be used when testing is performed on material with nominal thickness $t \geq 60$ mm. The single crystal probes shall have a dead zone as small as possible, e.g. 10% of the material thickness or 15 mm whichever is the smaller.

205 Angle beam probes shall be used for testing on rings, hollow and cylindrical sections. Angle beam probes shall be available in angles, or be provided with wedges or shoes, ranging from 30° to 75° , measured to the perpendicular of the entire surface of the forging being tested.

Reference blocks for straight beam testing

206 Supplementary requirement S1 of ASTM A388 shall apply, but with the following additional requirements:

- For material thickness $t \leq 38$ mm the flat bottom holes shall be \varnothing 1.6 mm
- For material thickness $38 \text{ mm} < t < 60$ mm the flat bottom holes shall be \varnothing 3 mm
- For material thickness $t \geq 60$ mm the flat bottom holes shall be \varnothing 6 mm.

Reference blocks for angle beam testing

207 The reference notches shall be rectangular D and ID notches with a depth of:

- For material thickness $t \leq 38$ mm, 3% of the thickness
- For material thickness $38 \text{ mm} < t < 100$ mm, 5% of the thickness
- For material thickness $t \geq 100$ mm, 10% of the thickness.

208 A separate reference block shall have the same configuration, nominal composition, forging ratio, heat treatment and thickness as the forgings it represents.

209 Where a group of identical forgings is made, one of the forgings may be used as the separate reference block.

210 All reference blocks shall be marked with an identification that relates to the specific application of each block.

Preparation of forgings for ultrasonic testing

211 For forgings of uncomplicated geometry, the requirements of ASTM A388, chapter 6 shall apply.

Forgings of complex geometry

212 Forgings are required to be forged and/or to be rough machined to near final dimensions prior to heat treatment in order to obtain the required properties. This machining of forgings shall consider that cylindrical shapes and faces that are flat and parallel to one another shall be obtained in order to provide adequate conditions for ultrasonic testing. In the case of forgings with complex geometry, machining shall provide intersecting

cylindrical and/or flat faces. The machining shall be such that areas where adequate ultrasonic testing is not possible will be removed during the final machining. A sketch shall be provided for acceptance showing the areas of the forging where adequate ultrasonic testing will not be achieved.

Calibration of amplification and testing procedure

213 The IIW or ISO calibration blocks (K1 – K2) according to ISO 2400 or ISO 7963 shall be used for calibration of range scale and for angle determination. These calibration blocks shall, as near as practicable, have the same acoustic properties as the material to be tested. Calibration of range scale can alternatively be

done on a defect free area of known thickness in the material to be examined. The range scale is to be selected such that there are always at least 2 back-wall echoes (reflections) on the screen.

214 The calibration of the required amplification shall be performed according to ASTM A388, chapter 7. The probe size and frequency that provides optimum response shall be used for the testing.

215 Notes 2 and 3 of, chapter 7 in ASTM A388 shall be adhered to.

216 When scanning, the gain shall be increased by minimum 6 dB above the corrected primary gain. For evaluation of indications the gain shall be reduced by the increased dB level used during scanning.

217 The method for re-check of areas with reduction or loss of back reflection, ASTM A 388, paragraph 7.2.4, shall be described.

218 Different frequencies, types, angles and diameter of probes shall be employed to obtain additional information about detected indication.

Sizing of indications

219 In general, the area containing imperfections shall be sized (area and length) using the 6 dB drop technique. The area refers to the surface area on the forgings over which a continuous indication exceeds the acceptance criteria. This area will be approximately equal to the area of the real defect provided the defect size is larger than the 6 dB beam profile of the probe.

220 If the real imperfection size is smaller than the 6 dB beam profile, the 6 dB drop technique is not suited for sizing. The area measured on the surface will be measured too large and not represent the real indication size. A guide to classify if the revealed indications are greater or smaller than the 6 dB drop profile is given in EN 10228-3, part 13.

221 If the size of the indication is evaluated to be smaller than the 6 dB drop profile at the depth of discontinuity a graphic plot, that incorporates a consideration of beam spread should be used for realistic size estimation.

Periodical checks of equipment

222 At approximately four-hourly intervals and at the end of testing, the range scale, probe angle and primary gain must be checked and if necessary, corrected. Checks shall also be carried out whenever a system parameter is changed or changes in the equivalent settings are suspected. If deviation is found to be larger than 2% of range scale, or 3 dB of primary gain setting or 2° of nominal angle probe, the testing carried out with the equipment over the previous period shall be repeated.

Reporting

223 Reports shall be in accordance with B105 and B106 and ASTM A388, chapter 9.

Manual magnetic particle testing of C-Mn steel forgings

224 Manual magnetic particle testing of C-Mn steel forgings shall be performed in accordance with ISO 9934 or equivalent standard.

D 300 Ultrasonic and liquid penetrant testing of duplex stainless steel forgings

Ultrasonic testing

301 Ultrasonic testing of duplex stainless steel forgings shall be performed in accordance with D200, but with the following additions to the requirements to:

- probes
- reference blocks for angle beam testing
- preparation of forgings for ultrasonic testing
- testing procedure.

Angle probes

302 Angle probes for duplex stainless steel shall be twin crystal (transmitter/receiver) compression-wave probes. Angle compression wave probes shall and can only be used without skipping.

303 Low frequency shear wave angle probes may be used for duplex stainless steel instead of twin crystal (transmitter/receiver) compression-wave probes, provided it is verified on the reference blocks that it is possible to obtain a DAC with a shear wave angle probe that is comparable to the DAC obtained with an angle compression wave probe.

304 Creep wave probes shall be used for detection of sub surface defects close to the scanning surface, unless testing can be performed from both sides.

Reference blocks for angle beam testing

305 Reference blocks for angle beam testing of duplex stainless steel with angle compression wave probes shall have side drilled holes and a 1 mm deep and 20 mm wide spark eroded notch according to Figure 4 and Table D-7.

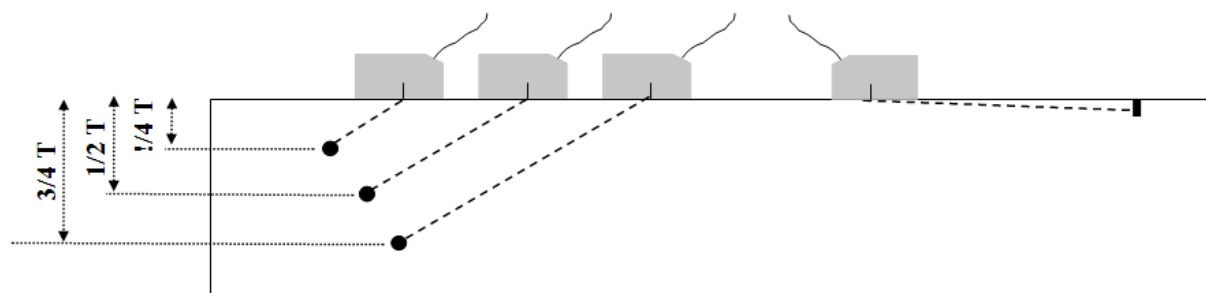

Figure 4
Reference block for construction of DAC, duplex stainless steel

Material thickness (<i>t</i>)	Thickness of reference block (<i>T</i>)	Diameter of side drilled hole mm	Position of side drilled holes
$T < 20 \text{ mm}$	15 mm or <i>t</i>	2.4 ± 0.2	T/4, T/2 and T3/4
$20 \text{ mm} \leq t < 35 \text{ mm}$	20 mm or <i>t</i>	3.0 ± 0.2	
$35 \text{ mm} \leq t < 75 \text{ mm}$	50 mm or <i>t</i>		
$75 \text{ mm} \leq t < 100 \text{ mm}$	90 mm or <i>t</i>	6.0 ± 0.2	The distance between the two outer holes and the nearest surface shall not exceed 12 mm
$100 \text{ mm} \leq t < 150 \text{ mm}$	125 mm or <i>t</i>		

Preparation of forgings for ultrasonic testing

306 The machining of duplex stainless steel forgings for ultrasonic testing shall take into account that angle compression wave probes shall and can only be used without skipping.

Testing procedure

307 The testing procedure for duplex stainless steel forgings shall take into account that angle compression wave probes shall and can only be used without skipping. The testing shall hence be performed from as many faces that access permits.

Manual liquid penetrant testing of duplex stainless steel forgings

308 Manual liquid penetrant testing of duplex stainless steel forgings shall be performed in accordance with ISO 3452 or equivalent standard. The penetration and developing times shall be long enough to allow effective detection of the smallest indications allowed.

309 Reports shall be in accordance with B105 and B106 and ASTM A388, chapter 9.

D 400 Visual examination of forgings

401 Visual examination of forgings shall be performed in accordance with C400, with acceptance criteria according to D500.

D 500 Acceptance criteria for forgings

501 Acceptance criteria for manual ultrasonic testing of forgings shall be:

Straight beam testing

— No single indication shall be larger than the indication received from the flat bottom holes in the reference block required in D200.

Angle beam testing of C-Mn and low alloy steel forgings

— No single indication shall exceed a DAC curve established using the notches in the reference block required in D200.

Angle beam testing of duplex stainless steel forgings

— No single indication shall exceed a DAC curve established using the side drilled holes in the reference

Multiple indications

— No indications within 13 mm of each other in any direction shall exceed 50% of the reference curve.

Acceptance criteria for manual magnetic particle testing of C-Mn and low alloy steel forgings

502 Acceptance criteria for manual magnetic particle testing of C-Mn and low alloy steel forgings shall be according to Table D-8.

Acceptance criteria for manual liquid penetrant testing of duplex stainless steel forgings

503 Acceptance criteria for manual liquid penetrant testing of duplex stainless steel forgings done in accordance with ISO 3452 or equivalent standard shall be according to Table D-8.

A	Crack-like indications: not permitted
B	Linear indications with length more than 2 mm or three times the width: not permitted. Linear indications with length < 1.5 mm may be deemed irrelevant
C	Rounded indications: Diameter < 3 mm, accumulated diameters in any 100 × 150 mm area < 8 mm.

Acceptance criteria for visual examination

504 Acceptance criteria for visual examination of forgings shall be in accordance with ASTM A 961, Chapter 15. If the surface imperfections acceptable under 15.5 are not scattered, i.e. more than 3 off in any 100 × 150 mm area, such imperfections shall be considered injurious.

E. Non-destructive Testing and Visual Examination of Castings

E 100 General

101 All non-destructive testing of castings shall be done according to accepted procedures.

102 Manual non-destructive testing and visual examination procedures shall be prepared as required in B102 through B104 to reflect the requirements of the applied standard.

103 Acceptance criteria for manual non-destructive testing and visual examination of castings are given in E600.

104 Manual non-destructive testing of castings shall be performed in compliance with the standards listed below and as required in the following:

- ASTM E165 Standard Test method for Liquid Penetrant Inspection
- ASTM A609 Standard Practice for Castings, Low Alloy, and Martensitic Stainless Steel, Ultrasonic Examination Thereof.
- ISO 3452 Non-destructive testing - Penetrant testing
- ISO 9934 Non-destructive testing - Magnetic particle testing
- ASME Boiler and Pressure Vessel Code, Section V, Article 2, Mandatory Appendix VII.
- MSSSP-55 Quality standard for steel castings for valves, flanges, and fittings and other piping components (visual method).

E 200 Ultrasonic and magnetic particle testing of C-Mn and low alloy steel castings

201 Manual ultrasonic testing of castings shall be done according to ASTM A609, procedure A, and Supplementary requirement S1. In addition the requirements below apply.

Ultrasonic testing procedures

202 Ultrasonic testing procedures shall contain the information in B102 and:

- type of instrument
- type and dimensions of probes
- range of probe frequencies
- description of reference blocks
- calibration details, range and sensitivity
- surface requirements, including maximum temperature
- type of coupling medium
- scanning techniques supplemented with sketches, showing the probes used and area covered by each probe
- description of methods for re-check of areas with reduction or loss of back reflection
- recording details.

Ultrasonic Apparatus

203 Verification of Screen Height Linearity and Amplitude Linearity shall be performed at the beginning of each period of extended use (or every 3 months, whichever is less). Records shall be made available upon request.

Probes

204 Straight beam (normal) probes with frequency 1-5 MHz and dimension \varnothing 10-30 mm shall be used. Straight beam, normal probes shall be single or twin crystal. Twin crystal probes shall be used when testing is performed on material with nominal thickness $t < 25$ mm. The focusing zone of the twin crystal probes shall be adapted to the material thickness to be examined.

205 Single or twin crystal probes can be used when testing is performed on material with nominal thickness $t \geq 60$ mm. The single crystal probes shall have a dead zone as small as possible, e.g. 10% of the material thickness or 15 mm whichever is the smaller.

Reference blocks

206 All reference blocks shall be marked with an identification that relates to the specific application of each block.

Casting conditions for ultrasonic testing

207 Castings shall as far as possible be machined according to D211 and D212.

Calibration of amplification and testing procedure

208 The IIW or ISO calibration blocks (K1 – K2) according to ISO 2400 or ISO 7963 shall be used for calibration of range scale and for angle determination. These calibration blocks shall, as near as practicable, have the same acoustic properties as the material to be tested. Calibration of range scale can alternatively be done on a defect free area of known thickness in the material to be examined. The range scale is to be selected such that there are always at least 2 back-wall echoes (reflections) on the screen.

209 The calibration of the required amplification shall be performed according to ASTM A609, chapter 8 and S1. The probe size and frequency that provides optimum response shall be used for the testing.

210 Note 3 of ASTM A609, chapter 8: When scanning, the gain shall be increased by minimum 6 dB above the corrected primary gain. For evaluation of indications the gain shall be reduced by the increased dB level used during scanning.

211 Rechecks shall be performed if the loss of back reflection is 50% or greater. The method for further investigation of areas with reduction or loss of back reflection, ASTM A 609 paragraph 8.5, shall be described.

212 Different frequencies, types, angles and diameter of probes shall be employed to obtain additional information about detected indication

Sizing of indications

213 In general, the area containing imperfections, shall be sized (area and length) using the 6 dB drop technique. The area refers to the surface area on the castings over which a continuous indication exceeds the acceptance criteria. This area will be approximately equal to the area of the real defect provided the defect size is larger than the 6 dB beam profile of the probe.

214 If the real imperfection size is smaller than the 6 dB beam profile, the 6 dB drop technique is not suited for sizing. The area measured on the surface will be measured too large and not represent the real indication size. A guide to classify if the revealed indications are greater or smaller than the 6 dB drop profile is given in EN 10228-3, part 13.

215 If the size of the indication is evaluated to be smaller than the 6 dB drop profile at the depth of discontinuity, a graphic plot that incorporates a consideration of beam spread should be used for realistic size estimation.

Periodical checks of equipment

216 At approximately four-hourly intervals and at the end of testing, the range scale, probe angle and primary gain must be checked and corrected. Checks shall also be carried out whenever a system parameter is changed or changes in the equivalent settings are suspected. If deviation is found to be larger than 2% of range scale, or 3 dB of primary gain setting or 2° of nominal angle probe, the testing carried out with the equipment over the previous period shall be repeated.

Reporting

217 Reports shall be in accordance with B105, B106, and ASTM A609, chapters 9 and 19. All indications exceeding 50% of the DAC shall be reported.

Manual magnetic particle testing of C-Mn and low alloy steel castings

218 Manual magnetic particle testing of C-Mn steel castings shall be performed in accordance with ISO 9934 or equivalent standard.

219 Reports shall be in accordance with B105 and B106.

E 300 Ultrasonic and liquid penetrant testing of duplex stainless steel castings

Ultrasonic testing

301 Ultrasonic testing of duplex stainless steel castings shall be performed in accordance with E200, but with

the following additions to the requirements to:

- probes
- reference blocks for angle beam testing
- casting conditions for ultrasonic testing
- testing procedure.

Angle probes

302 Angle probes for duplex stainless steel shall be twin crystal (transmitter/receiver) compression-wave probes. Angle compression wave probes shall and can only be used without skipping.

303 Low frequency shear wave angle probes may be used for duplex stainless steel instead of twin crystal (transmitter/receiver) compression-wave probes, provided it is verified on the reference blocks that it is possible to obtain a DAC with a shear wave angle probe that is comparable to the DAC obtained with an angle compression wave probe.

304 Creep wave probes shall be used for detection of sub surface defects close to the scanning surface, unless testing can be performed from both sides.

Reference blocks for angle beam testing

305 Reference blocks for angle beam testing of duplex stainless steel with angle compression wave probes shall have side drilled holes and a 1 mm deep and 20 mm wide spark eroded notch according to Figure 4 and Table D-7.

Casting conditions for ultrasonic testing

306 Duplex steel stainless castings shall be machined according to D211 and D212.

307 The machining of duplex stainless steel castings for ultrasonic testing shall take into account that angle compression wave probes shall and can only be used without skipping.

Testing procedure

308 The testing procedure for duplex stainless steel castings shall take into account that angle compression wave probes shall and can only be used without skipping. The testing shall hence be performed from as many faces that access permits.

Manual liquid penetrant testing of duplex stainless steel castings

309 Manual liquid penetrant testing of duplex stainless steel castings shall be performed in accordance with ISO 3452 or equivalent standard. Post-emulsified penetrants should be used on precision castings only. The penetration and developing times shall be long enough to allow effective detection of the smallest indications allowed.

310 Reports shall be in accordance with B105 and B106.

E 400 Radiographic testing of castings

General

401 Radiographic testing of castings shall be done according to ASME Boiler and Pressure Vessel Code, Sec.5, article 2, mandatory appendix VII or equivalent standard. In addition, the applicable requirements of B200 and the requirements below shall apply.

Procedures

402 Radiographic procedures shall in addition to the requirements of B203, give the following information:

- shooting sketches
- coverage
- source location
- location of IQI
- acceptance criteria.

E 500 Visual examination of castings

501 Visual examination of castings shall be performed in accordance with C400 and MSS SP-55.

502 Reports shall be in accordance with C405.

E 600 Acceptance criteria for castings

General

601 Acceptance criteria shall apply for the entire casting or portions of the casting. If different acceptance criteria shall apply for different portions of the casting, the critical areas of the casting shall be defined.

Guidance note:

Critical areas shall include abrupt changes of sections and at the junctions of risers, feeders and gates to the casting. Highly stressed areas such as weld necks shall be considered as critical areas.

---e-n-d---of---G-u-i-d-a-n-c-e---n-o-t-e---

602 Acceptance criteria for manual ultrasonic straight beam testing of castings shall be:

- No crack-like indications are acceptable, and
- According to Table D-9.

Table D-9 Ultrasonic testing acceptance criteria for castings	
Straight beam testing ASTM A609, 10.2.1, 10.2.2 and 10.2.3	
Critical areas	Other areas
Table 2, Quality Level 1	Table 2, Quality Level 3
Angle beam testing ASTM A609 S1.4.1 and Table 2	
Critical areas	Other areas
Table 2, Quality Level 1	Table 2, Quality Level 3

603 Acceptance criteria for manual radiographic testing of critical areas of castings shall be according to Table D-10:

Table D-10 Radiographic acceptance criteria for castings		
<i>Type of defect</i>	<i>Acceptance criteria</i>	
	<i>Standard</i>	<i>Maximum Severity Level</i>
Gas porosity	ASTM E280	2
Inclusions		2
Shrinkage		2
Cracks		0
Hot tears		0
Inserts		0

604 Acceptance criteria for manual magnetic particle testing and manual liquid penetrant testing of castings shall be according to Table D-11.

Table D-11 Acceptance criteria for manual magnetic particle and liquid penetrant testing of castings	
A	Crack-like defects: not permitted
B	Linear indications with length more than three times the width: not permitted. Linear indications with length < 1.5 mm may be deemed irrelevant.
C	Rounded indications: Diameter < 3 mm, accumulated diameters in any 100 × 150 mm area < 8 mm.

605 Acceptance criteria for visual inspection of castings shall be in accordance with MSS SP-055.

- Type 1: Not acceptable
- Types 2 to 12: A and B.

Repairs by welding

606 Complete removal of the defect shall be confirmed by magnetic particle testing, or liquid penetrant testing for non-ferromagnetic materials, before re-welding.

607 Repair welds of castings shall meet the acceptance criteria designated for the particular portion of the casting.

F. Automated Non-Destructive Testing

F 100 General

101 These requirements are applicable to all automated NDT processes except automated ultrasonic testing of girth welds where specific requirements are given in Appendix E. The requirements given in this subsection are additional to the requirements of any code or standard where automated NDT methods are prescribed or optional.

102 Automated non-destructive testing can replace manual non-destructive testing or one automated non-destructive testing method/system can replace another automated non-destructive testing method/system provided

the equivalence of systems is documented with regard to function, operation, ability in detection and sizing and performance.

103 Documentation of capability/performance and qualification of automated NDT systems in pipe mills should not be required for systems meeting the documentation requirements given in H404.

F 200 Documentation of function and operation

The automated NDT equipment shall be documented with regard to function and operation. Items subject to documentation include:

- brief functional description of the equipment
- detailed equipment description
- operation manual including type and frequency of functional checks
- calibration
- limitations of the equipment with regard to material or weld features including size, geometry, type of flaws, surface finish, material composition etc.
- repeatability.

F 300 Documentation of performance

301 The capability and performance of automated NDT equipment shall be documented by statistical records covering, as relevant:

- accuracy in indication sizing (random and systematic deviation)
- accuracy in positioning / location
- defect characterisation abilities compared to the results of other NDT performed
- repeatability, and
- probability of detection values or data for different threshold settings to determine the threshold to be used for required detection during testing.

Guidance note:

Automated non-destructive testing equipment can generally be divided into two groups. One group consists of equipment intended for detection, sizing and positioning of indications (typically real time radiography) and one group consisting of equipment intended for detection only and where sizing and positioning of indications is performed by other means (typically ultrasonic testing of the weld seam according to ISO 10893-11). For the latter types of equipment, documentation of performance may be limited to demonstration of adequate detection of defects typical for the manufacturing process, threshold setting parameters and repeatability.

---e-n-d---of---G-u-i-d-a-n-c-e---n-o-t-e---

F 400 Qualification

401 A full qualification programme for automated NDT equipment will in general comprise the following stages:

- initial evaluation and conclusions based on available information
- identification and evaluation of significant parameters and their variability
- planning and execution of a performance test programme
- reference investigations.

F 500 Evaluation of performance documentation

501 As a minimum a qualification will involve an assessment of the automated NDT equipment technical documentation, including the quality assurance system, and available information on equipment capability and performance. Limited practical tests must be performed in many cases.

G. Non-Destructive Testing at Plate and Coil Mill

G 100 General

101 The non-destructive testing during manufacture of plate and coil shall be performed according to documented procedures.

102 The testing shall include testing of a band along the four edges of plate for laminar imperfections. A suitable allowance in the width of the band shall be made to compensate for possible oversized plates and subsequent edge milling and end bevelling.

103 Testing of coil, e.g. for HFW pipe, may alternatively be substituted with testing of finished pipe at the pipe mill.

104 The width of the band at the longitudinal plate edges shall extend:

- at least 50 mm inside the location of future welding preparations for SAW longitudinal welds
- At least 15 mm inside the location of future welding preparations for HFW longitudinal welds.

105 The width of the band at the transverse plate edges should extend:

- at least 50 mm inside the location of future welding preparations for girth welds.

Additional non-destructive testing

106 Any additional non-destructive testing shall be specified by the purchaser.

107 If automated ultrasonic testing of girth welds during installation will be performed the width of the band should extend at least 150 mm inside the location of future welding preparations for girth welds.

108 If allowance for re-bevelling of pipe shall be included, the width of the band should extend at least 100 mm inside the location of future welding preparations for girth welds.

109 For detection of cracks angle probes shall be used to supplement the straight beam probes. Testing shall be in general accordance with ASTM A577 or equivalent standard and:

- Probes shall meet the requirements of C203.
- Sensitivity for C-Mn steel shall be a DAC curve based on reference blocks with a rectangular notch with depth 3% of the material thickness on both sides.
- Reference blocks for duplex stainless steel and austenitic steels shall have one Ø3 mm flat bottom hole perpendicular to the angle of incidence of the probe and at the largest possible depth from the scanning surface of the block. Reference blocks shall be of the actual material tested or of a material with similar with acoustic properties.
- Low frequency shear wave angle probes may be used for CRA material instead of twin crystal (transmitter/receiver) compression-wave probes. For acceptance, it shall be verified on the reference blocks that it is possible to obtain a DAC with a shear wave angle probe that is comparable to the DAC obtained with an angle compression wave probe.

110 The acceptance criterion is:

- No indications shall exceed the DAC.

G 200 Ultrasonic testing of C-Mn steel and CRA plates

201 Ultrasonic testing for laminar imperfections shall be in accordance with ISO 10893-9 amended as follows:

- the distance between adjacent scanning tracks shall be sufficiently small to ensure detection of the minimum imperfection size to be considered in the plate body and all four automated systems shall incorporate lack of coupling alarm.

Automated UT-systems with automatic routines for scan interpretation of plates

202 Ultrasonic inspection systems with fully automated routines for accept/reject of plates shall incorporate options for manual evaluation of all reported indications and manual override of the system.

203 Any manual overriding of accept/reject conclusions from a fully automatic plate evaluation system shall be documented in the scan report.

204 Acceptance criteria for ultrasonic testing of C-Mn and CRA plate for laminar imperfections are given in Table D-12.

Table D-12 Ultrasonic testing, acceptance criteria for laminar imperfections				
<i>Acceptance criteria for body</i>				
<i>Service</i>	<i>Maximum allowed imperfection</i>	<i>Minimum imperfection size to be considered</i>	<i>Size of reference area</i>	<i>Maximum population density</i>
Non-sour	Area: 1 000 mm ²	Area: 300 mm ² Length: 35 mm Width: 8 mm	1 000 mm × 1 000 mm	10 within the reference area
Sour	Area: 500 mm ²	Area: 150 mm ² Length: 15 mm Width: 8 mm	500 mm × 500 mm	5 within the reference area

Table D-12 Ultrasonic testing, acceptance criteria for laminar imperfections (Continued)

<i>Acceptance criteria for edges</i>				
<i>Service</i>	<i>Maximum allowed imperfection</i>	<i>Minimum size of imperfection to be considered</i>	<i>Size of reference area</i>	<i>Maximum population density</i>
All	Area: 100 mm ² Width: 6 mm	Length: 10 mm	1 000 mm length	3 within the reference area
Notes:				
1) For an imperfection to be larger than the minimum imperfection to be considered, all dimensions, e.g. min area, min length and min width, will have to be exceeded (for body).				
2) Two or more adjacent imperfections shall be considered as one imperfection if they are separated by less than the smaller dimension of either indication.				
3) The population density shall be the number of imperfections smaller than the maximum allowed and larger than the minimum imperfection size to be considered				
4) The reference area for plate/coil when the plate width is less than one side of the square reference area shall be 1.00 m ² for non-sour and 0.25 m ² for sour service.				
5) The width of an imperfection is the dimension transverse to the longitudinal edge of the plate/coil or for pipe the longitudinal axis.				

205 Subject to agreement the acceptance criteria for the body of plate and coil can be limited to an allowed permitted area of 100 mm² and a population density of 5 and with the minimum imperfection size area 30 mm², length and width 5 mm. All other requirements in Table D-12 shall apply.

G 300 Ultrasonic testing of CRA clad C-Mn steel plate

301 For ultrasonic testing of the backing material the requirements of G100 and G200 shall apply.

302 Ultrasonic testing for the detection of lack of bond between the C-Mn backing material and CRA shall be performed in accordance with ASTM A578, S7 amended as follows:

— the distance between adjacent scanning tracks shall be sufficiently small to ensure detection of the minimum imperfection size to be considered in the plate body and all four edges.

303 Acceptance criteria are:

— ASTM A578, S7. In addition, no areas with laminations or lack of bond are allowed in the plate edge areas.

G 400 Alternative test methods

401 If agreed alternative methods of testing may be acceptable, if the alternative test method is documented as required in H402 and the alternative test method is demonstrated to give at least the same sensitivity and capability in detection of imperfections.

402 The demonstration of the alternative test method shall be based on the principles given in Subsection F and using samples of plate similar to those ordered. The plates shall contain a representative and agreed size range of natural and/or artificial defects of types that are typical for the manufacturing process in question.

G 500 Disposition of plate and coil with unacceptable laminations or inclusions

501 Plates and coil that contain unacceptable laminations or inclusions shall be rejected or, if possible, be cut back until no lamination or inclusion exceeding the acceptance criteria is present in the plate/coil.

G 600 Visual examination of plate and coil

601 Visual examination shall be carried out in a sufficiently illuminated area, minimum 1000 lx on the area of interest is recommended. If required to obtain good contrast and relief effect between imperfections and background additional light sources shall be used.

602 For direct examination the access shall generally permit placing the eye within 600 mm of the surface to be examined and at an angle of not less than approximately 30°.

Guidance note:

The production process of coil can make it difficult or impossible to perform visual inspection. The coil can be too hot, moving too fast and not be sufficiently clean to be able to visually inspect. In such cases the visual inspection, if required, must be performed at a later stage of the pipe production process.

---e-n-d---of---G-u-i-d-a-n-c-e---n-o-t-e---

603 A sufficient amount of tools, gauges, measuring equipment and other devices shall be available at the place of examination.

604 The objects to be examined shall be cleaned to remove all scale and processing compounds prior to examination. The cleaning process shall not injure the surface finish or mask possible imperfections.

G 700 Acceptance criteria and disposition of surface imperfections

Acceptance criteria

701 Plate/coil shall meet the acceptance criteria specified by the pipe mill. The acceptance criteria shall under no circumstance be less stringent than the applicable requirements for pipe, as specified in H500.

702 Imperfections shall be dressed out by grinding. Ground areas shall blend smoothly into the surrounding material. Complete removal of defects shall be verified by local visual inspection and shall be supplemented with a suitable surface inspection method. The remaining wall thickness in the ground area shall be checked by ultrasonic wall thickness measurements to verify that the thickness of the remaining material is more than the specified minimum. Imperfections that encroach on the minimum permissible wall thickness after grinding shall be classified as defects.

Disposition of plate with defects

703 Plate and coil that contain defects shall be rejected or, if possible, be cut back until no defect is present in the plate/coil.

H. Non-Destructive Testing of Linepipe at Pipe Mills

H 100 General

101 The extent of non-destructive testing during manufacture of linepipe shall be as required in Sec.7 F.

102 The types of testing required are defined as:

- ultrasonic testing
- surface imperfection testing
- radiographic testing.

Whenever the choice of non-destructive testing methods is optional, this is indicated in this subsection.

103 Non-destructive testing shall be performed in compliance with the standards listed below and as required in this subsection:

Electromagnetic (flux leakage)

ISO 10893-3 Non-destructive testing of steel tubes - Part 3: Automated full peripheral flux leakage testing of seamless and welded (except submerged arc-welded) ferromagnetic steel tubes for the detection of longitudinal and/or transverse imperfections

Electromagnetic (eddy current)

ISO 10893-2 Non-destructive testing of steel tubes - Part 2: Automated eddy current testing of seamless and welded (except submerged arc-welded) steel tubes for the detection of imperfections

Radiographic

ISO 10893-6 Non-destructive testing of steel tubes - Part 6: Radiographic testing of the weld seam of welded steel tubes for the detection of imperfections

ISO 10893-7 Non-destructive testing of steel tubes - Part 7: Digital radiographic testing of the weld seam of welded steel tubes for the detection of imperfections

Ultrasonic

ISO 10893-8 Non-destructive testing of steel tubes - Part 8: Automated ultrasonic testing of seamless and welded steel tubes for the detection of laminar imperfections

ISO 10893-10 Non-destructive testing of steel tubes - Part 10: Automated full peripheral ultrasonic testing of seamless and welded (except submerged arc-welded) steel tubes for the detection of longitudinal and/or transverse imperfections

ISO 10893-11 Non-destructive testing of steel tubes - Part 11: Automated ultrasonic testing of the weld seam of welded steel tubes for the detection of longitudinal and/or transverse imperfections

ISO 10893-12 Non-destructive testing of steel tubes - Part 12: Automated full peripheral ultrasonic thickness testing of seamless and welded (except submerged arc-welded) steel tubes

Liquid penetrant

ISO 10893-4 Non-destructive testing of steel tubes - Part 4: Liquid penetrant inspection of seamless and welded steel tubes for the detection of surface imperfections

Magnetic particle

ISO 10893-5 Non-destructive testing of steel tubes - Part 5: Magnetic particle inspection of seamless and welded ferromagnetic steel tubes for the detection of surface imperfections

104 All NDT shall be performed according to documented procedures that, as a minimum, give information on the following aspects:

- applicable code(s) or standard(s)
- welding method (when relevant)
- joint geometry and dimensions (when relevant)
- material
- NDT method
- technique
- equipment, main and auxiliary
- consumables when relevant (including brand name)
- coverage calculation supplemented with sketches
- sensitivity
- calibration references and technique
- trigger or alarm settings
- for ultrasonic testing equipment the procedure shall describe the method for setting and checking the lack of coupling alarm
- assessment of imperfections
- method for demonstrating compliance of equipment with the assumptions in the procedure
- reporting and documentation of results
- assessment of imperfections, including “decision tree” corresponding with internal organization.

105 Personnel performing NDT shall be qualified according to A500.

106 All NDT for final acceptance of pipe shall be performed after completion of any cold expansion and heat treatment operations.

For seamless pipe, the NDT for final acceptance may be performed prior to cropping, bevelling and end sizing. Cold straightening and cold sizing of seamless pipe ends imposing a maximum strain of 1.5% may be performed after surface testing of the pipe body but prior to testing of pipe ends.

All NDT for “in-house” purposes may be performed at any time at the Manufacturer's discretion.

107 If NDT of plate in accordance with subsection G is performed at the plate mill, ultrasonic testing for laminar imperfections may be omitted at the pipe mill.

108 Reporting of NDT shall be according to the requirements of the applicable ISO standard unless otherwise agreed.

H 200 Suspect pipe

201 In all cases when pipe inspection results in the automated NDT system is giving signals equal to or greater than the threshold level or when surface imperfections are disclosed by visual examination, the pipe shall be deemed suspect.

Suspect pipe can be dealt with according to one of the following options:

- the suspect pipe can be re-inspected using the automated NDT equipment in the static mode. Pipes passing these tests are deemed acceptable
- the suspect area of the pipe can be re-tested by manual NDT using the same NDT method and sensitivity as the automated NDT, and using appropriate techniques. Pipes passing these tests are deemed acceptable
- the suspect area of welds, except HFW welds, can be radiographed to determine if the indication is caused by slag or porosity type indications. Pipes meeting the requirements of ISO 10893-6 are deemed acceptable
- defective welds, except HFW welds, can be repaired by welding according to H301 through 307
- defects can be removed by grinding according to H308
- the suspect area can be cut off if the minimum specified length is met after cutting
- the pipe can be scrapped.

If the suspect area is cut off, then all NDT requirements pertaining to pipe ends shall be performed on the new pipe end.

H 300 Repair of suspect pipe

Repair welding

301 Repair welding of pipe body or repair welding of welds in HFW pipe is not permitted.

302 Repair welding of cracks is not permitted unless the cause of cracking has been established not to be a systematic welding error. (If there is a crack in the weld the pipe is per definition considered rejected.) This means a technical evaluation of the cause of cracking shall be performed. If it can be demonstrated that the crack is a “one off” situation, repair welding may be performed subject to agreement)

303 Repair welding shall be performed according to qualified repair welding procedures. Each repair shall be performed with a minimum of two passes over a length not less than 50 mm.

- 304** The total length of weld repair in any single pipe shall not exceed 5% of the weld length.
- 305** Weld defects separated by less than 100 mm shall be repaired as a single continuous repair.
- 306** Re-inspection of repair welds shall be 100% visual examination and 100% ultrasonic and/or 100% radiographic testing as required for the original weld.
- 307** Acceptance criteria for weld repairs shall be as for the original weld.

Repair of welds by grinding

308 Surface defects may be dressed out by cosmetic grinding. Ground areas shall blend smoothly into the surrounding material. Complete removal of defects shall be verified by local visual inspection and shall be supplemented with a suitable surface inspection method. The remaining wall thickness in the ground area shall be checked by ultrasonic wall thickness measurements to verify that the thickness of the remaining material is more than the specified minimum. Imperfections that encroach on the minimum permissible wall thickness and/or weld thickness shall be classified as defects.

Repair of pipe body by grinding

309 Repair of pipe body by grinding shall be performed according to H525 through 527.

Disposition of pipe containing defects

310 Disposition of pipe containing defects after repair shall be according to H528.

H 400 General requirements for automated NDT systems

Alternative methods of testing

401 Subject to agreement, alternative methods of testing may be accepted if the alternative test method is documented as required in H402 and the alternative test method is demonstrated to give at least the same sensitivity and capability in detection of imperfections.

402 The demonstration of the alternative test method shall be based upon the principles given in Subsection F and using sample lengths of pipe similar to those ordered. The pipes shall contain a representative and agreed size range of natural and/or artificial defects of types that are typical for the manufacturing process in question.

System calibration

403 All automated NDT systems shall have a full system calibration with intervals not exceeding 12 months. Documentation shall be available.

Documentation of system capabilities

404 Documentation of automated NDT systems shall be available to demonstrate that the systems are capable of detecting the reference indicators used to establish the specified test sensitivity. The documentation shall, as a minimum cover:

- NDT system operating procedures
- capability for the intended wall thickness
- capability for the intended material
- repeatability
- detection of defects typical for the manufacturing process with the equipment in question
- threshold level setting parameters
- dynamic test data demonstrating the systems capability under production test conditions.

Reference standards for ultrasonic and electromagnetic inspection

405 Reference standards shall meet the requirements of the applicable ISO standard and the requirements given in this appendix.

406 The reference standard shall be a length of pipe with the same outside diameter and wall thickness tolerances and with similar acoustic properties as the pipe tested during production. For welded pipe the reference standard shall contain a weld typical for the production weld to be tested.

407 Reference standards may be of any convenient length as decided by the manufacturer.

408 Reference standards shall contain reference indicators as required by this Appendix for the pipe to be tested.

409 Verification of the dimensions and shape of all reference indicators shall be performed according to a documented procedure. Documentation shall be available. All reference standards shall be marked with an identification that relates to the specific application of each reference standard.

Validation of length of pipe tested

410 When automated non-destructive testing equipment is used, a short area at both pipe ends will normally not be tested. A sample pipe shall be fitted with one \varnothing 3.0 mm through drilled hole at the weld centerline at each end. The distance from the pipe end to the hole shall be equal to the length not covered by the automated testing equipment during production testing. Prior to start of production the pipe shall be passed through the

ultrasonic testing equipment at the operational scanning velocity. For acceptance of the equipment, both holes shall be detected by all probes/focal law. These holes can be introduced in the reference block. If ≈ 3.0 mm through drilled hole at the weld centerline at each end is unsuitable to register at scanning sensitivity for the technique introduced to the inspection Set Up, alternative reference reflectors shall be proposed and agreed on.

Scanning velocity

411 The scanning velocity shall be selectable. The scanning velocity shall be set low enough so that the length between the activation of each probe (spatial resolution) is sufficiently short, i.e. the distance the probe travels while inactive, shall be significantly less than the maximum length of allowable imperfections.

412 The scanning velocity V_C for inspection of longitudinal welds shall be determined according to:

$$V_C \leq W_C \cdot PRF / 3$$

Where W_C is the narrowest - 6 dB effective beam width at the appropriate distance of all probes within the array and PRF is the effective pulse repetition frequency per probe.

413 The circumferential scanning velocity for inspection of seamless pipe and helical welds shall be decided depending on effective pulse spacing (pulse density) and on circumferential scanning speed and helical pitch. The effective pulse spacing (EPS) is specified as follows:

- EPS = circumferential scanning speed/PRF
- EPS shall not exceed 1 mm/pulse.
- The helical pitch (mm/revolution) shall not exceed the narrowest - 6 dB effective beam width of all probes within the array.

Lack of coupling

414 Automated ultrasonic testing systems shall incorporate a system for detection of lack of coupling. The settings for lack of coupling alarm and check of the settings shall be described in the manufacturer's written procedure.

Initial sensitivity and threshold settings (calibration)

415 The sensitivity and threshold settings shall be established according to a documented procedure. The system shall be optimised in the static mode. When the settings are optimised, the relevant parameters shall be recorded and the reference standard shall be passed 3 times through the equipment at the operational velocity. Any change in settings required to maintain the static mode settings shall be recorded as an average of the 3 runs. For acceptance of the settings, all reference reflectors need to be detected at or above the threshold.

416 During production testing the relative speed of movement between the pipe and the test assembly shall not exceed that used for the sensitivity and/or alarm settings during dynamic calibration.

Verification of sensitivity and threshold settings (calibration)

417 The sensitivity and/or alarm settings shall be verified every fourth hour or once every 10 pipes tested, whichever is the longer period, and:

- at the start and end of each shift
- at any change of equipment operator (for continuous shifts the end and start verification can be combined)
- whenever a malfunction of the equipment is suspected.

The verification frequency when manufacturing HFW pipe from coil shall be agreed upon. As a minimum the frequency shall be at the beginning and end of an inspection and at any stops in production.

Resetting of sensitivity and threshold settings (recalibration)

418 Resetting of sensitivity and threshold settings shall be performed whenever:

- the standard reflectors do not trigger the alarm during verification of sensitivity and threshold settings
- a change of component affecting the sensitivity and/or alarm setting is made in the system
- the verification of sensitivity and/or alarm settings fails to meet the requirements for the particular equipment.

For re-setting of sensitivity and threshold settings during production the settings shall be optimised in the static mode. When the settings have been optimised, the reference standard shall be passed once through the equipment at the operational velocity. Any change in settings required to maintain the static mode settings shall be recorded. For acceptance of the settings, all reference reflectors need to be detected at or above the threshold.

Retesting of pipes

419 If the verification of sensitivity and threshold settings fails to meet the requirements for the particular equipment, all pipes inspected since the previous successful verification shall be retested.

Specific requirements for ultrasonic testing equipment for welds

420 The equipment shall be capable of inspecting the entire thickness of the weld seam.

421 Before starting production testing, the range scale and angle of all probes shall be demonstrated to comply with the documented procedure.

422 Equipment for testing of welds shall have a weld tracking system. The system should be capable of tracking the weld centreline with an accuracy of ± 2 mm or better. For systems not meeting this requirement it shall be documented that:

- the sensitivity during production testing will not be affected by the lower accuracy of the tracking system
- that the lower accuracy is compensated by system sensitivity and gate settings.

423 The gates shall be set wide enough to cover 3 mm of the base material outside the fusion line and to compensate for:

- the tolerances of weld tracking system
- variations in the width of external and internal caps
- offsets between the external and internal weld bead.

Ultrasonic testing of CRA pipes and welds with CRA weld deposits

424 Ultrasonic testing of welds with CRA (duplex, other stainless steels and nickel alloy steel) weld deposits will in order to achieve an adequate detection of imperfections, normally require that special reference blocks and probes are used for testing of these materials.

425 Angle probes for duplex stainless steel and austenitic steels shall be twin crystal (transmitter/receiver) compression-wave probes. Angle compression wave probes shall and can only be used for scanning without skipping and creep wave probes must therefore be used for detection of sub-surface defects close to the scanning surface.

426 Reference blocks for duplex stainless steel and austenitic steels materials and the weld deposits shall have a specific location and type of reference reflectors in general compliance with B400. Surface notches will not be suitable due to the mode conversions at base material and a surface notch. This will result in multiple echoes with different arrival time appearing from the same notch. The actual reflection from the reflector will be weak and distinguishing this echo from other signals will often not be possible.

427 Specific ultrasonic testing procedures shall be developed for this testing. The procedures shall be developed considering the requirements B400 and addressing the specific features and characteristics of the equipment to be used.

428 It is recognised that not all equipment will be adaptable to meet the requirements above.

429 Low frequency shear wave angle probes may be used for duplex stainless steel and austenitic steels instead of the angle compression wave probes, provided it is verified on reference blocks made in accordance with B400 that it is possible to obtain a DAC with shear wave angle probe(s) that is comparable to a DAC obtained from angle compression-wave probes. The shear wave angle probes used for this verification shall be identical to the probes used in the production testing equipment.

430 If it is not possible to demonstrate adequate performance of low frequency shear wave angle probes for ultrasonic testing of duplex stainless steel and austenitic steels, other methods or combination of methods shall be used and the adequacy of the method(s) demonstrated.

431 Notches and through drilled holes are not considered a suitable reflector for compression wave angle probes due to the mode conversion and unpredictable arrival times of mode converted signals. When compression wave angle probes are used, other types of reflectors shall be used and the acceptance criteria specified accordingly.

Specific requirements for radiographic testing

432 Radiographic testing shall be performed in accordance with ISO 10893-6, image class B using wire type Image Quality Indicators (IQI) in accordance with ISO 19232-1 or step/hole type on ISO 19232-2.

433 Digital Radiographic testing techniques in accordance with ISO 10893-7 can be used provided the equipment has been demonstrated, in accordance with Subsection F, to give sensitivity and detection equivalent to conventional x-ray according to ISO 10893-6.

434 If radiosopic testing techniques are used, the quality of the ray image has to be verified as required in 417.

H 500 Visual examination and residual magnetism

General

501 Visual examination shall be carried out in a sufficiently illuminated area; minimum 1000 lx. If required additional light sources shall be used to obtain good contrast and relief effect between imperfections and background.

502 In accordance with Sec.7, Table 7-16, each linepipe shall be subject to 100% visual inspection. This implies 100% visual inspection of the outside of the pipe body. The interior of the pipe shall be inspected from both ends as far as access permits. The interior of duplex stainless steel and clad/lined material should be 100% visually inspected.

503 A sufficient amount of tools, gauges, measuring equipment and other devices shall be available at the place of examination.

504 The pipes to be examined shall be cleaned to remove loose scale and processing compounds that may interfere with the examination. The cleaning process shall not affect the surface finish or mask possible imperfections.

505 Subject to agreement, alternative methods of testing may be accepted. It shall be demonstrated that the alternative test method give at least the same sensitivity and capability in detection of imperfections. The demonstration of the alternative test method shall be based upon the principles given in Subsection F on similar pipes to those ordered. The pipes shall contain a representative and agreed size range of natural and/or artificial defects of types that are typical for the manufacturing process in question.

Visual examination of all linepipe

506 End preparation such as bevelling shall meet the specified requirements.

507 The internal weld bead shall be removed by grinding for a distance of at least 100 mm from each pipe end. The transition between base material and weld metal shall be smooth and the height of the remaining weld bead shall not extend above the adjacent pipe surface by more than 0.5 mm.

508 If specified, the external weld bead shall be removed by grinding for a distance of at least 250 mm from each pipe end. The transition between base material and weld metal shall be smooth and the height of the remaining weld beads shall not extend above the adjacent pipe surface by more than 0.5 mm.

Visual examination of welds in linepipe

509 Each linepipe weld shall be subject to 100% visual examination in accordance with ISO 17637. For C-Mn steel linepipe with internal diameter (ID) ≥ 610 , the internal weld shall be 100% visually inspected. The internal weld of C-Mn linepipe with ID < 610 mm shall be inspected from both ends as far as access permits.

510 The internal weld and adjacent surfaces in duplex stainless steel, CRA and clad linepipe shall be inspected full length. If necessary, the inspection of the internal weld shall be assisted by a boroscope, video endoscope or similar equipment.

511 Welds shall meet the requirements of Table D-4.

512 Line pipe containing welds not meeting the requirements above shall be classified as suspect pipe according to H200, and treated according to H300.

Surface conditions, imperfections and defects

513 The surface finish produced by the manufacturing process shall be such that surface defects can be detected by visual inspection.

514 All pipes shall be free from defects in the finished condition. The manufacturer shall take adequate precautions to prevent pipe damage and minimise the presence of imperfections.

515 Cracks, sweats or leaks are not acceptable and shall be classified as defects.

516 Surface imperfections evident by visual inspection shall be investigated, classified and treated as according to H517 to H522. H519 applies to surface imperfections at the internal surface of clad or lined pipes.

517 Imperfections with depth $\leq 5\%$ of the specified wall thickness, or 0.5 mm, whichever is greater, but maximum 0.7 mm for $t \leq 25$ mm, and maximum 1.0 mm for $t > 25$ mm, and which do not encroach upon the specified minimum wall thickness, shall be classified as acceptable imperfections. The imperfections may remain in the pipe or be dressed out by cosmetic grinding.

518 Imperfections with depth larger than stated in H517, and which do not encroach upon the specified minimum wall thickness, shall be classified as dressable defects and shall either be removed by grinding in accordance with H525 or treated in accordance with H528, as appropriate.

519 For the internal surface of clad or lined pipes the following applies: Imperfections with depth ≤ 0.5 mm, and which do not encroach upon the specified minimum wall thickness, shall be classified as acceptable imperfections. The imperfections may remain in the pipe or be dressed out by cosmetic grinding. Imperfections with larger depth, and which do not encroach upon the specified minimum wall thickness, shall be classified as dressable defects and shall either be removed by grinding in accordance with H525 or treated in accordance with H528, as appropriate.

520 Imperfections which encroach upon the specified minimum wall thickness shall be classified as defects.

521 Two or more adjacent imperfections shall be considered as one imperfection if they are separated by less than the smaller dimension of either indication.

522 Imperfections with depth according to H517 or H519 of which the depth can not be assessed by suitable

gauges or alternative means, shall either be removed by grinding in accordance with H525 or treated in accordance with H528, as appropriate.

Dents

523 For dents without any cold formed notches and sharp bottom gouges, the length in any direction shall be $\leq 0.5 D$ and the depth, measured as the gap between the extreme point of the dent and the prolongation of the normal contour of the pipe, shall not exceed 6.4 mm.

- For dents with cold-formed notches and sharp bottom gouges with depth according to H517 the depth of dents shall not exceed 3.2 mm.
- Dents > 1 mm are not acceptable at the pipe ends, i.e. within a length of 100 mm at each of the pipe extremities.
- Dents exceeding these dimensions shall be classified as defects.

Hard spots

524 Hard spots, as identified e.g. due to irregularities in the pipe curvature of cold-formed welded linepipe, shall be investigated to determine the hardness and dimensions of the area.

For linepipe intended for non sour service the hardness shall not exceed:

- 300 HV10 for C-Mn steels
- the values given in Sec.7 Table 7-11, for the material in question.

For linepipe intended for sour service (Supplementary requirement S) the hardness shall not exceed:

- 250 HV10 C-Mn steel unless a higher hardness has been qualified according to Sec.6 B202 and App.B C400.
- for other steels, maximum allowable hardness according to ISO 15156-3.

Hard spots outside the hardness requirements for the applicable material larger than 50 mm in any direction and within 100 mm of the pipe ends regardless of size shall be classified as defects.

Grinding

525 Imperfections or defects according to H518 or H519 may be dressed-out by grinding. Ground areas shall blend smoothly into the surrounding material. Complete removal of defects shall be verified by local visual inspection and shall be supplemented with a suitable surface inspection method. The remaining wall thickness in the ground area shall be checked by ultrasonic wall thickness measurements to verify that the thickness of the remaining material is more than the specified minimum.

526 The sum of the ground area shall not exceed 10% of the sum of the external and internal surface area of each pipe. Ground areas which have been smoothly blended into the surrounding material and classified as cosmetic grinding shall not be counted in the calculation.

527 Full length machining of pipes is acceptable if machining is performed according to a qualified procedure that ensures freedom from circumferential grooves or other defects with depth > 0.5 mm. H526 does not apply to pipe that are machined full length.

Disposition of pipe containing defects

528 Linepipe containing defects shall be rejected or the area containing defects can be cut off. If pipes are cut, the minimum specified length shall be met after cutting and all NDT pertaining to pipe ends shall be performed on the new pipe end.

Residual magnetism

529 The longitudinal magnetic field shall be measured on pipe with $D \geq 168.3$ mm and all smaller pipes that are inspected full length by magnetic methods or are handled by magnetic equipment prior to loading.

- The measurements shall be taken on the root face or square cut face of finished pipe. Measurements made on pipe in stacks are not considered valid.
- Measurements shall be made on each end of a pipe, for 5% of the pipes produced but at least once per 4 hr per operating shift using a Hall-effect gauss-meter or other type of calibrated instrument. In case of dispute, measurements made with a Hall-effect gauss-meter shall govern. Measurements shall be made in accordance with a written procedure demonstrated to produce accurate results.
- Pipe magnetism shall be measured subsequent to any inspection that uses a magnetic field, prior to loading for shipment from the pipe mill.
- Four readings shall be taken 90° apart around the circumference of each end of the pipe.

530 The average of the four readings shall be less or equal to 2.0 mT (20 Gauss), and no single reading shall exceed 2.5 mT (25 Gauss). Any pipe that does not meet this requirement shall be considered defective.

531 All pipes produced between the defective pipe and the last acceptable pipe shall be individually measured unless the provisions of H530 can be applied.

532 If the pipe production sequence is documented, pipe may be measured in reverse sequence, beginning

with the pipe produced immediately prior to the defective pipe, until at least three consecutively produced pipes meet the requirements.

- Pipe produced prior to these three acceptable pipes need not be measured
- Pipe produced after the defective pipe shall be measured individually until at least three consecutive pipes meet the requirements.

533 All defective pipe shall be de-magnetized full length, and then their magnetism shall be re-measured until at least three consecutive pipes meet the requirements of H530.

534 For pipe handled with electromagnetic equipment after measurement of magnetism, such handling shall be performed in a manner demonstrated not to cause residual magnetism exceeding the acceptance criteria in H530.

535 The requirements for residual magnetism shall apply only to testing within the pipe mill since the residual magnetism in pipe may be affected by procedures and conditions imposed on the pipe during and after shipment.

H 600 Non-destructive testing of pipe ends not tested by automated NDT equipment

Untested pipe ends

601 When automated non-destructive testing equipment is used, a short area at both pipe ends will normally not be tested (see H410). Either the untested area of the pipe shall be cut off or the ends subjected to manual or automated NDT to the same extent as required for the full length of pipe

602 The methods, sensitivity and acceptance criteria for testing of untested ends shall be the same as used for retesting of pipes having signals equal to or greater than the threshold level from the automated non-destructive testing equipment.

603 The manufacturer shall prior to start of production present for acceptance the proposed extent, methods, sensitivity and acceptance criteria for testing of untested ends with reference to applicable procedures.

H 700 Non-destructive testing of pipe ends

General

701 These requirements apply to both seamless and welded pipe. Pipes not meeting the acceptance criteria below shall be deemed as “suspect pipe” according to H200 and shall be treated according to H300.

Testing of pipe ends for laminar imperfections

702 Both ends of each pipe shall be tested for laminar imperfections in accordance with ISO 10893-8 and the additional requirements in H400 over a band at least 50 mm inside the location of future welding preparations for girth welds.

703 If additional non-destructive testing is specified by the purchaser, the width of the band should be:

- at least 150 mm inside the location of future welding preparations for girth welds if automated ultrasonic testing of girth welds during installation will be performed
- at least 100 mm inside the location of future welding preparations for girth welds if allowance for re-bevelling of pipe shall be included.

704 Acceptance criteria are:

- according to Table D-12 or, if agreed, G203
- G300 for clad pipe.

Testing of end face or bevel for laminar imperfections

705 Magnetic particle testing or eddy current testing, manual or automated, of both end faces or bevels of each pipe in ferromagnetic steel for the detection of laminar imperfections shall be performed in accordance with the requirements in H400 and:

- ISO 10893-5 for magnetic particle testing
- ISO 10893-2 for eddy current testing.

706 Liquid penetrant or eddy current testing, manual or automated, of the end face or bevel of each pipe in non-ferromagnetic steel for the detection of laminar imperfections shall be performed in accordance with the requirements in H400 and:

- ISO 10893-4 for liquid penetrant testing
- ISO 10893-2 for eddy current testing.

707 The acceptance criterion is:

- Imperfections longer than 6 mm in the circumferential direction are not permitted.

H 800 Non-destructive testing of seamless pipe

Pipe ends

801 Pipe ends shall be tested as required by H600 and 700.

Ultrasonic inspection for laminar imperfections in the pipe body

802 Ultrasonic inspection of the pipe body shall be performed in accordance with the requirements in H400 and ISO 10893-8 amended as follows:

— the distance between adjacent scanning tracks shall be sufficiently small to ensure detection of the minimum allowed imperfection size.

803 The acceptance criteria are:

— according to Table D-12 or, if agreed, G203.

Ultrasonic inspection for longitudinal imperfections in the pipe body

804 Ultrasonic inspection of the pipe body shall be performed in accordance with the requirements in H400 and ISO 10893-10. The probe angles shall be chosen to obtain the best test result for the wall thickness/diameter ratio of the pipe to be tested.

For pipes in CRA materials it shall be verified that the presence of any possible coarse, anisotropic zones will not impede the testing, see H424 through H431.

805 The acceptance criterion is:

— Acceptance level U2/C according to ISO 10893-10.

Ultrasonic inspection for transverse imperfections in the pipe body

806 Ultrasonic inspection of the pipe body shall be performed in accordance with the requirements in H400 and ISO 10893-10. The probe angles shall be chosen to obtain the best test result for the wall thickness/diameter ratio of the pipe to be tested.

For pipes in CRA materials it shall be verified that the presence of any possible coarse, anisotropic zones will not impede the testing, see H424 through H431.

807 The acceptance criterion is:

— Acceptance level U2/C according to ISO 10893-10.

Ultrasonic thickness testing of the pipe body

808 Ultrasonic thickness testing of the pipe body shall be performed in accordance with the requirements in H400 and ISO 10893-12.

809 The acceptance criterion is:

— The specified maximum and minimum wall thickness shall be met.

Surface testing for longitudinal and transverse imperfections in the pipe body of ferromagnetic pipe

810 Testing of ferromagnetic seamless pipe for the detection of longitudinal and transverse surface imperfections shall be performed in accordance with the requirements in H400 and one of the following standards:

- ISO 10893-2 (eddy current testing)
- ISO 10893-3 (flux leakage testing)
- ISO 10893-5 (magnetic particle testing).

811 For detection of internal indications ISO 10893-2 or ISO 10893-3 shall be preferred provided adequate signal amplitudes from the internal surface reflector are documented and used for sensitivity setting.

812 The acceptance criteria are:

- ISO 10893-2: Alarm level/acceptance level E2
- ISO 10893-3: Alarm level/acceptance level F2
- ISO 10893-5: Alarm level/acceptance level Table 2, M2.

Surface testing for longitudinal and transverse indications in pipe body of non-magnetic pipe

813 Testing of non-magnetic seamless pipe for the detection of longitudinal and transverse surface imperfections shall be performed in accordance with the requirements in H400 and one of the following standards:

- ISO 10893-2 (eddy current testing)
- ISO 10893-4 (liquid penetrant testing).

814 For detection of internal indications ISO 10893-2 shall be preferred provided adequate signal amplitudes from the internal surface reflector are documented and used for sensitivity setting.

815 The acceptance criteria are:

- ISO 10893-2: Alarm level/acceptance level E2
- ISO 10893-4: Alarm level/acceptance level P2.

Suspect pipe

816 Pipes not meeting the acceptance criteria above shall be deemed as “suspect pipe” according to H200 and shall be treated according to H300.

H 900 Non-destructive testing of HFW pipe

Pipe ends

901 Pipe ends shall be tested as required by H600 and H700

Ultrasonic testing of the pipe body for detection of laminar imperfections

902 Ultrasonic testing of the pipe body for detection of laminar imperfections need not be performed at the pipe mill if testing of the coil edges was performed at the coil mill according to subsection G.

903 If performed at the pipe mill, ultrasonic testing of the pipe body for detection of laminar imperfections shall be performed in accordance with the requirements in H400 and ISO 10893-8 amended as follows:

- the distance between adjacent scanning tracks shall be sufficiently small to ensure detection of the minimum allowed imperfection size.

904 Acceptance criteria are:

- according to Table D-12 or, if agreed, G203.

Ultrasonic testing of the area adjacent to the weld seam for detection of laminar imperfections

905 Ultrasonic testing of the area adjacent to the weld seam body for detection of laminar imperfections shall be performed at the pipe mill if the strip is made by splitting of coil. If the strip is not made by splitting of coil and is tested for laminar imperfections at the coil mill according to subsection G, no testing for detection of laminar imperfections need to be performed at the pipe mill

906 If performed at the pipe mill, the testing shall be performed according to the requirements in H400 and ISO 10893-8.

907 Acceptance criteria are:

- according to Table D-12 or, if agreed G203.

Ultrasonic testing for longitudinal imperfections in the weld seam

908 Ultrasonic testing of the full length of the weld seam of HFW pipe for the detection of longitudinal imperfections shall be performed in accordance with the requirements in H400 and ISO 10893-11 with modifications as described in 909 through 918.

909 Accurate weld tracking with a tolerance ± 2 mm with respect to the centreline of the weld is essential due to the width of the weld.

910 The reference standard shall contain a typical weld, with the external flash removed and including tracks resulting from removal of the internal flash.

The reference reflectors shall be:

- external and internal reference notches located parallel to and in the centre of the weld. The notches shall be “N” type with a depth of 5% of the wall thickness notches with a depth of minimum 0.3 mm and maximum 1.2 mm.

911 One or more of the following probe configurations shall be used:

- Single pulse echo probes shall be selected such as the angle of incidence is as perpendicular to the radial centreline of the weld as possible.
- Tandem probes on each side of the weld with the angle of incidence as perpendicular to the radial centreline of the weld as possible.
- Probes alternating as transmitter-receiver with the angle of incidence as perpendicular to the radial centreline of the weld as possible.

The probe configuration shall provide a sufficient number of probes to cover the entire wall thickness from both sides of the weld.

912 The equipment shall include devices for weld tracking/ centering and provide checking of adequate

coupling for all probes.

913 Each probe shall be calibrated against the reference reflector located in the area of the weld to be covered by that probe.

914 For single pulse echo probes and tandem probes the threshold settings shall be as follows:

- If the testing is performed with one probe pair covering the entire wall thickness, the response from the intersections between the reference notches and the external and internal pipe surface shall be optimised and the threshold level set at 80% of full screen height of the lowest of the obtained responses.
- If the testing is performed with probe pairs each covering a part of the wall thickness, the threshold level shall be set at 80% of full screen height.

915 For probes alternating as transmitter-receiver the threshold level shall be set corresponding to a loss of 75% of the transmitted signal.

916 For each probe, the following shall be recorded:

- type, frequency, angle and dimension
- the distance from the index point to the weld centreline
- the angle between the ultrasound direction and the major pipe axis.
- amplitudes and gain settings.

917 Gates shall be set such that reflections from the tracks resulting from removal of the internal flash are avoided but sufficiently wide to ensure that the tolerances in the weld tracking system will result in responses from indications inside the weld and the HAZ.

918 The settings for lack of coupling alarm shall be set and checked.

919 The acceptance criterion is:

- Pipes producing signals below the threshold shall be deemed to have passed the test.

Plate/strip end welds

920 Testing of plate/strip end welds (when such welds are allowed) shall, unless otherwise agreed be performed by ultrasonic testing according to this standard. The testing shall comply with the requirements of this standard and methods and a set-up suitable for the applied welding method shall be used.

Suspect pipe

921 Pipes not meeting the acceptance criteria above shall be deemed as “suspect pipe” according to H200 and shall be treated according to H300.

H 1000 Non-destructive testing of CRA liner pipe

1001 Testing of CRA pipe for the detection of longitudinal and transverse surface imperfections and the longitudinal weld shall be performed in accordance with the requirements in H400 and ISO 10893-2 (eddy current testing).

- The acceptance criterion for eddy current testing is:
- The response shall not exceed half the response of alarm level/acceptance level E2 according to ISO 10893-2.

1002 Testing of the weld seam can alternatively be performed in accordance with the requirements in H400 and ISO 10893-6 (radiographic testing). Digital radiography testing, if applicable, shall be performed in accordance with ISO 10893-7, class B.

1003 The acceptance criteria for radiographic testing are:

- No cracks, lack of fusion, lack of penetration or pore clusters. Individual circular imperfections shall not exceed 1.5 mm or $\frac{1}{4} t$, whichever is smaller. Accumulated diameters of permitted imperfections shall not exceed 3 mm or $\frac{1}{2} t$, whichever is smaller. No other discernable indications are allowed.

Untested pipe ends

1004 Untested pipe ends shall be tested as required by H600.

Suspect pipe

1005 Pipes not meeting the acceptance criteria above shall be deemed as “suspect pipe” according to H200 and shall be treated according to H300.

H 1100 Non-destructive testing of lined pipe

Non-destructive testing of the backing pipe

1101 Non-destructive testing of the outer C-Mn steel backing pipe shall be performed prior to insertion of the CRA liner pipe. The backing pipe shall be subjected to the same testing with the same acceptance criteria that are required in this Appendix for the type of backing pipe used.

Pipe ends

1102 After insertion of the liner pipe and performing seal and/or clad welding the ends of lined pipe shall be tested for laminar imperfections in accordance with the requirements in H400 and ISO 10893-8 or ASTM A578 S7 in a band at each pipe end. For clad welded pipe ends this includes testing for bonding defects. The band shall be sufficiently wide to cover the width of the seal/clad weld between the C-Mn steel backing pipe and the CRA liner pipe. Manual or automated methods may be used.

1103 The acceptance criterion is:

- No indications are allowed within the tested areas.

Seal and clad welds

1104 The seal and/or clad welds at pipe ends shall be subject to manual liquid penetrant testing according to B600 or eddy current testing according to B700.

1105 The acceptance criteria are:

- No round indications with diameter above 1 mm and no elongated indications.
- Indications separated by a distance less than the diameter or length of the smallest indication, shall be considered as one indication.
- Accumulated diameters of round indications in any 100 mm length of weld shall not exceed 6 mm.

H 1200 Non-destructive testing of clad pipe

Pipe ends

1201 Pipe ends shall be tested as required by H600 and H700.

Ultrasonic testing of the pipe body for detection of laminar imperfections

1202 Ultrasonic testing of the pipe body for detection of laminar imperfections in the backing pipe need not be performed at the pipe mill if testing of the plate was performed at the plate mill according to subsection G.

1203 If performed at the pipe mill, ultrasonic testing of the pipe body for detection of laminar imperfections shall be performed in accordance with the requirements in H400 and ISO 10893-8 amended as follows:

- The distance between adjacent scanning tracks shall be sufficiently small to ensure detection of the minimum allowed imperfection size.

1204 Acceptance criteria are:

- according to Table D-12 or, if agreed, G203.

1205 Ultrasonic testing of the pipe body for detection of lack of bond between the cladding and backing pipe shall be performed in accordance with the requirements in H400 and ASTM 578 S7 amended as follows:

- The distance between adjacent scanning tracks shall be sufficiently small to ensure detection of the minimum allowed imperfection size.

1206 The acceptance criterion is:

- ASTM A578 - S7. In addition, no areas with laminations or lack of bond are allowed in the plate edge areas.

Ultrasonic testing for longitudinal and transverse imperfections in the weld seam

1207 For ultrasonic testing of the CRA part of the weld seam it must be demonstrated that low frequency shear wave angle probes are adequate for detection as required in H424 through H431. If it is not possible to demonstrate adequate performance of low frequency shear wave angle probes other methods or combination of methods shall be used and the adequacy of the methodology demonstrated.

Ultrasonic testing of the weld seam of clad pipe for the detection of longitudinal and transverse imperfections, when demonstrated to give acceptable results, shall be in accordance with the requirements in H400 and ISO 10893-11 with modifications as described in 1208 through 1219.

1208 The reference standard shall contain a typical production weld. The weld surface shall be ground flush with the original pipe contour in an area around each reference reflector sufficient to obtain signals without interference from un-ground weld reinforcements.

1209 The reference reflectors shall be:

- One 1.6 mm diameter through-drilled hole at the weld centreline for detection of transverse indications.
- Longitudinal external and internal notches on both sides, parallel and adjacent to the weld seam for detection of longitudinal imperfections outside the root area. The notch shall be the “N” type with 5% of the wall thickness, but not more than 1.5 mm or less than 0.3 mm.
- One notch on each side of the internal weld cap located immediately adjacent to and parallel with the weld for detection of longitudinal imperfections in the root area. The notch shall be the “N” type with 3% of the

wall thickness, but not more than 1.2 mm or less than 0.3 mm.

- If agreed, the reference reflectors for detection of transverse imperfections can be internal and external notches, “N” type with 3% of the wall thickness, positioned at right angles to, and centred over, the weld seam.
- Additional reflectors may be used to define the weld extremities and aiding in the gate settings. The use, type and numbers of such reflectors shall be at the manufacturer’s option.

The length of the notches shall be 1.5 times the probe (crystal) element size or 20 mm, whichever is shorter. The length does not include any rounded corners. The width of the notches shall not exceed 1 mm.

1210 The probe angles shall be chosen to obtain the best possible test result for wall thickness and diameter of the pipe to be tested. The probe angle shall be chosen such that the angle of incidence is as perpendicular as possible to the weld bevel in the area covered by the probe.

1211 The frequency of the probes used in the root area shall be as low as possible and not above 2 MHz.

1212 The probe configuration for detection of the longitudinal indications shall provide a sufficient number of opposing probe pairs to cover the entire wall thickness. E.g. one pair of probes for the external and internal N5 notches and one pair for the internal N3 notches in the root area.

1213 The probe configuration for detection of transverse indications shall be two wide beam, opposing probes travelling “on bead”. An X type configuration of the probes for detection of transverse indications may be used, subject to agreement.

1214 The gates shall be set wide enough to compensate for:

- The tolerances of weld tracking system
- Variations in the width of external and internal caps
- Offsets between the external and internal weld bead.

1215 Each probe shall be calibrated against the reference reflector located in the area of the weld to be covered by that probe. The response from the reference reflectors shall be optimised for each probe and probe pair:

- For detection of longitudinal imperfections in the root area the optimised response for each probe shall be obtained from the internal notch on the opposite side of the weld. The threshold level for each of the internal notches shall be set no higher than 50% of full screen height from the maximised response.
- For detection of longitudinal imperfections outside the root area the response from the external and internal notches shall optimised and the threshold level set to 80% of full screen height for each of the maximised responses.
- For detection of transverse imperfections the threshold level for the 1.6 mm through drilled hole or transverse notches shall be set no higher than 80% of full screen height.
- If the use of transverse notches is agreed for detection of transverse indications, the response from the external and internal notches shall optimised and the threshold level set to 80% of full screen height for each of the maximised responses.
- The additional reflectors allowed in 1209 shall not be used for threshold settings.

1216 For each probe, the following shall be recorded:

- type, frequency, angle and dimension
- the distance from the index point to the weld centreline
- the angle between the ultrasound direction and the major pipe axis
- amplitudes and gain settings.

1217 Gates shall be set such that reflections from the weld caps are avoided but sufficiently wide to ensure that, with the given tolerances of the weld tracking system, responses are obtained from indications located inside the weld and the HAZ.

1218 The settings for lack of coupling alarm shall be set and checked.

1219 The acceptance criterion when using shear wave probes is:

- Pipes producing signals below the threshold shall be deemed to have passed the test.

When compression wave angle probes are used, other types of reflectors shall be used and the acceptance criteria shall be specified and agreed accordingly.

Ultrasonic testing of the area adjacent to the weld seam for detection of laminar imperfections

1220 Ultrasonic testing of the area adjacent to the weld seam body for detection of laminar imperfections need not be performed at the pipe mill if testing of the plate edges was performed at the plate mill according to subsection G.

1221 If performed at the pipe mill, the testing shall be performed according to the requirements in H400 and ISO 10893-8.

1222 Acceptance criteria are:

- according to Table D-12 or, if agreed, G203.

Testing for the detection of surface imperfections in the weld area

1223 Testing for the detection of longitudinal and transverse surface imperfections in the weld area shall be performed in accordance with the requirements in H400 and one of the following standards:

- ISO 10893-2 (eddy current testing)
- ISO 10893-3 (flux leakage testing)
- ISO 10893-5 (magnetic particle testing).

1224 The acceptance criteria are:

- ISO 10893-2: Alarm level/acceptance level E2
- ISO 10893-3: Alarm level/acceptance level F2
- ISO 10893-5: Alarm level/acceptance level Table 3, M2.

Radiographic testing of welds

1225 Full length radiographic testing of the weld shall be performed in accordance with the requirements in H400 and ISO 10893-6.

1226 For pipe subject to full length ultrasonic testing of the weld, radiographic testing of the weld at each pipe end shall include the area not covered by the automated ultrasonic testing and shall at least cover a weld length of 300 mm. The testing shall be performed in accordance with the requirements in H400 and ISO 10893-6. For digital radiographic systems, reference is made to clause H433.

1227 The acceptance criteria are:

- according to ISO 10893-6 or ISO 10893-7.

Suspect pipe

1228 Pipes not meeting the acceptance criteria above shall be deemed as “suspect pipe” according to H200 and shall be treated according to H300.

H 1300 Non-destructive testing of SAWL and SAWH pipe

Pipe ends

1301 Pipe ends shall be tested as required by H600 and H700.

Ultrasonic testing of the pipe body for detection of laminar imperfections

1302 Ultrasonic testing of the pipe body for detection of laminar imperfections need not be performed at the pipe mill if testing of the plate/coil edges was performed at the plate/coil mill according to subsection G.

1303 If performed at the pipe mill, ultrasonic testing of the pipe body for detection of laminar imperfections shall be performed in accordance with the requirements in H400 and ISO 10893-8 amended as follows:

- the distance between adjacent scanning tracks shall be sufficiently small to ensure detection of the minimum allowed imperfection size.

1304 Acceptance criteria are:

- according to Table D-12 or, if agreed, G203.

Ultrasonic testing of the area adjacent to the weld seam for detection of laminar imperfections

1305 Ultrasonic testing of the area adjacent to the weld seam body for detection of laminar imperfections need not be performed at the pipe mill if testing of the plate/coil edges was performed at the plate/coil mill according to subsection G.

1306 If performed at the pipe mill, the testing shall be performed according to the requirements in H400 and ISO 10893-8.

1307 Acceptance criteria are:

- according to Table D-12 or, if agreed, G203.

Ultrasonic testing for longitudinal and transverse imperfections in the weld seam

1308 Ultrasonic testing of the weld seam of SAW pipe for the detection of longitudinal and transverse imperfections shall be in accordance with the requirements in H400 and ISO 10893-11 with modifications as given in 1309 through 1320.

The equipment shall allow for the complete examination of the weld and its adjacent area for both longitudinal

and transverse defects. The equipment shall be fitted with an automatic paint spray system (or alternative system, e.g. recording) for marking the areas giving ultrasonic indications and areas where a loss of ultrasonic coupling with the pipe has occurred.

To verify that no defects originating from hydrogen is present, a minimum of 2% of the pipes shall be examined by an optimized manual UT procedure for cracks. This investigation shall be done minimum 48 hours after welding. If pipe contains such defects all pipes produced prior to this pipe and the last tested shall be quarantined.

1309 The reference standard shall contain a typical production weld. The weld surface shall be ground flush with the original pipe contour in an area around reference reflectors used for setting inspection sensitivity for the inspection of longitudinal imperfections in order to obtain signals without interference from un-ground weld reinforcements. The weld surface shall stay unground in the area of reference reflector for setting sensitivity on for the inspection of transverse imperfections.

1310 The reference reflectors shall be:

- One 1.6 mm diameter through drilled hole at the weld centreline for detection of transverse indications
- Longitudinal external and internal notches on both sides, parallel and adjacent to the weld seam for detection of longitudinal imperfections. The notch shall be the “N” type with 5% of the wall thickness, but not more than 1.5 mm or less than 0.3 mm. The length of the notches shall be 1.5 times the probe (crystal) element size or 20 mm, whichever is shorter. The length does not include any rounded corners. The width of the notches shall not exceed 1 mm.
- For wall thickness ≥ 19 mm a longitudinal reference reflector, e.g. a side-drilled hole, shall be located at mid thickness of the weld and parallel to the weld. This reflector shall provide a return signal comparable to that from a N5 notch. The Manufacturer shall propose a type of reflector suitable for the purpose, and the type of reflector used is subject to agreement.
- If agreed, the reference reflectors for detection of transverse imperfections can be internal and external notches, positioned at right angles to, and centred over, the weld seam.
- Additional reflectors may be used to define the weld extremities and aiding in the gate settings. The use, type and numbers of such reflectors shall be at the manufacturer’s option and shall be described in the documented procedure.

1311 The inspection angles shall be chosen to obtain the best possible test result for wall thickness and diameter of the pipe to be tested. The inspection angle should be chosen such that the angle of incidence is as perpendicular as possible to the weld bevel in the area covered by the probe.

1312 The probe configuration for detection of the longitudinal indications shall provide a sufficient number of opposing probe pairs or focal laws to cover the entire wall thickness. Each reference reflector shall have a dedicated probe pair/focal law.

1313 The probe configuration for detection of transverse indications shall be two wide beam, opposing probes travelling “on bead”. An X type configuration of the probes for detection of transverse indications may be used instead of wide beam probes “on bead”, subject to agreement.

1314 Each probe or focal law shall be calibrated against the reference reflector located in the area of the weld to be covered by that probe. The response from the reference reflectors shall be optimised for each probe and probe pair:

- For detection of longitudinal imperfections the optimised response from the longitudinal external and internal notches shall be set to 80% of full screen height for each of the obtained responses. The rejection threshold shall be set to no higher than 80% full screen height.
- If a separate reflector is positioned at mid thickness, for instance a side drilled hole, the optimised response from this reflector shall be set to 80% of full screen height for each of the obtained responses. The rejection threshold shall be set to no higher than 80% full screen height.
- For detection of transverse imperfections the optimised response from the 1.6 mm through drilled hole or transverse notches shall be set no higher than 80% of full screen height. The rejection threshold shall be set to no higher than 80% full screen height.
- If the use of transverse notches is agreed for detection of transverse imperfections, the response from the transverse external and internal notches shall be optimised and set to 80% of full screen height for each of the obtained responses. The rejection threshold shall be set to no higher than 80% full screen height.
- The additional reflectors allowed in 1310 shall not be used for threshold settings.

For each probe or focal law, the following shall be recorded:

- type, frequency, angle and dimension
- the distance from the index point to the weld centreline
- the angle between the ultrasound direction and the major pipe axis
- amplitudes and gain settings.

The following parameters shall be reported and a print out shall be made available at the AUT station:

- A comprehensive detailed list of probes/channels, longitudinal/transverse, ID/OD/Mid, flaw detection/coupling.
- A matrix showing all channels including coupling channels, with response from the different reflectors including calibration reflectors shall be made with dB levels, gain, signal height, trigger threshold. The table “channels/reflectors (C/R)”, shall be included in the AUT procedure/working instructions and submitted to COMPANY for approval.
- Date, time, operator name and signature, inspector name and signature.

1315 The gates shall be set wide enough to compensate for:

- the tolerances of weld tracking system
- variations in the width of external and internal caps
- offsets between the external and internal weld bead.

1316 The settings for lack of coupling alarm shall be set and checked.

1317 When the settings are optimised, the relevant parameters shall be recorded and the reference standard shall be passed 3 times through the equipment at the operational velocity. Any change in settings required to maintain the static mode settings shall be recorded as an average of the 3 runs. For acceptance of the settings, the deviation in response from each calibration reflector shall not be more than 3 dB from the primary reference level (80% FSH). Gate settings shall not deviate more than 2.5 mm from the reference position.

One dynamic calibration verification scan of the reference standard shall be carried out at the start of each shift, whenever there is an equipment change over, whenever there is an operator change, after every 10 pipe tested or every 4 hours, whichever is the first event met.

1318 The acceptance criterion is:

Pipes producing signals below the rejection threshold shall be deemed to have passed the test.

Additional requirements for SAWH pipe strip/plate end welds

1319 For SAWH pipe the full length of strip/plate end welds (when such welds are allowed) shall be ultrasonically tested as required above for the helical seam. Alternatively manual ultrasonic testing in accordance with Subsection H1400 may be used for testing of test strip/plate end welds.

In addition, the joints where the extremities of the helical and strip/plate end welds meet shall be subject to radiographic testing in accordance with the requirements in H400 and ISO ISO 10893-6. For use of digital radiographic equipment, reference is made to clause H433.

1320 Acceptance criteria for these tests are:

- For automated ultrasonic testing: according to H1319 above
- For manual ultrasonic testing: according to H1400
- For radiographic testing: According to ISO 10893-6.

Additional requirements for testing of SAW CRA pipes and welds with CRA weld deposits

1321 Ultrasonic testing of welds in CRA materials with CRA (duplex, other stainless steels and nickel alloy steel) weld deposits will, in order to achieve an adequate detection of imperfections, normally require that special reference blocks and probes are used.

1322 The requirements given in H424 through H431 shall be fulfilled and special reference is made to H430 and H431.

1323 When compression wave angle probes are used, other types of reflectors shall be used and the acceptance criteria specified accordingly.

Testing of ferromagnetic pipe for the detection of surface imperfections in the weld area

1324 Testing of ferromagnetic pipe for the detection of longitudinal and transverse surface imperfections shall be performed in accordance with the requirements in H400 and one of the following standards:

- ISO 10893-2 (eddy current testing)
- ISO 10893-3 (flux leakage testing)
- ISO 10893-5 (magnetic particle testing).

The acceptance criteria are:

- ISO 10893-2: Alarm level/acceptance level E2
- ISO 10893-3: Alarm level/acceptance level F2
- ISO 10893-5: Alarm level/acceptance level Table 3, M2.

Testing of non magnetic pipe for the detection of surface imperfections in the weld area

1325 Testing of non-magnetic SAW pipe for the detection of longitudinal and transverse surface imperfections shall be performed in accordance with the requirements in H400 and one of the following standards:

- ISO 10893-2 (eddy current testing)
- ISO 10893-4 (liquid penetrant testing).

The acceptance criteria are:

- ISO 10893-2: Acceptance level E2
- ISO 10893-4: Acceptance level P2.

Radiographic testing

1326 Radiographic testing of the weld at each pipe end shall include the area not covered by the automated ultrasonic testing and shall at least cover a weld length of 300 mm. The testing shall be performed in accordance with the requirements in H400 and ISO 10893-6.

The acceptance criteria are:

- according to ISO 10893-6.

Suspect pipe

1327 Pipes not meeting the acceptance criteria above shall be deemed as “suspect pipe” according to H200 and shall be treated according to H300.

H 1400 Manual NDT at pipe mills

General

1401 In all cases when the automated NDT system give signals equal to or greater than the threshold level, or surface imperfections are disclosed by visual examination, manual NDT may be performed in order to confirm the presence or absence of a defect. Automated or semi-automated NDT may be used as substitution of the manual NDT required in H1400 provided the method is demonstrated to provide the same or better sensitivity in detection of imperfections.

1402 In addition, manual NDT may be performed on pipe ends that are not tested by the automated equipment. See H600.

1403 The requirements in H1400 are only applicable to manual NDT performed at pipe mills only.

Radiographic testing

1404 Radiographic testing shall be performed in accordance with the requirements in H400 and ISO 10893-6 to cover the full weld length or to supplement other NDT methods when the type of or severity of an indication in weld can not be determined with certainty.

The acceptance criteria are:

- according to ISO 10893-6.

All pipe; manual ultrasonic testing for laminar imperfections and thickness testing

1405 Manual ultrasonic thickness testing and testing for laminar imperfections shall be performed on untested pipe ends and to confirm the presence or absence of a defect when automated NDT systems gives signals equal to or greater than the threshold level.

Manual ultrasonic testing of pipe ends, laminar imperfections

1406 Any additional non-destructive testing shall be as specified by the purchaser.

1407 If automated ultrasonic testing of girth welds during installation will be performed the width of the band should extend at least 150 mm inside the location of future welding preparations for girth welds.

1408 If allowance for re-bevelling of pipe shall be included, the width of the band should extend at least 100 mm inside the location of future welding preparations for girth welds.

1409 Acceptance criteria are:

- according to Table D-12 or, if agreed, G203.

Manual ultrasonic testing of pipe ends, radial cracks

1410 For detection of cracks angle probes shall be used to supplement the straight beam probes. Testing shall be in general accordance with ASTM A577 or equivalent standard and:

- Probes shall meet the requirements of C203.

- Sensitivity for C-Mn steel shall be a DAC curve based on reference blocks with a rectangular notch with depth 3% of the material thickness on both sides.
- Reference blocks for duplex stainless steel and austenitic steels shall have one Ø 3 mm flat bottom hole perpendicular to the angle of incidence of the probe and at the largest possible depth from the scanning surface of the block. Reference blocks shall be of the actual material tested or of a material with similar with acoustic properties.
- Low frequency shear wave angle probes may be used for CRA material instead of twin crystal (transmitter/receiver) compression-wave probes. For acceptance, it shall be verified on the reference blocks that it is possible to obtain a DAC with a shear wave angle probe that is comparable to the DAC obtained with an angle compression wave probe.

1411 The acceptance criterion is:

- no indications shall exceed the DAC.

Manual ultrasonic testing of the pipe body for detection of laminar imperfections

1412 Manual ultrasonic testing of the pipe body for detection of laminar imperfections need not be performed at the pipe mill if testing of the plate/coil edges was performed at the plate/coil mill according to subsection G.

1413 If performed at the pipe mill, manual ultrasonic testing of the pipe body for detection of laminar imperfections shall be performed in accordance ISO 10893-8, App.A amended as follows:

- the distance between adjacent scanning tracks shall be sufficiently small to ensure detection of the minimum allowed imperfection size.

1414 Acceptance criteria are:

- according to Table D-12 or, if agreed, G203.

Manual ultrasonic testing of the area adjacent to the weld seam for detection of laminar imperfections

1415 Manual ultrasonic testing of the area adjacent to the weld seam body for detection of laminar imperfections need not be performed at the pipe mill if testing of the plate/coil edges was performed at the plate/coil mill according to Subsection G.

1416 If performed at the pipe mill, the manual NDT shall be performed according to ISO 10893-8, App.A.

1417 Acceptance criteria are:

- according to Table D-12 or, if agreed, G203.

Manual ultrasonic thickness testing of the pipe body

1418 Manual ultrasonic thickness testing of the pipe body shall be performed in accordance with the requirements ISO 10893-12.

1419 The acceptance criterion is:

- the specified maximum and minimum wall thickness shall be met.

Seamless pipe; manual ultrasonic testing for longitudinal and transverse imperfections

1420 Manual ultrasonic testing and testing of seamless pipe for longitudinal and transverse imperfections shall performed on untested pipe ends and to confirm the presence or absence of a defect when automated NDT systems gives signals equal to or greater than the threshold level.

1421 For pipes in CRA materials it shall be verified that the presence of any possible coarse, anisotropic zones will not impede the testing, see H424 through H431.

1422 Manual ultrasonic testing of the pipe body for longitudinal imperfections shall be performed in accordance with ISO 10893-10. The probe angles shall be chosen to obtain the best test result for the wall thickness/diameter ratio of the pipe to be tested.

The acceptance criterion is:

- acceptance level U2/C according to ISO 10893-10.

1423 Manual ultrasonic inspection of the pipe body for transverse imperfections shall be performed in accordance with the requirements in ISO 10893-10. The probe angles shall be chosen to obtain the best test result for the wall thickness/diameter ratio of the pipe to be tested.

The acceptance criterion is:

- acceptance level U2/C according to ISO 10893-10.

Welded pipe; manual ultrasonic testing of welds

1424 Manual ultrasonic testing and testing of welds in welded pipe for longitudinal and transverse imperfections shall be performed on untested pipe ends and to confirm the presence or absence of a defect when automated NDT systems gives signals equal to or greater than the threshold level.

1425 Manual ultrasonic testing of welds in C-Mn steel material with C-Mn steel weld deposits shall be performed in accordance with B300 except that B314, B317, B321, B322 and B338 shall not apply.

Manual ultrasonic testing of welds in HFW pipe

1426 The reference block shall be according to H910.

1427 One or more of the following probe configurations shall be used:

- Single pulse echo probes with the angle of incidence as perpendicular to the radial centreline of the weld as possible.
- Tandem probes with the angle of incidence as perpendicular to the radial centreline of the weld as possible.

1428 The probe angle for the initial scanning shall be chosen to obtain the best possible test result for wall thickness and diameter of the pipe to be tested and such that the angle of incidence is as perpendicular as possible to the weld bevel.

1429 The DAC shall be constructed using the notches in the reference block. A 2-point DAC shall only be used if scanning is limited to one full skip or less. If scanning is performed using more than one full skip, a 3-point DAC shall be established as a minimum.

1430 The acceptance criterion is:

- no maximised echo from any probe shall exceed the DAC.

Manual ultrasonic testing of welds in CRA materials and in clad pipe

1431 Ultrasonic testing of welds in CRA materials with CRA (duplex, other stainless steels and nickel alloy steel) weld deposits will in order to achieve an adequate detection of imperfections normally require that special reference blocks and probes are used for testing of these materials. Unless it can be demonstrated as required in B418 and H429 that use of low frequency shear wave angle probes gives acceptable detection, manual ultrasonic testing of the CRA weld deposit in the root shall be performed as required in B400

1432 Angle beam probes shall be available in angles, or be provided with wedges or shoes, ranging from 30° to 75°, measured to the perpendicular of the surface of the pipe being tested. Probe angles shall be selected as required in B300. The probe angles shall be chosen to obtain the best possible test result for wall thickness and diameter of the pipe to be tested and such that the angle of incidence is as perpendicular as possible to the weld bevel in the area covered by the probe. If shear wave angle probes are used for testing of the root the frequency shall be 2 MHz or lower.

1433 The reference standard for testing with shear angle probes shall be according to H1208 and H1209.

Testing sensitivities shall be established as follows:

- For testing of longitudinal imperfections in the weld volume outside the root area, the DAC shall be constructed using the longitudinal external and internal notches. A 2-point DAC shall only be used if scanning is limited to one full skip or less. If scanning is performed using more than one full skip, a 3-point DAC shall be established as a minimum.
- For testing of the root area longitudinal imperfections sensitivity setting shall be against the notch in the root area on the opposite side of the weld and the response set to 50% of full screen height.
- For testing of transverse imperfections, the DAC shall be constructed using the 1.6 mm diameter through drilled holes at the weld centreline with 2 points (e.g. ½ and full skip).

1434 Scanning for transverse indications shall be performed “on bead”. Probes with beam angles of 45° and 60° shall be available.

1435 The acceptance criteria are:

- No maximised indications exceeding DAC for longitudinal and transverse indications.
- No maximised indications in the root area exceeding 50% of full screen height.

When compression wave angle probes are used, other types of reflectors are used and the acceptance criteria shall be specified and agreed accordingly.

Manual ultrasonic testing of welds in SAWL and SAWH pipe

1436 The reference standard shall be according to H1309 and H1310.

1437 Angle beam probes shall be available in angles, or be provided with wedges or shoes, ranging from 30° to 75°, measured to the perpendicular of the surface of the pipe being tested. Probe angles shall be selected as required in B300.

1438 Testing sensitivities shall be established as follows:

- For testing of longitudinal imperfections in the weld volume, the DAC shall be constructed using the longitudinal external and internal notches. A 2-point DAC shall only be used if scanning is limited to one full skip or less. If scanning is performed using more than one full skip, a 3-point DAC shall be established as a minimum
- For testing of transverse imperfections, the DAC shall be constructed using the 1.6 mm diameter through drilled holes at the weld centreline with 2 points (e.g. ½ and full skip).

1439 Scanning for transverse indications shall be performed “on bead”. Probes with beam angles of 45° and 60° shall be available. Use of 4 MHz probes shall be preferred.

1440 Acceptance criterion is:

- no maximised indications exceeding DAC

Manual ultrasonic testing of welds in CRA materials and CRA weld deposits/materials.

1441 Refer to H424 through H431. Ultrasonic testing of CRA materials and welds with CRA (duplex, other stainless steels and nickel alloy steel) weld deposits will in order to achieve an adequate detection of imperfections require that special calibration blocks and probes are used for testing of welds in these materials. Angle probes generating compression waves should be used in addition to straight beam probes, angle shear wave probes and creep wave probes.

1442 Unless it can be demonstrated as required in B418 and H429 that use of low frequency shear wave angle probes only gives acceptable detection, manual ultrasonic testing of CRA materials and welds with CRA weld deposits shall be performed as required in B400.

1443 Acceptance criteria manual ultrasonic testing of CRA materials and welds with CRA weld deposits performed with angle compression wave probes are:

- according to Table D-6.

Manual magnetic particle testing

1444 Manual magnetic particle surface testing shall be performed in accordance with B500 and ISO 10893-5.

1445 Manual magnetic particle testing of pipe ends shall be performed in accordance with B500 and ISO 10893-5.

1446 Manual magnetic particle testing of welds shall be performed as required by B500.

1447 Acceptance criteria shall be according to the relevant requirements of this subsection.

Manual liquid penetrant testing

1448 Manual liquid penetrant surface testing and testing of pipe ends shall be performed in accordance with ISO 10893-4.

1449 Manual liquid penetrant testing of welds shall be performed in accordance with B600, paragraphs 602 through 605.

1450 Acceptance criteria shall be according to the relevant requirements of this subsection.

Manual eddy current testing

1451 Manual eddy current surface testing and testing of pipe ends shall be performed in accordance with ISO 10893-2.

1452 Manual eddy current testing of welds shall be performed in accordance with B700, paragraphs 702 through 708 and ISO 10893-2 (eddy current testing)

1453 Acceptance criteria shall be according to the relevant requirements of this subsection.

H 1500 Non-destructive testing of weld repair in pipe

1501 Weld repair of the body of any pipe and of the weld in HFW pipe is not permitted.

1502 A repaired weld shall be completely re-tested using applicable NDT methods in accordance with H800 through 1300.

Alternatively, manual NDT may be performed in accordance with H1400 and with acceptance criteria in accordance with the requirements in H1400. In this case, manual ultrasonic testing shall be governing for embedded defects.

APPENDIX E

AUTOMATED ULTRASONIC GIRTH WELD TESTING

A. General

A 100 Objective

101 This Appendix details the examination requirements for the automated ultrasonic testing of pipeline girth welds.

A 200 Applicability

201 The Appendix applies when automated ultrasonic testing (AUT) is performed on pipeline girth welds.

A 300 References

- a) American Society for Testing Materials - E 317-94: Standard Practice for Evaluating Performance Characteristics of Pulse Echo Testing Systems Without the Use of Electronic Measurement Instruments
- b) EN12668-1 Non destructive testing - Characterisation and verification of ultrasonic examination equipment- Part 1: Instruments
- c) EN12668-2 Non destructive testing - Characterisation and verification of ultrasonic examination equipment- Part 2: Transducers
- d) EN12668-3 Non destructive testing - Characterisation and verification of ultrasonic examination equipment- Part: 3: Combined equipment
- e) EN583-6 Non destructive testing - Ultrasonic examination Part 6 - Time-of-flight diffraction as a method for defect detection and sizing
- f) DNV-RP-F118 Pipe Girth Weld AUT System Qualification and Project Specific Procedure Validation

B. Basic Requirements

B 100 General

101 The primary requirement to any AUT system is that its performance is documented in terms of adequate detection and sizing, or rejection abilities, in relation to specified / determined acceptable defects. The performance of the AUT system has through the qualification to be demonstrated to meet or exceed the requirements in terms of detection or rejection set by the applicable acceptance criteria for any project.

102 The ultrasonic system to be used shall be accepted through qualification, see Subsection H.

103 The ultrasonic system may use pulse echo, tandem, time-of-flight diffraction (TOFD) and/or through transmission techniques employing either fixed or phased arrays. It shall have a fully automatic recording system to indicate the location of defects and the integrity of acoustic coupling. A zonal approach shall be combined with root and weld volume mapping channels, and preferably TOFD. The zonal concept may be deviated from. This requires an adequate technical description of the alternative approach, and a system qualification according to Subsection H.

104 The information provided by all AUT channel types shall be actively used in order to ensure adequate defect detection and sizing.

105 The ultrasonic system may include scanner heads and system set-up specifically configured for testing of repairs where the primary function is to confirm the complete removal of rejected flaw. As a minimum the AUT system with its normal set-up, but with gates wide enough to encompass the repair area and confirm that the AUT defects have been removed. During this special attention shall also be made to TOFD channel indications, and indications outside the normal gate settings.

Due to the wide variation in repair weld groove shapes that may limit the detection capabilities of the system, manual UT, or a dedicated semi-automatic UT system, shall support the AUT on weld repairs unless the groove shape is controlled to be within given tolerances and the scanner head is configured accordingly. For supplementary UT, the provisions of Appendix D apply.

106 The ultrasonic system shall incorporate facilities for detection of transverse defects, when it is clearly identified that the weld process, parent material, application and environmental condition may increase the risk for transversal type flaws.

107 For AUT, allowable wall thickness variations from nominal thickness is ± 1.5 mm applicable for pipes exposed for a total nominal strain of less than 0.4%, and ± 1.0 mm applicable for total nominal strains equal to and above 0.4%. For variations from nominal wall thickness outside this, additional validations or qualification tests are required. These tests shall reflect the total expected wall thickness variation, and provide evidence of 100% coverage of the fusion face and the root area.

108 Counter bores may be used to compensate for large thickness variations if the counter bore is machined to provide parallel external and internal surfaces before the start of the taper. The length of the parallel surfaces shall at least be sufficient to allow scanning from the external surface and sufficient for the required reflection off the parallel internal surface.

109 Weld deposits in duplex, austenitic stainless steels and nickel alloys have a coarse grain structure with variations in grain size and structure resulting in unpredictable fluctuations in attenuation. Duplex and austenitic stainless steel base materials will have the same characteristics. Ultrasonic testing of welds with CRA (duplex, other stainless steels and nickel alloy steel) weld deposits will in order to achieve an adequate detection of imperfections require that special calibration blocks and transducers are used for testing of welds in these materials.

110 An operating Quality Assurance system shall be used covering the development of ultrasonic examination systems, testing, verification and documentation of the system and its components and software against given requirements, qualification of personnel and operation of ultrasonic examination systems. The Quality Assurance system employed shall be documented in sufficient detail to ensure that AUT systems used for field inspection will be designed, assembled and operated within the essential variables established during the qualification and in all significant aspects will be equal to the qualified AUT system. ISO 9000 and ASTM E 1212 shall apply as basic requirements to the Quality Assurance system.

The following shall be documented:

- document control
- system development including establishing performance
- requirements to the system, its components and calibration blocks
- selection/qualification/follow-up/auditing of suppliers/subcontractors
- procurement of system components and calibration blocks
- verification of delivered system components and calibration blocks against given requirements
- marking/identification of system components and calibration blocks complying with given requirements
- control and verification of software development/changes
- design of AUT system(s) set-up for specific field operation conditions/requirements
- assembly of AUT systems for field operation from verified components in stock, including identification of the system and identification/documentation of its components, calibration block(s) and spare parts
- verification/testing of AUT systems for field operation
- operational checks and field maintenance of AUT systems
- documentation/verification of in field modifications of AUT systems
- return of field systems, dismantling, check/repair/upgrading of system components
- verification of repaired/upgraded system components against given requirements
- AUT operator training and qualification.

Project specific set-up files, to be included in project specific procedures:

- Phased array focal laws (if applicable)
- Probe stand off
- Sound angles
- Target depth
- Required over trace
- Applied thresholds.

111 If an embedded defect is located close to a surface, such that the ligament height is less than half the defect height, the ligament height between the defect and the surface shall be included in the defect height.

B 200 Documentation

201 The configuration of the ultrasonic system shall for evaluation purposes be described and documented with regard to:

- brief functional description of the system
- reference to the code, standard or guideline used for design and operation of the system
- description of the Quality Assurance system
- equipment description
- limitations of the system with regard to material or weld features including sound velocity variations, geometry, wall thickness, size, surface finish, material composition, etc.
- number and type of transducers, or phased array set up with description of characteristics and set-up
- number of and height of examination zones, where relevant
- gate settings
- function of scanning device
- ultrasonic instrument, number of channels and data acquisition system
- recording and processing of data
- calibration blocks

- coupling monitoring method
- temperature range for testing and limitations
- coverage achieved
- maximum scanning speed, PRF and direction
- reporting of indications and documentation of calibration and sensitivity settings.

B 300 Scope of qualification

301 Automated ultrasonic systems used for linepipe girth weld inspection shall be qualified and the performance of the system shall be documented.

The qualification shall be according to DNV-RP-F118, further guidance is given in Subsection H.

For applications other than ferritic steel girth weld examinations, specific requirements can apply and should be agreed upon.

Once an AUT system is qualified, only a limited AUT Validation will be required for future projects if the system is within the qualified range of validity, as specified in section I. The scope of AUT validation shall be according to DNV-RP-F118, section 9. A reduced scope of validation may be agreed for welds exposed to nominal strains < 0.4%, but shall comprise at least 12 defects, including 2 observations for each group (root, fill, cap and volumetric) and/or critical flaw type.

B 400 Ultrasonic system equipment and components

General requirements

401 The system shall be capable of examining a complete weld including the heat affected zone in one circumferential scan. This requirement may, as agreed, be deviated from for very thick / small diameter pipe, if it is not possible to cover the whole depth range in one scan.

402 There shall be recordable signal outputs for at least each 1 mm of weld length for each inspection channel.

403 The ultrasonic instrument shall provide a linear A-scan presentation. The instrument linearity shall be determined according to the procedures detailed in ASTM-317-01 or EN12668. Instrument linearity shall not deviate by more than 5% from ideal.

The assessment of ultrasonic instrument linearity shall have been performed within 6 months of the intended end use date. For production AUT with an expected duration exceeding 6 months, but less than one year, the assessment of instrument linearity may be performed immediately before the start of work.

A calibration certificate shall be made available upon request.

Specific requirements for ultrasonic instruments using multiple channels, pulse echo, tandem and/or through transmission techniques.

404 The instrument shall provide an adequate number of inspection channels to ensure the examination of the complete weld through thickness in one circumferential scan, if possible (see B401). Each inspection channel shall provide:

- pulse echo or through transmission modes
- one or more gates, each adjustable for start position and length
- gain adjustment
- recording threshold between 5 and 100% of full screen height
- recording of either the first or the largest signal in the gated region
- signal delay to enable correlation to distance marker positions (real time analogue recording only)
- recordable signal outputs representing signal amplitude and sound travel distance
- specific requirements to ultrasonic instruments using the ToFD technique

405 The instrument shall provide a ToFD B-scan image. ToFD function software shall incorporate adequate facilities for online indication assessment using range calibrated cursors. A-scan reference and numerical translation of time of flight positions shall be incorporated.

Depth range efficiency shall be identified for each ToFD set up. It may be required to employ two or more ToFD channels in order to increase reliability over the through thickness range being inspected. For thicknesses above 50 mm at least two TOFD channels are recommended.

406 The instrument shall fulfil the requirements to ultrasonic instruments described in EN12668-1 and EN583-6, Chapter 6 “Equipment requirements”

Specific requirements to ultrasonic instruments using phased arrays.

407 The phased array system shall incorporate means for periodical verification of the function of required active elements necessary to maintain a specific focal law.

408 A system preventing any unqualified alterations to agreed focal laws shall be implemented for the phased array AUT system.

409 If additional conventional transducers to the phased array ones are used, for example for transverse

inspection and ToFD, the information for all transducers shall be available in the same set up and recording system.

The recording system

410 The recording or marking system shall clearly indicate the location of imperfections relative to the 12 o'clock position of the weld, with a $\pm 1\%$ accuracy or 10 mm, whichever is greater. The system resolution shall be such that each segment of recorded data from an individual inspection channel does not represent more than 2 mm of circumferential weld distance.

Acoustic coupling

411 Acoustic coupling shall be achieved by contact or couplant column using a liquid medium suitable for the purpose. An environmentally safe agent may be required to promote wetting, however, no residue shall remain on the pipe surface after the liquid has evaporated.

The method used for acoustic coupling monitoring and the loss in signal strength defining a “loss of return signal” (loss of coupling) shall be described.

Transducers

412 Prior to the start of field weld examination, details of the types and numbers of transducers or focal laws shall be specified. Once agreed, there shall not be any transducer or focal law design changes made without prior agreement. Transducers other than phased arrays shall be characterised according to EN12668-2. Transducers shall be documented with respect to manufacturer, type, characteristics and unique identification (serial number).

Transducer characteristics shall include (not all parameters are applicable to phased array transducers):

- frequency
- beam angle
- wedge characteristics
- beam size (Not relevant for PA probes)
- pulse shape
- pulse length
- signal to noise
- focus point and length for focused transducers.

In addition, the following characteristics shall be included for phased array probes:

- Number of elements
- pitch.

413 Transducers used for zonal discrimination shall give signals from adjacent zones (overtrace), given that there is no shift in weld bevel angle between the zones. For adjacent zones of comparable size and with equal calibration sensitivity, the overtrace shall be within 5% FSH to 40% FSH when the peak signal from the calibration reflector representing the zone of interest is set to 80% FSH.

414 TOFD transducers shall be optimised for the wall thickness to be tested and the refracted angle shall be the same for transmitter and receiver. Frequency, damping and incident angle shall be chosen to limit the dead zone formed by the lateral wave.

415 When required, transducers shall be contoured to match the curvature of the pipe.

B 500 Calibration (reference) blocks

501 Calibration blocks shall be used to set AUT system sensitivity, and to verify the inspection system for field inspection and to monitor the ongoing system performance. Calibration blocks shall be manufactured from a section of pipeline specific linepipe. The wall thickness of the pipe used for calibration blocks shall preferably correspond to the nominal wall thickness of the pipes used, unless a number of calibration blocks are needed to cover wall thickness variations outside the limitations given in B107.

502 When a weld is required in the calibration block, the weld shall be 100% examined to ensure that it is completely defect free. The weld shall be made from representative production material using project specific approved welding procedure.

503 Acoustic velocity and attenuation measurements shall be performed on material from all sources of pipe material supply to be used. These measurements shall be performed according to Subsection J100 unless an equivalent method is agreed. If differences in acoustic velocity for the same nominal wall thickness from any source of supply results in a beam angle variation of more than 1.5° , specific calibration blocks shall be made for material from each source of supply showing such variations.

504 Details of the specific weld bevel geometries including relevant dimensions and tolerances shall be provided in order to determine the particulars and numbers of calibration blocks required.

505 Type and size of calibration reflectors shall be determined by the required sensitivity to achieve the necessary Probability of Detection (PoD) and sizing capability as determined by the smallest allowable defect

deriving from the agreed acceptance criteria. The preferred principal calibration reflectors are flat bottom holes (FBHs) and surface notches. Other reflector dimensions and types may be used, if it is demonstrated during the system qualification that the defect detection and sizing capabilities of the system is acceptable. Specific notches for ToFD may be incorporated, to check TOFD system functionality.

506 The calibration blocks shall be designed with sufficient surface area so that the complete transducer array will traverse the target areas in a single pass.

507 Drawings showing the design details for each type of calibration block shall be prepared. The drawings shall show:

- the specific weld bevel geometry, dimensions and tolerances
- the height and position of examination zones
- the calibration reflectors required and their relative positions
- sketch of the intended ultrasonic path associated with each reflector.

508 The calibration block shall be identified with a hard stamped unique serial number providing traceability to the examination work and the material source of supply for which the standard was manufactured. Records of the correlation between serial number and wall thickness, bevel design, diameter, and ultrasound velocity shall be kept and be available.

The machining tolerances for calibration reflectors are:

- | | |
|--|---------------|
| (a) Hole diameters | ± 0.2 mm |
| (b) Flatness of FBH | ± 0.1 mm |
| (c) All pertinent angles | $\pm 1^\circ$ |
| (d) Notch depth | ± 0.1 mm |
| (e) Notch length | ± 0.5 mm |
| (f) Central position of reference reflectors | ± 0.1 mm |
| (g) Hole depth | ± 0.2 mm |

509 The lateral position of all calibration reflectors shall be such that there will be no interference from adjacent reflectors, or from the edges of the blocks.

510 Holes shall be protected from degradation by covering the hole with a suitable sealant. If it can be proven that filling of surface notches and other near surface reflectors may influence the reflecting ability of the reference reflector, avoidance of filling can be subject to agreement.

511 Dimensional verification of all calibration reflectors and their position shall be performed and recorded according to a documented procedure. Each reflector shall be verified by ultrasonic testing to ensure that the reference reflector pairs yield reflective signals within ± 2 dB.

512 Whenever possible, an AUT system similar to that used during field inspection shall be successfully calibrated against the calibration block after dimensional verification of the block. The set-up data shall be recorded and the same data used to verify that any additional/spare calibration blocks will not give significantly different calibration results.

513 A calibration block register shall be established. The register shall include all calibration blocks, including spare blocks, to be used, identified with a unique serial number and include the drawings, dimensional verification records, ultrasound velocity, name of the plate/pipe manufacturer and the heat number.

B 600 Recorder set-up

601 Channel output signals shall be arranged on the recording media in an agreed order. The function of each channel shall be clearly identified. The hard copy recording shall be corrected to account for any difference introduced due to different circumferential positions of the transducers.

602 Distance markers shall be provided on the recording at intervals not exceeding 100 mm of circumferential weld length.

603 The scanning direction (clockwise or anti-clockwise) shall be clearly described and referred to an identifiable datum, and shall be maintained throughout the duration of the field weld examination.

B 700 Circumferential scanning velocity

701 The maximum allowable circumferential scanning velocity shall be determined so that there are at least 3 pulse firings within each 6 dB beam width at the appropriate operating distance of all transducers within the an array, as described in Appendix D, H412.

B 800 Power supply

801 Constant power supply shall be ensured for the ultrasonic system. There shall be provisions for

alternative power supply in case of failure in the main power supply. There shall be no loss of inspection data as a result of a possible power failure.

B 900 Software

901 All recording, data handling and presenting software, including changes thereto, shall be covered by the Quality Assurance system and all software versions shall be identifiable by a unique version number.

902 The software version number, and for phased array equipment also each identified set-up (executable focal law programme) in use, shall be clearly observable on all display and printout presentations of calibration and examination results.

903 For phased array equipment, each identified set-up (executable focal law programme) shall be available for review.

904 Software updates shall not be performed on systems during field examination use.

B 1000 Reference line, band position and coating cut-back

Reference line

1001 Prior to welding a reference line shall be scribed on the pipe surface at a fixed distance from the centreline of the weld preparation on the inspection band side. This reference line shall be used to ensure that the band is adjusted to the same distance from the weld centreline as to that of the calibration block.

Guiding band positioning

1002 The tolerance for band positioning is ± 1 mm relative to the weld centreline.

The band can be positioned either wholly on the bare pipe or on the corrosion coating.

Positioning of the band on the corrosion coating will require that the coating thickness is not excessive and that the coating is sufficiently flat and will remain hard enough at the temperatures in the pipe resulting from preheat and welding to avoid that the band supports slips or penetrates the coating.

Positioning of the band partly on bare pipe and partly on the corrosion coating may result in instability problems for the scanner and should be avoided.

Coating cut back

1003 The cut-back of the corrosion coating to bare pipe shall be wide enough to accommodate the footprint of all transducers at the required stand-off distance + minimum 20 mm. The cut-back of any weight coating shall allow placing the band wholly on the bare pipe or on the corrosion coating, as applicable, and sufficient to avoid interference between weight coating and scanner.

The coating cut back required allowing for scanner mounting and movement shall be clearly identified in the operating manuals.

B 1100 Reference line tools

1101 The tool used to align the scanning band to the reference line shall be adjusted to account for weld shrinkage. Shrinkage is determined by marking the reference line on both pipe ends during WPQ or for the first 25 welds, and then measuring the distance between them after welding.

The tools used for marking the reference line for band positioning, shall give accuracy in the position of the scribe line of ± 0.5 mm relative to the bevel root face. The accuracy of each scribe line tool shall be documented and each tool shall be uniquely identified.

B 1200 Operators

1201 Details of each AUT operator shall be provided prior to start of field weld examination.

1202 Operators performing interpretation shall be certified to Level 2 by a Certification body or Authorised qualifying body in accordance with EN 473, ISO 9712 or the ASNT Central Certification Program (ACCP). In addition they shall document adequate training and field experience with the equipment in question, by passing a specific and practical examination. If requested, they shall be able to demonstrate their capabilities with regard to calibrating the equipment, performing an operational test under field conditions and evaluating size, nature and location of imperfections.

1203 Operators who are not accepted shall not be used, and operators shall not be substituted without prior approval. In case additional operators are required, details of these shall be accepted before they start to work.

1204 One individual shall be designated to be responsible for the conduct of the ultrasonic personnel, the performance of equipment, spare part availability and inspection work, including reports and records.

1205 The operators shall have access to technical support from one individual qualified to Level 3 at any time during execution of the examination work.

B 1300 Spares

1301 There shall be a sufficient number of spare parts available at the place of examination to ensure that the

work can proceed without interruptions.

B 1400 Slave monitors

1401 The system shall include the possibility to provide slave monitors for use by supervising personnel, if agreed.

C. Procedure

C 100 General

101 A detailed AUT Procedure shall be prepared for each weld joint geometry to be examined prior to the start of any welding. The procedure is as a minimum, and as relevant for the equipment in question, to include:

- functional description of equipment
- reference standards and guidelines controlling equipment maintenance
- instructions for scanning device, ultrasonic instrument, ultrasonic electronics, hard- and software for recording, processing, display, presentation and storage of inspection data
- number of examination zones for each wall thickness to be examined, as relevant
- transducer configuration(s), characteristics, types, coverage; and/or focal law details
- description/drawings of calibration block(s), including type, size and location of all calibration reflectors
- pre-examination checks of equipment
- methodology for sensitivity setting and for fusion zone transducers; overtrace (signal amplitude from adjacent zones) requirements consistent with the overtrace used as basis for establishing height sizing corrections for amplitude sizing
- gate settings
- equipment settings
- threshold settings
- the added gain above PRL (D102) to be used for mapping channels
- dynamic verification of set-up
- signal strength defining a “loss of return signal” (loss of coupling)
- visual examination of scanning area, including surface condition and preparation
- identification of inspection starting point, scanning direction, and indication of length inspected
- method for scanner alignment and maintenance of alignment
- verification of reference line and guide band positioning
- maximum allowed temperature range
- control of temperature differentials (pipe and calibration block)
- calibration intervals
- calibration records
- couplant, coupling and coupling control
- operational checks and field maintenance
- transducer and overall functional checks
- height, depth and length sizing methodology
- acceptance criteria, or reference thereto
- instructions for reporting including example of recorder chart and forms to be used
- spare part philosophy.

102 The AUT procedure shall be submitted for acceptance.

D. Calibration (Sensitivity Setting)

D 100 Initial static calibration

Transducer positioning and Primary Reference Sensitivity

101 The system shall be optimised for field inspection in accordance with the details given in the AUT procedure and using the relevant calibration block(s). The calibration block shall have the same orientation (vertical/horizontal) as the pipe to be tested, unless it has been proven through the qualification tests that differences in response are negligible.

102 The gain level required to produce the peak signal response is the Primary Reference Level (PRL) for that reflector.

Fusion zone channels

103 Pulse echo and tandem transducers shall be positioned at its operating (stand-off) position and adjusted to provide a peak signal from its calibration reflector. In the case of phased arrays, the focal laws shall be designed to provide a peak signal from each of the calibration reflectors as appropriate. This signal shall be adjusted to the specified percentage of full screen height (FSH).

TOFD channels

104 For single TOFD channels, the transducer spacing shall be selected to place the theoretical crossing of beam centres at the weld centreline at 66 to 95% of the wall thickness.

For double TOFD channels the theoretical crossing of beam centres at the weld centreline shall be at 66 to 95% of the wall thickness for one channel and approximately 33% of the wall thickness for the other channel.

The amplitude of the lateral wave shall be between 40 and 80% of full screen height (FSH). In cases when use of the lateral wave is not applicable, e.g. surface conditions and steep beam angles, the amplitude of the back wall signal shall be set at between 12 to 24 dB above FSH. When use of neither the lateral wave nor the back wall signal is applicable, the sensitivity should be set such that the noise level is between 5 and 10% of FSH.

Mapping channels

105 Each transducer shall be positioned at its operating (stand-off) position and adjusted to provide a peak signal from its calibration reflector. In the case of phased arrays, the focal laws shall be designed to provide a peak signal from each of the calibration reflectors as appropriate. This signal shall be adjusted to the specified percentage of FSH.

Normally a gain increase in the range of 4 to 10 dB over the gain necessary to obtain the specified percentage of FSH is required to obtain the production scanning sensitivity. This gain shall not be added during sensitivity setting, dynamic calibration and calibration verification during field examination.

D 200 Gate settings

201 With each transducer positioned for a peak signal response from the calibration reflector the detection gates shall be set as detailed in the agreed AUT procedure and as detailed below.

Fusion zone channels

202 The detection gates are to be set with each transducer / focal law positioned for the peak signal response from the calibration reflector. The gate shall start before the theoretical weld preparation and a suitable allowance shall be included to allow for the width of the heat affected zone, so that complete coverage of the heat affected zone is achieved. The gate ends shall at least be after the theoretical weld centreline, including a suitable allowance for offset of the weld centreline after welding.

203 For specific applications, e.g. for austenitic/duplex weldments with angle compression waves with the reference reflectors positioned at the far side of the weld, an extension of the gate onto the far bevel and HAZ may be required.

Similar considerations may apply in the root area related to monitoring of guidance band offset.

ToFD technique

204 Ideally the time gate start should be at least 1 μ s prior to the time of arrival of the lateral wave, and should at least extend up to the first back wall echo. Because mode converted echoes can be of use in identifying defects, it is recommended that the time gate also includes the time of arrival of the first mode converted back wall echo.

205 As a minimum requirement, the time gate shall at least cover the depth region of interest.

206 Where a smaller time gate is appropriate, it will be necessary to demonstrate that the defect detection capabilities are not impaired.

Mapping channels

207 The mapping channels shall encompass the HAZ and the total weld volume dedicated to the transducer or focal law.

D 300 Recording threshold

Threshold level

301 It shall be verified that the threshold level, based on data from the AUT system qualification, is set low enough to detect the minimum height critical defect identified in the acceptance criteria (see Subsection H300).

302 The threshold levels shall in any case not be set higher than required in the following.

Fusion zone channels

303 The recording threshold for fusion zone channels shall be at least 6 dB more sensitive than the reference reflector, unless a different sensitivity is required for detection of indications depending upon the size of reflectors used and the applicable acceptance criteria.

304 TOFD technique The recording threshold for ToFD is not recommended to be changed from the calibration threshold. However, a change of threshold may be prescribed in the procedure.

Mapping channels

305 The recording threshold for mapping channels shall be at least 14 dB more sensitive than the reference reflector signal.

D 400 Dynamic calibration

Detection channels

401 With the system optimised, the calibration block shall be scanned. The position accuracy of the recorded reflectors relative to each other shall be within ± 2 mm, and with respect to the zero start within ± 10 mm.

402 For all phased array focal laws or transducers the recording media shall indicate the required percentage of FSH and locate signals from each calibration reflector in its correctly assigned position. The overtrace shall be in accordance with the requirements given in the AUT procedure.

Coupling monitor channels

403 The coupling monitor channels shall indicate no loss of return signal as required by the procedure.

D 500 Recording of set-up data

501 Sufficient data shall be recorded on a “set-up sheet” to enable a duplication of the original set-up at any stage during field inspection.

As a minimum the PRL, the signal to noise (S/N) ratio, the stand-off distance for each transducer, and settings for gate start and gate length for each channel shall be recorded.

502 The calibration qualification chart shall be used as the inspection quality standard to which subsequently produced calibration charts may be judged for acceptability. This recording shall be kept with the system Log Book. For phased array equipment also the identified set-up (executable focal law programme) used shall be recorded.

503 In addition to the qualification chart required above, any changes in the data records made in accordance with D501 above shall be recorded.

The “set-up sheet” shall after dynamic calibration include as a minimum:

- PRL and the signal to noise (S/N) ratio for each transducer
- the stand-off distance for each transducer and alignment of tandem transducers
- the settings for gate start and gate length for each channel
- the gain to be added to any channel during field examination
- filtering settings, when applicable
- the order of transmitters and receivers
- calibration block identification.

E. Field Inspection

E 100 Inspection requirements

General requirements

101 The ultrasonic system used for examination during production shall in all essential aspects be in compliance with the set-up and configuration of the system used for system qualification (see Subsection H).

Documentation

102 The following documentation shall be available at the place of field examination:

An AUT system dossier for each operating AUT system including performance/characteristics data and identification of at least:

- pulser/receiver
- transducers
- umbilical
- encoder
- software version and executable focal law programmes (when applicable)
- other essential equipment.

An AUT system spare parts dossier including:

- performance/characteristics data and identification of essential spare parts.

A calibration block register including:

- the documentation for each calibration block, including spares, as required by B513.

An AUT personnel qualification dossier including:

- certificates for all AUT personnel.

An AUT procedures dossier including:

- AUT procedures to be applied
- AUT system check and maintenance instructions
- work instructions for AUT personnel.

Additional information including:

- other NDT procedures
- AUT and NDT acceptance criteria.

103 The AUT system dossier shall be updated when changes of parts/components are made and shall at all times reflect the current configuration of the AUT system in use.

The AUT system spare parts dossier shall be updated whenever parts/components are replaced or new parts/components arrive and shall at all times reflect the number of spares available.

System Log Book

104 The System Log Book shall be kept at the place of inspection, and be made available for review upon request.

The system log book shall be continuously updated and at least include the following information:

- set-up data as required in D500
- the calibration qualification chart(s)
- replacement of main components with spares from stock
- replacement of calibration block
- results from operational checks
- results of periodical verifications (linearity checks, calibration block wear, element verification for phased array transducers etc.)

105 Hard copy recordings for each calibration scan (and phased array set up file, if appropriate) shall be included sequentially with the weld inspection charts. The last weld number examined before calibration and the time at which the calibration was performed shall appear on each calibration chart.

Pre-examination tests

106 Before the ultrasonic system is used for field examination of production welds the system shall be tested. After calibration of the complete system using the applicable “set-up sheet” parameters, the calibration block shall be scanned. If any of the echo amplitudes from the reflectors of the calibration block deviate more than 2 dB from the initial calibration, corrections shall be made.

The system shall not be used until 5 successive satisfactory scans are obtained.

The total noise level from transducer, material including weld, electronics and any other sources shall not exceed the single output representing the smallest allowable critical flaw.

At least one scan shall be performed with the scanning surface wiped dry. The coupling monitor channels shall indicate loss of return signal as required by the procedure.

In addition, a power failure shall be simulated and operation of the system on the alternative power source with no loss or corruption of examination data shall be verified.

Verification of Calibration

107 The calibration of the system shall be verified by scanning the calibration block before and after inspection of each weld. The gain added to any channel for field examination shall be removed during verification scans.

108 If agreed, the frequency of calibration scans may be reduced to a minimum of 1 scan for each 10 consecutive welds. If a calibration fails, the preceding welds counting back to last acceptable calibration shall be re-inspected.

109 The verification scans shall not show amplitude changes in any channel outside ± 2 dB from the reference calibration chart (see D501).

110 The peak signal responses from each verification scan shall be recorded. Any gain changes required to maintain the PRL in the set-up sheet (see D502) shall be recorded.

Re-calibration

111 The system shall be re-calibrated and a new reference calibration chart shall be established according to Subsection D if a verification scans shows amplitude changes in any channel outside ± 2 dB from the reference calibration chart or if gain changes outside ± 2 dB are required to maintain the PRL in the set-up sheet.

112 The system shall also be re-calibrated and a new reference calibration chart and a new set-up sheet established:

- at any change of calibration block
- at any change of nominal wall thickness
- at any change of components, transducers, wedges or after resurfacing of transducers
- before and after examination of repairs, if system is outside initial tolerances
- after any adjustments to scanner head or transducers
- after any change in the order of transmitters and receivers and filtering settings.

Weld identification

113 Each weld shall be numbered in the sequence used in the pipe tracking system.

114 The starting point for each scan shall be clearly marked on the pipe and the scan direction shall be clearly marked using an arrow. If the scanning direction is changed from the regular direction, this shall be noted on the records of the scan.

E 200 Operational checks

201 Operational checks shall be performed according to a documented procedure. The execution of and the results of the operational checks shall be recorded in the system log book.

202 The following operational checks shall be performed for every weld inspected:

- reference line shall be within required tolerance and clearly marked around the pipe circumference
- the scanning surface shall be free of weld spatter and other that may interfere with the movement of transducers
- physical damage and loose connections in the band. band position shall be within a tolerance of maximum ± 1.0 mm
- the pipe surface temperature and the difference between calibration block temperature and pipe temperature shall be within the required tolerance.

203 The following operational checks shall be performed daily or at least once per shift:

- the scanner head shall be checked for physical damage and loose connections
- the bevel prepared at the bevelling station shall be of the specific weld bevel geometry, dimensions and tolerances shown on the drawings of the calibration block in use
- the calibration block in use shall be checked for physical damage and scanning tracks
- transducers shall not be rocking in the scanner and shall be in firm contact with the scanning surface. the transducers shall be firmly screwed onto the wedges. the transducer wear faces (wedges) shall be checked for scores which may cause local loss of contact
- the transducer stand-off distance shall be as recorded in the set-up sheet within ± 0.5 mm
- the position accuracy of the chart distance markers shall be shall be ± 1 cm or better.

204 Other operational checks such as linearity checks and transducer element verification checks (when applicable) and field maintenance shall be performed according to the AUT system check and maintenance instructions.

Guidance note:

Checking of transducer angles may require a custom made block since the standard V1 block may not be wide enough to include the carbide tips during checks and due to that the gap between the V1 block and transducers with radiused surfaces will be too large for adequate checks.

---e-n-d---of---G-u-i-d-a-n-c-e---n-o-t-e---

205 A verification scan shall be performed prior to resuming inspection after the operational checks required in E203 and any field maintenance. The verification scan shall meet the requirements given in E109.

If necessary, a re-calibration shall be performed and a new reference calibration chart shall be established according to Subsection D.

E 300 Adjustments of the AUT system

301 Adjustments to the AUT system other than correcting deviations from the qualified set-up sheet following operational checks and maintenance shall not be performed. Fine adjustments to the sensitivity settings by changing the gain settings to optimise the peak signal response to accommodate mechanical wear can be made within a window of ± 1.0 dB.

302 Practices such as changing transducer angles by lifting transducer front and back by adjusting of carbides, changing stand-off distances and changing the order of transmitter/receivers etc. are not permitted.

E 400 Acceptance criteria

401 Acceptance criteria applicable for automated ultrasonic testing (AUT) of pipeline girth welds exposed to total nominal strains <0.4% are given in Table E-1. It is not applicable to C-Mn pipes and low alloy steel subjected to sour service conditions. The AUT system shall be qualified according to this appendix. The acceptance criteria of Table E-1 assumes a height sizing accuracy within ±1 mm, as evaluated according to clause H302. The acceptance criteria of Table E-1 are therefore only valid as long as the height sizing accuracy is documented to be within ±1 mm upon the qualification. The inspection threshold is recommended set at 40% FSH for pulse echo zones. In addition, clause H301 shall be satisfied for maximum acceptable defect heights specified in Table E-1.

402 For AUT system used for inspection of girth welds in pipelines of duplex stainless steel, CRA and clad/ lined materials, a probability of rejection of 85% at a 95% confidence level or higher shall be documented through the qualification for defects in the root of heights smaller than 1.0 mm, considering the applied AUT rejection criteria for root defects.

Table E-1 Acceptance criteria for automated ultrasonic testing of girth welds		
<i>Base material</i>	<i>Defect location</i>	<i>Acceptance criteria</i> ^{1) 2) 3) 4)}
	Individual defect indications	Maximum accumulated length of defect indications in any 300 mm weld length
C-Mn and low alloy steels ^{6,8)}	Root	Height: the lesser of weld pass height and 0.2 t, but max. 3 mm; Length: t, but max. 25 mm ⁵⁾
	Surface	
	Embedded ⁷⁾	Height: the lesser of weld pass height and 0.2 t, but max. 3 mm; Length: 2t, but max. 50 mm
Duplex stainless steel, CRAs and clad/ lined steel	Root ⁹⁾ Up to 3 mm from inside surface, and up to 1.5 mm above clad/liner thickness for clad/ lined steel	Height: max. 1 mm, the lesser of a third of clad/ liner thickness and 1 mm for clad/ lined steel; Length: t, but max. 25 mm
	Surface	Height: the lesser of weld pass height and 0.2 t, but max. 3 mm; Length: t, but max. 25 mm
	Embedded ⁷⁾ At least 3 mm from inside surface, and at least 1.5 mm above clad/liner thickness for clad/ lined steel	Height: the lesser of weld pass height and 0.2 t, but max. 3 mm; Length: 2t, but max. 50 mm
Cracks are not permitted.		
Porosity: For single layer welds: 1.5% of projected area, for multi layer welds with t < 15 mm 2% of projected area, for multi layer welds with t ≥ 15 mm 3% of projected area. Maximum 10% porosity in cluster area. “Isolated” pores are separated by more than 5 times the diameter of the largest pore.		
Notes:		
1) Volumetric defects separated by less than the length of the smallest defect or defect group shall be considered as one imperfection.		
2) Planar defects interaction shall be assessed according to the criteria of BS 7910. Interacting planar defects shall be attributed equivalent defect dimensions according to BS 7910, and the equivalent defects so obtained shall meet the above acceptance criteria.		
3) Detectable imperfections are not permitted in any intersection of welds.		
4) Systematic imperfections that are distributed at regular distances over the length of the weld are not permitted even if the size of any single imperfection meets the requirements above.		
5) Acceptance criteria of Table D-4 shall also be satisfied.		
6) This table is not applicable for C-Mn and low alloy steels in sour service.		
7) If an embedded defect is located close to a surface, such that the ligament height is less than half the defect height, the ligament height between the defect and the surface shall be included in the defect height, and the defect shall be considered as a root or surface defect, as applicable.		
8) POD and sizing accuracy of the AUT system shall be according to Appendix E, clause E401.		
9) The Probability of Rejection (PoR) for a 1 mm high flaw shall be qualified to be higher or equal to 85% at 95% confidence level.		

F. Re-examination of Welds

F 100 General

101 Welds shall be re-examined whenever any of the following occur:

Sensitivity

102 Welds examined at a sensitivity outside ± 2 dB from the PRL shall be re-examined.

Coupling loss

103 Welds exhibiting a loss of acoustic coupling over a circumferential distance which exceeds the minimum allowable defect length for the affected channel shall be re-examined. Coupling loss in two adjacent zones at the same position requires re-examination. In cases where the minimum allowable defect height according to applicable acceptance criteria is smaller than the zone height for the affected channel, the weld shall be re-examined.

Out of calibration

104 If a verification scan shows that the system is in any way “out of calibration”, all welds examined since the last successful verification scan shall be re-examined.

G. Evaluation and Reporting

G 100 Evaluation of indications

101 Indications from weld imperfections shall be evaluated against the defect acceptance criteria.

102 Indications shall be evaluated following the height, depth and length sizing methodology given in the AUT procedure. All information available shall be used in the evaluation to avoid undersizing, - and excessive oversizing of indications.

103 Indications recorded from sources other than weld imperfections shall be evaluated. Their nature shall be clearly identified in the examination report.

104 All evaluations shall be completed immediately after examination of the weld.

G 200 Examination reports

201 The examination results shall be recorded on a standard ultrasonic report form. The reports shall be made available on a daily basis or on demand.

202 The following items are as a minimum to be reported for each indication found to be not acceptable:

- project reference
- pipeline identification
- weld identification/number
- date
- ultrasonic procedure number with associated revision
- circumferential position of indication
- height, depth and length of indication
- transverse location of defects/indications (US, DS, Central)
- maximum amplitude for each reported indication
- indication type.

G 300 Inspection records

301 The following inspection records shall be provided:

- a hard copy record of each weld examined
- an assessment of the weld quality according to the acceptance criteria
- hard copy records of all calibration scans
- examination data in electronic form.

302 In lieu of hard copy records an alternative recording media is acceptable. Where weld interpretation has been performed using digitally processed signals, the data files shall be stored and backed up immediately following

the examination of each weld. The stored data shall be in the same format as used by the operator to assess the acceptability of welds at the time of examination.

303 If agreed, a software package and one set of compatible hardware shall be provided in order to allow the weld data file to be retrieved in the same manner as the operator viewed the data at the time of inspection.

H. Qualification

H 100 General

101 The AUT system shall be qualified according to DNV-RP-F118 for the applications it is intended used for. The qualification shall be based on the required performance as identified by the requirements for Probability of Detection (PoD) and sizing ability; or, alternatively a requirement to defect rejection.

102 The qualification is AUT system specific and shall only be valid when all essential variables remain nominally the same as covered by the documented qualification. This standard does not require a new qualification to be performed provided that the documented performance i.e. PoD and sizing ability meets or exceeds the requirements for the specific application being considered.

103 Qualification involves a technical evaluation of the AUT system and application in question combined with any required practical tests.

104 The qualification shall be based on a detailed and agreed qualification programme, that covers the following:

- Qualification objective, i.e. materials, weld process, groove geometries and performance requirement (PoD and Sizing accuracy).
- Details of trials to establish and document environmental and application related tolerances such as temperature consistency, beam and focal law consistency, mechanical stability and electronic interference sensitivity.
- Details of reliability trials and trial welds.

105 The agreed qualification programme and its implementation shall be supervised and endorsed by a recognised and competent independent 3rd party.

H 200 Scope

201 A qualification programme shall document the following:

- fulfilment of the requirements to AUT systems according to this Appendix
- the repeatability of the AUT system under variable examination conditions
- the sensitivity of the AUT system to the temperature of tested objects
- the ability of the AUT system to detect defects of relevant types and sizes in relevant locations
- the accuracy in sizing and locating defects.

H 300 Requirements

Detection

301 The detection ability of an AUT system shall be deemed sufficient if the probability of detecting a defect of the smallest allowable height determined by an Engineering Critical Assessment (ECA) or by other considerations is 90% shown at a 95% confidence level (i.e. a 90%|95% PoD).

Sizing accuracy

302 Sizing accuracy shall be established during the qualification programme. For this purpose it is required to demonstrate the accuracy over the range of expected defect sizes. Based on the determined sizing errors, the under sizing error tolerances giving less than or equal to 5% probability of under sizing shall be determined and used in relation to any ECA specified defect sizes.

No specific tolerance is required for over sizing of indications. Over sizing of indications should however be within reasonable limits since excessive oversizing will result in unnecessary repairs during pipeline construction. A systematic over sizing, i.e. over sizing on average, of 0.8 mm or above shall lead to investigations and corrective actions to reduce the over sizing in the affected parts of the AUT set-up.

Rejection

303 The detection criterion of H301 and the undersizing tolerance specified in H302 may be combined into one rejection criterion: There shall be more than 85% probability of rejecting a defect, which is not acceptable according to determined ECA criteria. This shall be shown at a 95% confidence level, i.e. a Probability of Rejection (PoR) of 85%|95% is required. This rejection criterion approach may be preferable when the two step process detection-sizing is not followed, e.g. when acceptance or rejection is based directly on echo amplitudes, or solely on AUT reported defect sizes.

304 The AUT system shall be deemed unqualified for its purpose with respect to ECA determined non-acceptable defects if it is not possible to document adequate detection and sizing abilities according to H301 and H302, or adequate rejection abilities according to H303.

H 400 Variables

401 Variables, which must be taken into account during a qualification, include, but are not necessarily limited to:

- welding method and groove geometry
- welding consumables
- base material (Distinction is made on materials with substantially differences in ultrasonic response, for instance between CMn, 13% Cr, duplex or austenitic steels).
- wall thickness limitations
- pipe diameter limitations
- temperature consistency
- root and cap channels transducer set-up
- transducer set-up for other channels (the number of these channels may be increased or decreased provided there are no set-up changes)
- focal law design procedure (Phased array probes only)
- reference reflectors
- system, data acquisition and data treatment
- software version (except changes affecting viewing or display only).
- AUT operator/interpreter training and qualification.

H 500 Qualification programme

General

501 A full qualification programme for a specific application of an AUT system will in general comprise the following stages:

- 1) Review of the technical documentation of the AUT system
- 2) Review of the operating methodology for the AUT system
- 3) Review of the quality assurance system for development, verification, maintenance and operation of the AUT system.
- 4) Review of available performance data for the AUT system.
- 5) Evaluation and conclusions based on the information made available.
- 6) Identification and evaluation of significant parameters and their variability.
- 7) Planning and execution of a repeatability test programme, see H705 and H706.
- 8) Planning and execution of a temperature sensitivity test programme, see H707 and H708.
- 9) Planning and execution of a reliability test programme, see H709 and H710.
- 10) Documentation of results from the repeatability and reliability test programmes.
- 11) Reference investigations by supplementary NDT and destructive testing.
- 12) Evaluation of results from repeatability, temperature sensitivity and detection ability and sizing accuracy trials.

502 The extent of the qualification programme will reflect the range for which the AUT system is intended to be used, as described in the general AUT procedure.

503 Practical tests of the AUT system is a requirement. Information pertaining to these practical tests is given in H700.

For a full qualification historical qualification data, in compliance to the requirements of sections H600 and H700, can be utilised if these data can be clearly identified and supported with all relevant documentation. However the minimum amount of new data shall at least represent 50% of the total minimum required qualification observations according to H604. It shall be noted that once undergone a full qualification, the results are valid as historical data for use according to this standard on similar configuration, with reference to I101. Validity for specific configurations can be documented through validation scopes including a limited number of defective welds and defects if deemed relevant.

H 600 Test welds

601 Qualification testing shall be performed using test welds containing intentionally induced defects typical of those expected to be present in welds produced with the welding methods to be used. The preferred method for seeding intentional flaws are by varying welding process parameters to induce natural flaws. However, EDM notch technique may substitute 70% of the total number of flaws in each flaw group. Ref tables E-2, E-3 and E-4. Hence a minimum of 30% natural flaws shall be part of the data population.

602 The material and the weld geometry shall be as for the actual use of the equipment. Minor variations to for instance the weld root groove, which are regarded irrelevant in relation to the AUT system, may be acceptable.

If repair welds are to be covered by the qualification, a representative selection of these should also be included.

603 The intentionally introduced defects shall vary in length, height and location. Too close spacing and stacking of the defects shall be avoided. If a POD analysis shall be performed, it is required also to include

sizes, which are smaller than, or around those expected using anticipated AUT threshold settings. If a POR analysis shall be performed, defects of vertical sizes below the rejection threshold is required.

604 As a minimum 29 defects, or ultrasonically independent parts of defects, is required for each group of defects. Ultrasonically independent parts of defect are those several beam widths apart. In order to show sufficient detection ability (90% POD) at the required confidence level (95%) the number of defects and their variation in defect types and location is referenced in tables E-2, E-3 and E-4.

605 The locations where defects were intentionally induced shall be recorded. The presence and sizes of the induced defects in the test welds shall be confirmed. For this purpose the test welds shall be subject to supplementary NDT. Supplementary NDT may encompass independent semi automatic PAUT/TOFD systems or IUT. Surface techniques are recommended. The reference point for all testing shall be the same and shall be indicated by hard stamping on the test welds. The techniques used for this testing shall be optimised for the weld geometries in question.

606 The report shall identify the identified defects from the supplementary NDT in the test welds with respect to circumferential position, length, and height. The report shall be kept confidential.

Table E-2 Number of deliberate flaws for GMAW J prep welds		
<i>Defect type group</i>	<i>No of Flaws</i>	<i>Comment</i>
Root	29 (7*)	If root channels and HP/radius channels are unique it may be possible to combine flaws from root and HP and reduce the total no in this area.
HP/radius	29 (6*)	
Fill	29 (7*)	
Cap	29 (7*)	This flaw group shall also encompass subsurface flaws with bottom part maximum 5 mm from surface
Cu	2	Cu type flaws shall not be included in PoD analyses but are included to demonstrate detection and recognition
Inter run	2 (1*)	Inter run flaws shall not be included in PoD analyses but are included to demonstrate detection and recognition
Cluster porosity	2 (1*)	Cluster porosity flaws shall be made as small as possible and then in the upper regions of the cross section. Cluster porosity shall not be included in the PoD analyses but are included to demonstrate detection and recognition.
Total Min No of Flaws	122 (29*)	Ref Root/HP comment
* Number of defects for project specific AUT procedure validation.		

Table E-3 Number of deliberate flaws for SAW X prep welds		
<i>Defect type group</i>	<i>No of Flaws</i>	<i>Comment</i>
Zone 1 D Cap	29 (9*)	Zone 1 D is encompassing the cross section from D cap to top of CP region. This group shall include surface breaking flaws and min 10 sub surface flaws with bottom part maximum 5 mm from CP/root
Zone 2 CP (root)	29 (9*)	Flaws shall be located at the cross penetration including areas where a shift in groove geometry is made. Flaws to be made on the CP, below and over CP
Zone 3 ID Cap Internal weld	29 (9*)	This zone shall include surface and sub surface flaws
Cu	2	Cu type flaws shall not be included in PoD analyses but are included to demonstrate detection and recognition
Cluster porosity	2 (2*)	Cluster porosity shall be included for demonstration and recognition only. Not be included in PoD analyses.
Total Min No of Flaws	91 (29*)	
* Number of defects for project specific AUT procedure validation.		

Table E-4 Number of deliberate flaws for SMAW/FCAW V prep welds		
<i>Defect type group</i>	<i>No of Flaws</i>	<i>Comment</i>
Root	29 (9*)	This group shall include flaws extending into HP
Fill	29 (9*)	This group assumes lack of side wall fusion or slag entrapment located on bevel/weld metal transition
Cap	29 (9*)	This flaw group shall also encompass subsurface flaws with bottom part maximum 5 mm from surface
Cu	2	Cu type flaws shall not be included in PoD analyses but are included to demonstrate detection and recognition
Slag/Inclusion weld centre line	4 (1*)	Flaws to be located at the weld centreline. Not to be included for POD analyses but for demonstration of detection and recognition.
Inter run (Only if deemed relevant for weld process)	2	Inter run flaws shall not be included in the POD analyses but are included to demonstrate detection and recognition.
Cluster porosity	2 (1*)	Cluster porosity shall be made as small as possible and then in the upper part of the cross section. Cluster porosity shall not be included in the PoD analyses, but are included to demonstrate detection and recognition.
Total Min No of Flaws	91 (29*)	
* Number of defects for project specific AUT procedure validation.		

H 700 Qualification testing

701 The testing described in the following is required for a full qualification. If validation testing is performed, the testing and documentation requirements given shall apply as applicable to the actual testing performed.

702 The test welds shall be subjected to testing by the AUT system.

For testing, a low echo amplitude recording threshold shall be used. This threshold should be selected somewhat above the noise level. PoD analysis will determine the actual detection capability and shall be expressed as the smallest detectable flaw height at 90/95% PoD at the agreed reporting threshold.

703 The reference point for circumferential positioning shall be a hard stamped on the test welds.

704 The AUT system shall be set-up, calibrated and subject to test runs before starting the formal qualification.

Repeatability testing

705 The testing shall include:

- one initial scan of the calibration block in the horizontal (5G) position
- minimum 10 scans of the calibration block(s) with the centre of the calibration block(s) in the 12 o'clock and 6 o'clock positions
- if relevant for the application of the AUT system, series of 3 consecutive scans shall be repeated with the calibration block(s) in the vertical (2G) position and/or in the 45° (6G) position.
- minimum 3 scans of a defective weld with the band offset 1 mm to the DS side
- minimum 3 scans of a defective weld with the band offset 1 mm to the US side
- The defective weld selected for the band offset scans shall include at least 6 defects, and contain at least 1 defect in each the cap, root and fill areas.

706 All scans shall be given a unique number and the documentation of the test scans shall include:

- hard copy and electronic output of all scans
- a table for repeatability test scans showing for each scan the maximum amplitude response of each transducer to its dedicated calibration reflector and the deviation for each scan from the initial calibration scan.

Temperature sensitivity testing

707 Typical test welds containing at least 6 clearly identifiable and distinct AUT indications each shall be used for scanning with the pipe axis in the horizontal position.

The test welds shall after the initial scans be heated to the elevated temperature expected during field work and maintained at this temperature during scanning. The calibration block(s) shall be kept at environmental temperature or be heated to an agreed temperature and maintained at this temperature during scanning.

The testing shall include:

- one initial scan of the calibration block
- one initial scan of the non-heated weld
- one scan of the heated test weld immediately followed by a scan of the calibration block(s)
- within 5 minutes repeat one scan of the heated test weld immediately followed by a scan of the calibration block(s). Repeat this sequence for at least 15 cycles.

If the AUT system shows unacceptable temperature sensitivity the test can be repeated with agreed different test conditions.

708 All scans shall be given a unique number and the documentation of the test scans shall include:

- hard copy and electronic output of all scans
- a table for the temperature sensitivity test scans showing the maximum amplitude response for each identified indication for each scan.

Detection ability and sizing accuracy testing

709 The test welds shall be scanned with the pipe axis horizontal. If the AUT system shall be qualified for scanning with the pipe axis vertical, the testing shall be performed in this position only or in both positions.

The scanning directions identified as clockwise or counter clockwise (CW or CCW) shall be hard stamped on the test weld. The calibration block shall be in the least favourable position as determined by the repeatability testing. See H705. The welds shall be scanned and all indications above defined thresholds shall be evaluated.

The testing shall include:

- one initial scan of the calibration block
- one scan of the test weld in the CW direction
- one scan of the calibration block(s)
- one scan of the test weld in the CCW direction
- one scan of the calibration block(s)
- assessment and sizing of indications.
- Scans performed by several teams of operators shall be present in the final data material from the reliability trials. It is recommended that the full test programme described above should be performed twice, with two independent sets of operators.

710 All scans shall be given a unique number indicating weld number, the scan sequence and the scanning direction and the documentation of the test scans shall include:

- a) hard copy and electronic output of all scans
- b) defect/indication number with reference to sizing method and for each defect/indication the dimensions:
 - circumferential position
 - length
 - height
 - depth to bottom of indication
 - transverse location of defects/indications (US, DS, C(entral))
 - maximum amplitude for each scan and variations in maximum amplitude between scans
 - main AUT zone
 - defect type.

It may further be required to report height, location, depth and echo amplitude at certain additional local defect positions (see also H603).

In addition the following information shall be provided:

- weld identification
- pipe material
- pipe thickness/diameter
- welding method
- groove geometry
- calibration block documentation.

Verification of coupling alarm settings

711 Scans shall be performed on different test welds. The couplant flow shall be reduced and the surface wiped dry between scans until the coupling alarm level/coupling monitor channels indicates loss of return signal. The level at which the coupling alarm/ coupling monitor channels indicates loss of return signal shall be recorded. The final level for coupling alarm /coupling monitor channels settings shall be at least 4 dB lower than the recorded value.

H 800 Reference destructive testing

801 The reports from the AUT qualification testing shall be validated for accuracy in the determination of defect circumferential position, length, height and depth by reference destructive testing.

802 The testing shall be by cross-sectioning, preferably by the “salami method”, by making more cross-sections around each location chosen. The defects as reported in the AUT reports shall be used when selecting the areas for cross sectioning.

In addition, locations where the AUT shows indications near the agreed reporting threshold level, locations where indications are identified by the supplementary NDT (see H605), locations where intentionally induced defects was planned but not reported and randomly chosen locations shall be included.

803 Mark-up of welds should be performed using the AUT scanner. Each position for a cross section should preferably be hard stamped close to the weld cap, consistently at the same side (US or DS) for the whole weld. Cross section indication number and clockwise scanning position should be hard stamped for each position.

804 The cross sections shall be referenced to and validated against the recording chart positions.

805 The weld sections containing defects shall be machined in increments of maximum 2.0 mm. Each machined cross section of the weld shall be polished with 800 grit and etched and the defect location, height and depth measured with accuracy better than ± 0.1 mm.

806 Each cross section shall be documented by a photograph with 5 - 10x magnification, and the photograph shall include:

- Weld number
- Specimen number
- Defect/indication number
- Circumferential position
- US and DS side of the weld
- A millimetre reference scale.

807 The extent of macro sectioning shall include:

- For determination of detection and sizing capabilities the position of a clearly defined local or total maximum height of the defect, as defined by AUT, shall be selected for “salami” cross sectioning.
- Areas where the AUT shows indications near or below the agreed reporting threshold level shall be selected for sectioning.
- Areas with single defect indications at weld bevel should be preferred as cross section positions. Stacked defects should be avoided.
- Areas of uniform defect height should be the preferred positions for cross sectioning.
- Defects from each of the main defect groups according to Tables E1-E3 (i.e. root, fill, cap, volumetric) shall be macro sectioned at ends for length sizing accuracy evaluation. Macro sectioning shall start at least 5 mm from each end of the defect as defined by AUT and the applicable recording threshold, and continue until no indication of the defect can be found at the macro.
- If the supplementary NDT indicates presence of defects not identified in the AUT reports, these areas shall also be selected for sectioning.
- Areas without any observations from supplementary NDE or AUT shall be randomly subject to sectioning. If IUT has been performed this requirement can be omitted.

H 900 Analysis

Repeatability

901 The data from the repeatability test programme shall be analysed with respect to system repeatability and stability. The maximum deviations in amplitude from each reference reflector between the initial scan and:

- the scans performed with each calibration block position
- the scans performed with the band offset
- the scans performed with removal and resetting of the band.

shall be determined.

The acceptable variation in amplitude on repeated calibration block scans is ± 2 dB. For band offset scans on defective welds, the variations in sized defect heights shall not exceed the sizing accuracy established during the qualification.

Temperature sensitivity

902 The data from the temperature sensitivity test programme shall be analysed with respect to the influence of temperature build-up in the transducers over time. The maximum variations in amplitude from each selected indication between the initial scan and the scans performed with heated test weld and with or without or heated calibration blocks shall be determined.

Based upon an acceptable variation in amplitude of ± 2 dB or in height sizing not exceeding the sizing accuracy

derived at the analysis described in paragraph H903, the analysis shall determine the:

- acceptable maximum temperature of welds
- the sum of transducer inactive time on weld and scanning time
- the minimum time between scanning of hot welds
- the maximum temperature difference between weld and calibration block.

Detection ability and sizing accuracy

903 The data recorded during the tests and reference investigations shall be analysed with respect to:

- accuracy in height sizing (random and systematic deviation, and 5% fractile)
- accuracy in length sizing
- accuracy in circumferential positioning / location
- AUT defect characterisation abilities compared to the results of the destructive tests and the other NDT performed
- as relevant, determination of PoD/PoR values or curves for different assumed echo amplitude or other employed threshold settings to determine the threshold to be used during examination.

904 The analysis shall be performed by recognised and applicable statistical methods, e.g. according to Nordtest NT Techn. Report 394 (Guidelines for NDE Reliability Determination and Description, Approved 1998-04). The omission of any reported indication in the analysis shall be justified.

H 1000 Reporting

1001 A qualification report shall as a minimum contain:

- a technical documentation of the AUT system
- outcome of the technical evaluation of the AUT system according to this Appendix
- description of the specimens and tests performed, including sensitivities used
- definitions of the essential variables (see I200) for the welds and equipment used during qualification testing
- data recorded for each defect and each defect cross-section (sizes, locations, types, measured and determined during reference investigation, echo amplitudes)
- outcome of the analysis of data (H900)
- conclusion of the qualification.

I. Project Specific AUT Procedure Validation

I 100 Scope

101 Project specific AUT procedure validation shall be performed in order to demonstrate that the project specific AUT procedure can accomplish the qualified performance capabilities. The project specific AUT validation shall normally only comprise the reliability aspects provided that all essential variables remain within reason equivalent to what has been qualified. The reliability aspect shall not include any new PoD analysis.

The validation scope shall comprise welds with at least 29 deliberately induced defects. A reduced scope of validation may be agreed for welds exposed to nominal strains $< 0.4\%$, but shall comprise at least 12 defects, including 2 observations for each group (root, fill, cap and volumetric).

A project specific AUT procedure validation shall consist of the following minimum activities:

- Review of project specific AUT procedure including any pertaining ITP, cal block design reports (WPS), AUT set up files and project specific AUT acceptance criteria including supporting ECA or fatigue reports.
- A compliance assessment of the proposed project specific AUT procedure and AUT system qualification results and pre requisites.
- Verification of hardware and software including calibration block fabrication tolerances.
- Verification of AUT set up on relevant calibration block.
- Review deliberately induced defect weld plan and verify that welds are made with relevant process and geometries.
- Perform supplementary NDT as per clause H605.
- Perform AUT inspection on deliberately induced defect welds
- Perform weld evaluation at relevant interpretation/reporting threshold, report defect height, depth and length.
- Select minimum 29 ultrasonically independent areas for macro validation testing and perform macro sectioning and reporting.

I 200 Assessment

201 The performance requirement i.e. AUT system capabilities in terms of PoD and sizing accuracy shall be verified adequate in relation to the smallest allowable weld defect permitted by either ECA/fatigue analysis

derived acceptance criteria or other quality standard description. If the AUT system performance results as concluded in the AUT system qualification are not in compliance with the project specific demands then this situation shall lead to a new qualification as per this document.

The project specific AUT procedure shall be verified against the validity range and pre requisites stated in the AUT system Qualification. Reasonable judgment shall be made to minor variations not deemed to impact on PoD and Sizing.

AUT equipment including scanner mechanics, probe/transducer arrays/types and pulser type shall be essentially equivalent as used during qualification. Software upgrades not impacting on data collection or signal processing are permitted. Changes shall be documented.

The proposed AUT set up shall be verified on the project specific calibration block. Ultrasonic responses from reflectors shall be achieved in an equivalent manner as employed during AUT system qualification.

The number of test welds containing deliberately induced defects shall be sufficient to ensure that a minimum of 29 representative defects distributed as per tables E1, E2 and E3 can be obtained. The defects shall exhibit dimensions on or close to the smallest allowable defect as per the project specific acceptance criteria.

Performance of the AUT scanning shall be conducted at ambient temperature unless otherwise agreed and at project specific reporting threshold in compliance with pre requisites given by the AUT system Qualification report. Scanning shall be performed with nominal band setting unless otherwise agreed. Reverse scanning shall be performed unless otherwise agreed. All relevant AUT indications exceeding noise level shall be reported on a suitable format containing all relevant signal information.

A minimum of 29 ultrasonically independent locations shall be selected for validation testing by macro sectioning in accordance to section 5 of this document. The selection criteria shall be as follows:

Defect indications exhibiting dimensions equivalent or larger than the AUT system PoD but smaller or equivalent to the project specific smallest allowable defect as identified in the project specific acceptance criteria adjusted for sizing accuracy.

One volumetric indication shall be included for verification.

A summary report containing all collected data shall be prepared and a comparison between supplementary NDT, AUT and macro section data shall be made. Evaluation of sizing accuracy according to clause H302 shall be performed.

The purpose of the validation is not to perform a PoD analysis but to verify that the project specific AUT procedure capability is adequate for detection of the smallest project specific critical defect. This is obtained by demonstrating detection of all 29 defects and that these 29 defects has been sized and positioned within the qualified accuracy. If this is achieved, the project specific AUT procedure is validated and shall be accepted.

J. Validity of Qualification

J 100 Validity

101 A qualification is AUT system, weld method and groove geometry specific.

Upon successful completion of the qualification scope it is assumed that the AUT system will remain qualified within the range of qualification for an infinite time period provided that the AUT system remains virtually unchanged, i.e. with no changes that are judged to have an impact on the performance parameters.

J 200 Essential variables

201 The following essential variables apply:

- welding method and groove geometry (including repair welds, if relevant)
- root and cap transducer set-up
- wall thickness (wall thickness variation requiring any change in focal law set up, adding or removing legs.
- diameter (diameter variation requiring transducer curvature which may impact on length accuracy. Systems qualified on sample larger than 12” may not be readily qualified on smaller diameter. Beam profile and effect of transducer curvature shall be determined.
- base material and welding consumables (The distinction is made on materials with substantially differences in ultrasonic response, for instance between CMn, 13% Cr, duplex or austenitic steels.)
- transducer set-up for other channels (the number of these channels may be increased or decreased to accommodate changes in wall thickness provided there are no set-up changes)
- focal laws
- reference reflectors
- working temperature range
- system, data acquisition and data treatment
- software version (except changes affecting viewing, display or bug-fixing only).

202 Changes in the essential variables for an existing qualified system will require validation trials of the modified system, in order to demonstrate validity of the qualification results. Validation trials shall be according to DNV-RP-F118.

K. Determination of Wave Velocities in Pipe Steels

K 100 General

101 The procedure defined covers methods that may be used to determine acoustic velocity of ultrasonic waves in linepipe steels. Equivalent methods may be used subject to agreement.

Linepipe used in oil and natural gas transmission exhibit varying degrees of anisotropy with varying acoustic velocities depending on the propagation direction with resultant changes in the refracted angle of the sound in the steel. This is especially critical where focused beams are used for zonal discrimination. It is thus required to determine the ultrasonic shear or longitudinal (as appropriate) wave velocity for propagation in different directions.

K 200 Equipment

201 To determine the wave velocity (shear or compression) directional dependency an ultrasonic wave transducer of the same frequency used in the inspection with a crystal diameter of 6 - 10 mm should be used in combination with an ultrasonic apparatus with bandwidth at least up to 10 MHz and a recommended capability of measuring ultrasonic pulse transit times with a resolution of 10 ns and an accuracy of ± 25 ns. Devices for measuring mechanical dimension of the specimens should have a recommended accuracy of ± 0.1 mm. As couplant an easily removable glue or special high viscosity shear or compression wave couplant (as appropriate) is recommended.

K 300 Specimens

301 A specimen is cut from a section of pipe to be tested and the corresponding results are specific for a particular pipe diameter, wall thickness and manufacturer. Specimen dimensions should be a minimum of 50 x 50 mm.

A similar arrangement can also be used for measuring velocities in a plane normal to pipe axis.

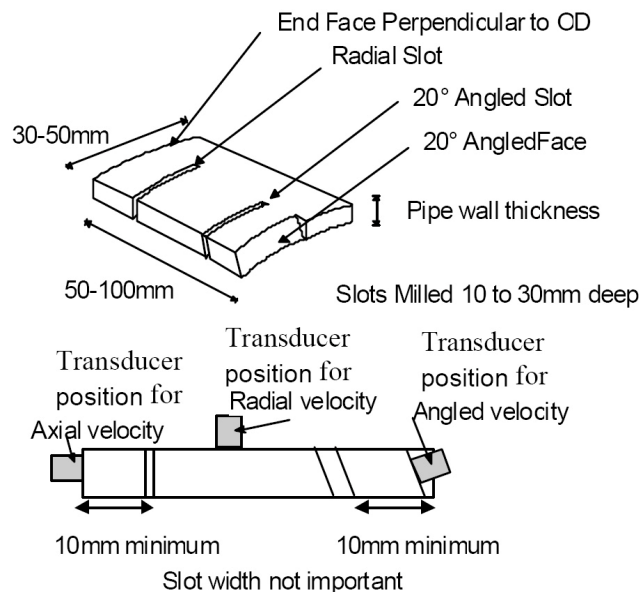

Figure 1
Test specimen and transducer placement

A minimum of three parallel surfaces are machined for the plane to be evaluated; one pair of surfaces is made in the radial direction (perpendicular to the D surface) and the other pair made 20° from the perpendicular to the D surface, see Figure 1. Additional pairs of parallel surfaces may be machined at other angles in the plane to be evaluated if more data points are desired.

The machined surfaces should be smooth to a 20 μ m finish or better. Minimum width of the specimen surface to be measured should be 20 mm and the minimum thickness between the parallel surfaces to be measured should be 10 mm. Vertical extent of the test surface will be limited by the pipe wall thickness.

K 400 Test method

401 Using the machined slots as reflectors for the wave pulses with the transducer in the appropriate positions

and measuring the pulse transit times determines together with the mechanically measured pulse travelling distances the wave velocities in the axial and 20° direction (Figure 1).

A similar measurement in the through thickness direction determines the radial velocity. Pulse transit times shall be measured between the forefront parts of 1st and 2nd back wall echo, or, alternatively, using more multiple echoes.

A minimum of three readings shall be made for each plane in which testing shall be done.

K 500 Accuracy

Errors in velocity determination shall not be greater than ± 20 m/s.

K 600 Recording

Values for the velocities determined can be tabulated and graphed. By plotting velocities on a two dimensional polar graph for a single plane, velocities at angles other than those made directly can be estimated.

The effect of temperature on velocity can be significant under extreme test conditions; therefore the temperature at which these readings have been made should also be recorded.

APPENDIX F

REQUIREMENTS FOR SHORE APPROACH AND ONSHORE SECTIONS

A. Application

A 100 Objective

101 The objective of this appendix is to provide the complementary requirements to the onshore part of the submarine pipeline system compliant with the safety philosophy for the offshore part. This appendix specifies the requirements for design, construction and operation of parts of pipeline systems going onshore.

This appendix is meant to ease the project execution of submarine pipeline developments where parts are going onshore.

Guidance note:

A submarine pipeline system is defined to end at weld beyond the first flange/valve onshore or to the pigging terminal. This implies that a, sometimes significant, part of the pipeline system can be located onshore. This part of the pipeline system may have different legislations, failure modes and failure consequences compared to the submarine part.

The exact limit of the submarine pipeline system at the onshore end may differ from this definition herein based on different statutory regulations which may govern.

Onshore codes may also take precedence of this part due to legislation aspects.

---e-n-d---of---G-u-i-d-a-n-c-e---n-o-t-e---

102 The appendix also covers requirements to shore approach.

A 200 Scope and limitation

201 The limitations found in Sec.1 A300 are in general also applicable for this Appendix.

202 The onshore section is limited by the definition of submarine pipeline system.

203 This appendix does not cover regular onshore pipelines, i.e. pipelines starting and ending onshore not having any submarine parts. River crossings or crossing of fresh water lakes are not considered as submarine sections.

Guidance note:

This appendix is not meant to replace current industry practice onshore codes or any national requirements.

---e-n-d---of---G-u-i-d-a-n-c-e---n-o-t-e---

204 Specific requirements for the onshore parts given in this appendix overrule requirements given elsewhere in the standard.

A 300 Other codes

301 This Appendix is fully aligned with the requirements given in ISO 13623

Guidance note:

ISO 13623 requires a specific utilisation for landfall. According to this code the assessment of risk will constitute selection of safety class for each specific pipeline and pipeline sections. The safety class classification for a landfall will normally give the same utilisation as required by ISO 13623 however this does not always need to be the case. This implies that the utilisation in landfall may differ from the ISO 13623 requirements and care should be taken when stating compliance with ISO 13623 for a specific pipeline development.

---e-n-d---of---G-u-i-d-a-n-c-e---n-o-t-e---

302 Onshore pipelines are normally regulated by national regulations and cover a wide range of areas from public safety, traffic and roads, water ways, environmental impact, etc. Some of these regulations may be stricter than the requirements given in this code and care shall be exercised when assuring compliance with different national regulations.

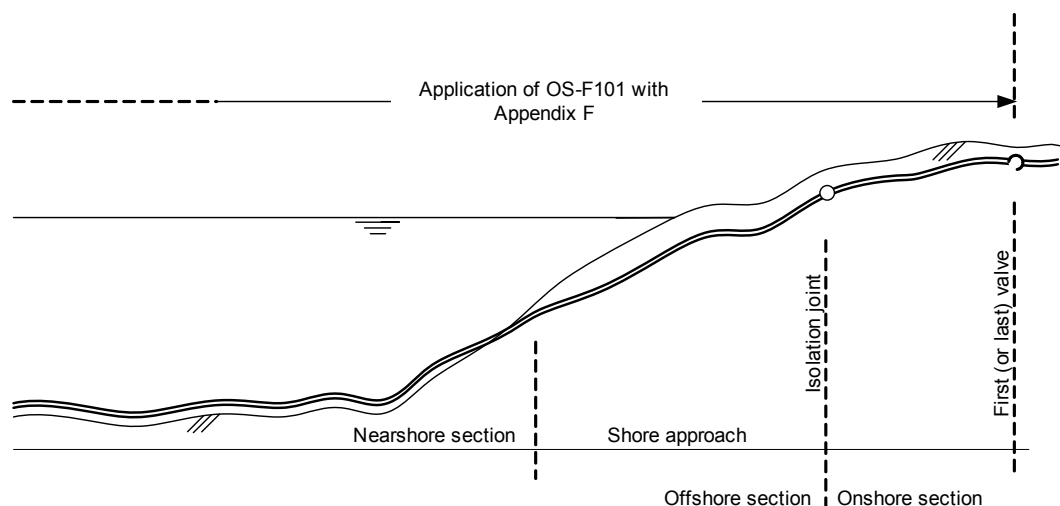

Figure 1
Maximum application extent of OS-F101 with Appendix F

A 400 Definitions

401 *Battery limit* - the limit at which the scope of work ends. The battery limit can be different for designer, installation contractor, verifier and operators. Normally defined as ‘including’ or ‘up to’ a certain weld.

402 *Code break* - the exact point at which the design code changed from submarine to onshore code. Normally defined as ‘including’ or ‘up to’ a certain weld. This is often defined at the location of the first flange or valve onshore. Note that this may differ based on different statutory regulations.

403 *First (or last) valve onshore* - valve separating the offshore and onshore pipeline. Often the position of the battery limit and the code break. Often an emergency shut down valves (ESDV)

404 *Isolation joint* - a special component separating (isolating) the offshore cathodic protection from the onshore cathodic protection system and installed within the onshore part of the offshore pipeline. It is normally positioned very close to the landfall as the offshore cathodic protecting system has limited protection capabilities when the pipeline is not submerged in water.

405 *Landfall* - where the pipeline comes on shore.

406 *Near shore* - the transition from the offshore pipeline to the shore approach area. Often not well defined, but can be the area in where the pipeline goes from laying on the sea-bed to being positioned in an open trench to where it is buried. Sometimes the extent of the areas is defined by the reach of the installation vessel or trenching equipment, and sometimes this area is given special attention by the fishing industry.

407 *Onshore part of offshore pipeline* - the first part of the pipeline on shore. It is distinct as the offshore design code is still applied, while the pipeline is not offshore. The length is normally short, up to some kilometres.

408 *Onshore pipeline* - the pipeline on shore following onshore codes and normally subject to different authority regulations

409 *Right-of-way* – corridor of land within which the pipeline operator has the right to conduct activities in accordance with the agreement with the land owner.

410 *Shore approach* - the last part of the pipeline before it comes on shore. The need for burying the pipeline in the shore approach area should be evaluated and include:

- environmental loading (breaking waves, current and tide),
- requirements to a ‘clean beach’ for recreation,
- shipping activity or
- protection (reduced access by 3rd parties).

B. Safety Philosophy

B 100 General

101 The design philosophy for the shore approach and the onshore pipeline shall comply with Sec.2. This implies that the consequences of failure (economical, environmental and human) shall be quantified by the concept of safety class. The safety class should be determined by fluid category, location class and phase (construction, operation) of the pipeline.

102 The presence of people and facilities necessitates a further refinement of the location classes used offshore. In highly populated areas the consequences may be more severe than for offshore, requiring a higher safety class, Very High.

These complementary issues are described in this sub-section.

Guidance note:

It should be noted that ISO 13623 contain even more stringent utilisation requirements than safety class Very High. However, as this code is meant to only cover onshore parts of an offshore pipeline system it is not foreseen that such a line will be located in areas with even higher population densities.

---e-n-d---of---G-u-i-d-a-n-c-e---n-o-t-e---

B 200 Safety philosophy

201 The safety philosophy outlined in Sec.2 B is applicable for shore approach and onshore sections.

Guidance note:

In particular is it important to perform a systematic review of all hazards to identify consequences as third party presence is more significant onshore.

---e-n-d---of---G-u-i-d-a-n-c-e---n-o-t-e---

202 The quality assurance outlined in Sec.2 B is applicable for shore approach and onshore sections.

203 The health, safety and environmental aspects outlined in Sec.2 B is applicable for shore approach and onshore sections also.

B 300 Quantification of consequence

301 Fluids shall be categorised in line with Sec.2 of this standard.

302 A location class shall be determined for each part of the pipeline as shown in Table F-1.

Table F-1 Location Classes Onshore	
<i>Location Class</i>	<i>Description</i>
1 (Equivalent to Location class 1 as defined in Sec.2)	Locations subject to infrequent human activity with no permanent human habitation. Location Class 1 is intended to reflect inaccessible areas such as deserts and tundra regions
2	Locations with a population density of less than 50 persons per square kilometre. Location Class 2 is intended to reflect such areas as wasteland, grazing land, farmland and other sparsely populated areas
3 (Equivalent to Location class 2 as defined in Sec.2)	Locations with a population density of 50 persons or more but less than 250 persons per square kilometre, with multiple dwelling units, with hotels or office buildings where no more than 50 persons may gather regularly and with occasional industrial buildings. Locations Class 3 is intended to reflect areas where the population density is intermediate between location Class 2 and Location Class 4, such as fringe areas around cities and towns, and ranches and country estates.
4	Locations with a population density of 250 persons or more per square kilometre, except where a Location Class 5 prevails. A Locations Class 4 is intended to reflect areas such as suburban housing developments, residential areas, industrial areas and other populated areas not meeting Location Class 5.
5	Location with areas where multi-storey buildings (four or more floors above ground level) are prevalent and where traffic is heavy or dense and where there may be numerous other utilities underground.

303 The population density in Table F-1, expressed as the number of persons per square kilometre, shall be determined by laying out zones along the pipeline route, with the pipeline in the centreline of this zone having a width of:

- 400 m for category D fluids, and
- to be determined for category E fluid pipelines, but not less than 400 m. The determination shall include the possibility of very low temperature during a leakage of high pressure pipelines, giving high density gas that may “float” significant distance prior to ignition.

304 Half the zone width shall not be less than the effective distance of fluid release.

305 The length of the zones shall be 1.5 km and located at any location along the pipeline. The length of the random sections may be reduced where physical barriers or other factors exist, which will limit the extension of the more densely populated area to a distance less than 1.5 km.

306 The possible increase in population density and level of human activity from planned future developments shall be determined and accounted for when determining population density.

307 Additional considerations shall be given to the possible consequences of a failure near a concentration of people such as found in a church, school, multiple-dwelling unit, hospital, or recreational area of an organised character in location classes 2 and 3.

308 Pipeline design according to this standard is based on potential failure consequence and is quantified by the concept of safety class. These may vary for different phases and locations and are defined in Table F-2.

<i>Safety Class</i>	<i>Description</i>
Low	Where failure implies low risk of human injury and minor environmental and economic consequences
Medium	Where failure implies risk of human injury, significant environmental pollution or very high economic or political consequences
High	Where failure during operating conditions implies high risk of human injury, significant environmental pollution or very high economic or political consequences
Very High	Where failure during operating conditions implies very high risk of human injury.

309 The acceptable failure probability of safety class Very High is one order of magnitude lower than for safety class High as given in Sec.2 of this standard.

310 The safety class determined by the crossing shall apply from:

- for road crossings
- the road right-of-way boundary
- if this boundary has not been defined, to 10 m from the edge of the hard surface of major roads and 5 m for minor roads
- for railways
- 5 m beyond the railway boundary or
- if this boundary has not been defined, to 10 m from the rail.

311 The safety class can often be determined based on the location class and fluid category. Typical selection of safety class is given in Table F-3.

<i>Phase</i>	<i>Fluid Category</i>	<i>Location Class</i>				
		<i>1</i>	<i>2</i>	<i>3</i>	<i>4</i>	<i>5²</i>
Temporary ¹	All	Low				-
Operating Onshore	A,C	Low		Medium		-
	B	Medium	Medium	High	Very High	-
	D,E	Medium	Medium	High	Very High	-
1) Installation until commissioning (temporary) will normally be classified as safety Class low. During temporary conditions after commissioning of the pipeline, special considerations shall be made to the consequences of failure, i.e. giving a higher safety class than Low.						
2) This code is not applicable for areas in location Class 5.						

C. Design Premise

C 100 General

101 The basis for design premises for the shore approach shall be as given in Sec.3. Special attention shall be given to aspects related to installation, on-bottom stability, fatigue due to direct wave loading and 3rd party activities. Statutory requirements apply.

102 The shore approach should be constructed by either

- trench,
- dredging,
- jetty,
- trussed beam support,
- horizontal directional drilled (HDD) guide tube,
- cofferdam,
- tunnel, or
- combinations of the above.

C 200 Routing

201 The requirements in Sec.3 C apply to the shore approach section. Additional requirements are given below.

202 The routing shall be selected and prepared so that risk of fire, explosions and un-intended occurrences is at an acceptable level. Spacing between pipelines, associated equipment, harbours, ship traffic and buildings shall be evaluated by risk assessments considering the service of the pipeline.

Guidance note:

The preferred means of routing for shore approach pipeline will be to bury them. Examples of additional protective means are Concrete coating or cover, additional steel wall thickness, deeper trenching, additional marking and means to minimize the possibility for impacts from ship traffic and vehicles.

---e-n-d---of---G-u-i-d-a-n-c-e---n-o-t-e---

203 Special focus shall be on:

- safety of public
- protection of environment
- 3rd party activities
- access
- other property and facilities.

204 Pipeline conveying category B, C, D and E fluids should avoid built-up areas or areas with frequent human activity.

205 In absence of public safety statutory requirements, a safety evaluation shall be performed in accordance with the general requirements for:

- Pipeline conveying category D fluids in locations where multi-storey buildings are prevalent, where traffic is heavy or dense, and where there may be numerous other utilities underground
- Pipelines conveying category E fluids.

206 An Environmental Impact Assessment (EIA) shall be performed. The EIA shall consider as a minimum:

- temporary works during construction and operation (e.g. repair, modifications etc.)
- the long-term presence of the pipeline
- leakage.

207 The route shall permit the required access and working width for the construction and operation (including any replacement), of the pipeline. The availability of utilities necessary for construction and operation should also be reviewed.

208 The route shall be tidy and free from flammable materials on and in the vicinity of the pipeline system. A safety area along the pipeline shall be defined which may restrict public access and activities. The extent of the area shall be established based on risk analyses and shown on the plan for the pipeline system.

209 Facilities along the pipeline route should be identified and their impact evaluated in consultation with the operator of these facilities. Facilities should not be allowed closer than 4 m from the pipeline.

210 A wider restriction zone compared to public access may apply to future development (buildings etc.).

C 300 Environmental data

301 Environmental data shall be collected as described in Sec.3. Long term shore profile shall be considered. Special attention shall be given to tidal variations.

C 400 Survey

401 Route and soil surveys shall be carried out to identify and locate with sufficient accuracy the relevant geographical, geological, geotechnical, corrosive, topographical and environmental features, and other facilities such as other pipelines, cables and obstructions, which may impact the pipeline route selection. The surveys shall be continuous, and the accuracy and tolerance should be selected with regard to the adjoining land and offshore surveys.

402 Inshore survey coverage should be continuous and in agreement within specified tolerances and accuracies of both adjoining land and offshore route surveys.

C 500 Marking

501 The pipeline system shall be marked in such a way that its location in the terrain is clearly visible. Provisions shall be made to restrict public access to pipelines that are not buried.

502 Warning signs shall be placed within visible distance and at each side of crossings with rivers, roads and rail ways giving information on:

- content
- operator
- phone number to nearest manned station which may be alerted in the event of fault on the pipeline.

D. Design

D 100 General

101 The pigging requirements in Sec.3 D102 applies to the pipeline system.

D 200 System design

201 Any electrical equipment within the location class areas shall comply with the location class requirements.

202 The need for lightening rod and means to avoid build up of static electricity shall be considered.

203 Branch connections for pipelines on land shall be supported by consolidated backfill or provided with adequate flexibility.

204 Braces and damping devices required to prevent vibration of piping shall be attached to the pipe by full encirclement members.

205 For structural items, doubler plates and rings welded directly to pressure containing parts, the following apply:

- Design shall be performed for all relevant failure modes, e.g. yielding, fatigue and fracture.
- For duplex stainless steels and 13Cr martensitic stainless steels a stress analysis shall be performed in each case to determine that local stresses will not initiate HISC. Recommended practice for design of duplex stainless steels is given in DNV-RP-F112.
- Welding directly to the pressure containing parts shall be performed in accordance with qualified welding procedures according to Appendix C.
- NDT shall be performed to ensure structural integrity of the pressure containing parts.
- The toe-to-toe distance from other welds shall be minimum $2 \cdot t$ or 50 mm, whichever is larger.

206 For doubler plates or rings the following apply:

- Design shall be performed for all relevant failure modes.
- Doubler plates should be circular.
- Welds shall be performed in accordance with qualified welding procedures.
- Doubler rings shall be made as fully encircling sleeves with the longitudinal welds made with backing strips, and avoiding penetration into the main pipe material.
- Other welds shall be continuous, and made in a manner minimising the risk of root cracking and lamellar tearing.

D 300 Design loads

301 The loads shall be established as described in Sec.4. Special attention shall be given calculations of loads from 3rd party activities such as traffic (potential cyclic loading) and other construction work.

302 The loads shall be classified into functional, environmental, interference or accidental loads as per Sec.4 of this standard with the additional requirements below.

303 Traffic axle loads and frequency shall be established in consultation with the appropriate authorities or other relevant sources and with recognition of existing and forecast residential, commercial and industrial developments.

D 400 Design criteria

401 The design should comply with the requirements in Sec.5. Special attention shall be given to statutory requirements.

402 For safety class Very High the safety class factors in Table F-4 apply.

Table F-4 Partial safety class resistance factor for safety class Very High	
<i>Limit state</i>	γ_{SC}
Pressure containment	1.593
Other limit states	1.5

403 Buried pipelines on land should be installed with a cover depth not less than shown in Table F-5.

Table F-5 Minimum cover depth for buried pipelines on land (alternative, preferred formulation to the table above)		
Safety Class ³⁾	Cover depth [m] ^{1) 2) 4) 5) 6) 7)}	
	Trench blasted in rock	Other
Low	0.5	0.8
Medium		0.8
High		1.2
Very High		1.2
1) Cover depth shall be measured from the lowest possible ground surface level to the top of the pipe, including coatings and attachments. 2) Special consideration for cover may be required in areas with frost heave. 3) River crossings, road crossings and railway crossing shall in this context be classified as safety class High. 4) Cover shall not be less than the depth of normal cultivation +0.3 m. 5) For river crossings; to be measured from the lowest anticipated bed. 6) For roads and railway crossings; to be measured from the bottom of the drain ditches 7) The top of pipe shall be at least 0.15 m below the surface of the rock.		

404 The effect of cover depth shall be considered in the expansion evaluations.

405 If the pipeline is not laid at a frost free depth, the mass below the pipe's centre line must be frost proof.

406 Pipelines may be installed with less cover depth than indicated in Table F-5, provided a similar level of protection is provided by alternative methods. The design of alternative protection methods should take into account:

- any hindrance caused to other users of the area
- soil stability and settlement
- pipe stability cathodic protection
- pipeline expansion
- access for maintenance.

407 Pipelines running parallel to a road or railway should be routed outside the corresponding right-of-way.

408 The vertical separation between the top of the pipe and the top of the rail should be a minimum of 1.4 m for open-cut crossings and 1.8 m for bored or tunnelled crossings.

409 Protection requirements for pipeline crossings of canals, rivers and lakes should be designed in consultation with local water and waterways authorities.

410 Crossings of flood defences can require additional design measures for prevention of flooding and limiting the possible consequences.

411 Crossing pipelines and cables should be kept separated by a minimum vertical distance of 0.3 m.

412 Pipeline bridges may be considered when buried crossings are not practicable. Pipe bridges shall be designed in accordance with structural design standards, with sufficient clearance to avoid possible damage from the movement of traffic, and with access for maintenance. Interference between the cathodic protection of the pipelines and the supporting bridge structure shall be considered.

413 Provisions shall be made to restrict public access to pipe bridges.

414 If other criteria are used, the nominal failure probabilities shall be demonstrated to be as specified in Sec.2.

E. Construction

E 100 General

101 The same requirements as for the Offshore part of the pipeline system shall be applied to the onshore part, if applicable. Where this is not applicable, the requirements of ISO 13623 should be complied with.

E 200 Linepipe

201 The manufacture of linepipe should comply with the requirements in Sec.6.

E 300 Components and assemblies

301 The requirements to components and structural items as well as assemblies should comply with Sec.7.

E 400 Corrosion protection and coatings

401 The corrosion protection shall comply with Sec.8.

402 All metal pipelines should be provided with an external coating and, for buried or submerged sections, cathodic protection. Corrosion protection should be provided by impressed current.

403 The design of the impressed current protection system shall strive for a uniform current distribution along the pipelines and shall define the permanent location for the measurement of the protection potentials.

404 Protected pipelines should be electrically isolated from other structures, such as compressor stations and terminals, by suitable in-line isolation components.

405 Isolation joints should be provided with protective devices to prevent damage from lightning or high-voltage earth current where possible. Low-resistance grounding to other buried metallic structures shall be avoided. Electrical continuity shall be provided across components, other than couplings/flanges, which would otherwise increase the longitudinal resistance of the pipeline. Spark gaps shall be installed between protected pipelines and lightning protection systems.

406 Test points for the routine monitoring and testing of the cathodic protection should be installed at the following locations:

- crossings with DC traction systems
- road, rail and river crossings and large embankments
- sections installed in sleeve pipes or casings
- isolated couplings
- where the pipeline runs parallel to high-voltage cables
- sheet piles
- crossings with other major metallic structures with, or without, cathodic protection.

407 The primary corrosion control for internal corrosion is identical with the submarine part, see Sec.8.

F. Operation

F 100 General

101 The requirements to safe and reliable operation of the pipeline systems and the pipeline integrity management (PIM) as described in Sec.11 apply.

102 The whole route shall regularly be checked for:

- any required re-classification of location class due to changes in premises like populations etc.
- new facilities
- new intruders or changed configurations that may cause increase risk of threats.

G. Documentation

G 100 General

101 In addition to the requirements in Sec.12, the following apply:

- crossing locations related to lakes, straits, rivers, streams, transport communication arteries and similar
- maps necessary to evaluate the proposed route classification
- relevant drawings on bridges etc.
- maps with any crossing services (cables, sewage etc.).